

NAVAL SHIPS' TECHNICAL MANUAL

CHAPTER 594

SALVAGE - SUBMARINE SAFETY ESCAPE AND RESCUE DEVICES

THIS CHAPTER SUPERSEDES CHAPTER 594 DATED 1 AUGUST 1981

DISTRIBUTION STATEMENT C: DISTRIBUTION AUTHORIZED TO U.S. GOVERNMENT AGENCIES AND THEIR CONTRACTORS; ADMINISTRATIVE OPERATIONAL USE (1 AUGUST 1981). OTHER REQUESTS FOR THIS DOCUMENT WILL BE REFERRED TO THE NAVAL SEA SYSTEMS COMMAND (SEA-56Z11).

DESTRUCTION NOTICE: DESTROY BY ANY METHOD THAT WILL PREVENT DISCLOSURE OF CONTENTS OR RECONSTRUCTION OF THE DOCUMENT.

PUBLISHED BY DIRECTION OF COMMANDER, NAVAL SEA SYSTEMS COMMAND.

31 JAN 1995

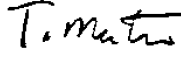
NAVSEA TECHNICAL MANUAL CERTIFICATION SHEET						_ 1 _ of _ 1 _	
Certification Applies to: New Manual <input type="checkbox"/>						Revision <input checked="" type="checkbox"/>	Change <input type="checkbox"/>
Applicable TMINS/Pub. No. <u>S9086-T9-STM-010/CH-594R1</u>							
Publication Date (Mo, Da, Yr) <u>January 31, 1995</u>							
Title: <u>NSTM Chapter 594, Salvage - Submarine Safety Escape and Rescue Devices</u>							
TMCR/TMSR/Specification No: <u>T0005-AC-CGY-010, MIL-M-28001A, MIL-M-28002,</u>							
MIL-STD-1840A, MIL-M-38784C							
CHANGES AND REVISIONS:							
Purpose: <u>Naval Ships' Technical Manual (NSTM) Chapter 594 of August 1, 1981</u>							
<u>is superseded by Chapter 594 of January 31, 1995. This revision results from Naval Sea Systems</u>							
<u>Command's program to revise, repackage, and reissue the NSTM.</u>							
Equipment Alteration Numbers Incorporated: <u>N/A</u>							
TMDER/ACN Numbers Incorporated: <u>R-18006, R-25767</u>							
<i>Continue on reverse side or add pages as needed.</i>							
CERTIFICATION STATEMENT							
This is to certify that responsible NAVSEA activities have reviewed the above identified document for acquisition compliance, technical coverage, and printing quality. This form is for internal NAVSEA management use only, and does not imply contractual approval or acceptance of the technical manual by the Government, nor relieve the contractor of any responsibility for delivering the technical manual in accordance with the contract requirement.							
Authority	Name	Signature	Organization	Code	Date		
Acquisition	Paul B. Crabb		NAVSEA	03W1	2/6/95		
Technical	T. Merten		NAVSEA	03W14	2/6/95		
Printing Release	Digital Media Publishing		Naval Surface Warfare Center	5H31			

Certification Sheet

TABLE OF CONTENTS

Chapter/Paragraph	Page
594 SALVAGE - SUBMARINE SAFETY: ESCAPE AND RESCUE DEVICES . . .	594-1
SECTION 1. SUBMARINE ABANDONMENT	594-1
594-1.1 CAUSES OF SUBMARINE ABANDONMENT	594-1
594-1.1.1 DESCRIPTION.	594-1
594-1.2 FACTORS INFLUENCING SUBMARINE ABANDONMENT	594-1
594-1.2.1 GENERAL.	594-1
594-1.2.2 RESCUE AND ESCAPE OPERATIONS.	594-1
594-1.2.3 RESCUE SYSTEM DEPLOYMENT.	594-2
594-1.2.4 CRITERIA FOR ESCAPE OR RESCUE.	594-3
594-1.2.4.1 Criteria Supporting the Decision to Escape.	594-4
594-1.2.4.2 Criteria Supporting the Decision to Await Rescue.	594-5
594-1.2.5 COMMUNICATING THE SUBMARINE’S LOCATION.	594-5
594-1.2.6 COMMUNICATING THE SUBMARINE’S CONDITION.	594-5
SECTION 2. COLLECTIVE RESCUE USING SUBMARINE RESCUE CHAMBER	594-6
594-2.1 SUBMARINE RESCUE CHAMBER (SRC)	594-6
594-2.1.1 GENERAL IDENTIFICATION.	594-6
594-2.1.2 DESCRIPTION.	594-6
594-2.1.3 EXTERIOR FEATURES.	594-7
594-2.1.4 UPPER COMPARTMENT.	594-7
594-2.1.4.1 Air Motor.	594-7
594-2.1.4.2 Ballast.	594-8
594-2.1.4.3 Instrumentation.	594-8
594-2.1.4.4 Electrical Equipment.	594-8
594-2.1.4.5 Communication Equipment.	594-8
594-2.1.4.6 Viewports.	594-8
594-2.1.5 LOWER COMPARTMENT.	594-8
594-2.1.5.1 Downhaul Equipment.	594-8
594-2.1.5.2 Hold-Down Devices.	594-9
594-2.1.6 BALLAST TANK.	594-10
594-2.1.7 PIPING SYSTEMS.	594-10
594-2.1.7.1 Air System.	594-10
594-2.1.7.2 Flood and Drain System.	594-10
594-2.1.7.3 Spill and Vent System.	594-10
594-2.1.7.4 Hydraulic System.	594-10
594-2.1.7.5 Emergency Breathing System.	594-10
594-2.1.7.6 Exhaust and Vent System.	594-10
594-2.1.8 MISCELLANEOUS EQUIPMENT.	594-10
594-2.1.8.1 Hoses.	594-10
594-2.1.8.2 Communication Cable.	594-10
594-2.1.8.3 Backhaul Line.	594-11

TABLE OF CONTENTS - Continued

Chapter/Paragraph	Page
594-2.1.8.4 Lifting Pendant.	594-11
594-2.1.8.5 Miscellaneous Tool Bag.	594-11
594-2.1.8.6 Battle Lanterns.	594-11
594-2.1.8.7 Lower Hatch Lifting Tackle.	594-11
594-2.1.8.8 Protective Headgear.	594-11
594-2.2 SRC RESCUE OPERATIONS	594-11
594-2.2.1 GENERAL.	594-11
SECTION 3. COLLECTIVE RESCUE USING DEEP SUBMERGENCE	
RESCUE VEHICLE	594-13
594-3.1 DEEP SUBMERGENCE RESCUE VEHICLE (DSRV)	594-13
594-3.1.1 GENERAL.	594-13
594-3.1.2 DESCRIPTION.	594-13
594-3.1.3 DSRV SKIRT.	594-14
594-3.1.4 DSRV PROPULSION AND CONTROL.	594-14
594-3.2 DSRV RESCUE OPERATIONS	594-14
594-3.2.1 GENERAL.	594-14
SECTION 4. INDIVIDUAL ESCAPE USING THE RESCUE/ESCAPE TRUNK	594-16
594-4.1 INDIVIDUAL ESCAPE	594-16
594-4.1.1 DEFINITION.	594-16
594-4.1.2 METHOD.	594-16
594-4.2 SUBMARINE ESCAPE APPLIANCE	594-17
594-4.2.1 GENERAL.	594-17
594-4.2.2 DESCRIPTION.	594-17
594-4.2.2.1 Buoyancy Chamber.	594-20
594-4.2.2.2 Breathing Hood.	594-20
594-4.2.2.3 Neck Ring.	594-20
594-4.2.2.4 Oral Inflation Device.	594-20
594-4.2.2.5 Snorkel Valve and Mouthpiece.	594-20
594-4.2.2.6 Charging Adapter and Check Valve.	594-20
594-4.2.2.7 Buoyancy Chamber Pressure Relief Valves.	594-20
594-4.2.2.8 Breathing Hood Pressure Relief Valves.	594-20
594-4.2.2.9 Zipper.	594-20
594-4.2.2.10 Accessory Pocket with Whistle, Sea-Dye Marker, and Nose Clip.	594-21
594-4.2.2.11 Belt.	594-21
594-4.2.2.12 Toggle Line.	594-21
594-4.2.2.13 Preserver Stowage Pouch.	594-21
594-4.2.2.14 Personnel Marker Light.	594-21
594-4.2.2.15 Reflective Tape.	594-21
594-4.2.3 DONNING AND ADJUSTING.	594-22

TABLE OF CONTENTS - Continued

Chapter/Paragraph	Page	
594-4.2.4	MAINTENANCE.	594-23
594-4.2.5	STOWAGE.	594-23
594-4.2.6	PLASTIC FACE SHIELD REPAIR.	594-24
594-4.3	SUBMARINE RESCUE/ESCAPE TRUNK	594-24
594-4.3.1	DESCRIPTION.	594-24
594-4.3.2	FEATURES.	594-27
594-4.3.2.1	Hatches.	594-27
594-4.3.2.2	Portable Bubble Skirt.	594-27
594-4.3.2.3	Flooding System.	594-27
594-4.3.2.4	Blow and Vent System.	594-28
594-4.3.2.5	Air Charging System.	594-28
594-4.3.2.6	Trunk Drain System.	594-28
594-4.3.2.7	Upper Hatch Cavity Drain System.	594-28
594-4.3.2.8	Overhead Light.	594-28
594-4.3.2.9	Portable Hand Lanterns.	594-28
594-4.3.2.10	Loudspeaker.	594-28
594-4.3.2.11	Hammer Signal Code Plate.	594-28
594-4.3.2.12	Allowable Bottom Time Chart.	594-29
594-4.3.2.13	Hammer.	594-29
594-4.3.2.14	Valve Persuader.	594-29
594-4.3.2.15	Diver's Knife.	594-29
594-4.3.2.16	Mechanical Timer.	594-29
594-4.3.2.17	Steinke Hood Operating Procedure Plate.	594-29
594-4.4	INDIVIDUAL ESCAPE PROCEDURE	594-29
594-4.4.1	GENERAL.	594-29
594-4.4.2	PHYSIOLOGICAL EFFECTS DURING INDIVIDUAL ESCAPE.	594-29
594-4.4.2.1	Effects of Increased Pressure on the Body.	594-29
594-4.4.2.2	Effects of Rapid Pressurization on the Ears.	594-30
594-4.4.2.3	Effects of Increased Concentrations of Carbon Dioxide in the Atmosphere.	594-30
594-4.4.2.4	Effects of Increased Concentrations of Nitrogen on the Body.	594-30
594-4.4.3	GENERAL STEPS TAKEN WHEN PREPARING TO ESCAPE.	594-30
594-4.4.4	GENERAL PROCEDURE FOR BUOYANT FREE-BREATHING METHOD OF SUBMARINE ESCAPE.	594-31
SECTION 5.	SUBMARINE ESCAPE TRAINING	594-33
594-5.1	SUBMARINE SCHOOL	594-33
594-5.1.1	GENERAL.	594-33
594-5.2	ONBOARD SUBMARINE TRAINING	594-34
594-5.2.1	GENERAL.	594-34

LIST OF TABLES

Table	Title	Page
594-2-1	STANDARD SRC-DISSUB TAP SIGNALS	594-12
594-3-1	STANDARD DSRV-DISSUB TAP SIGNALS	594-16

LIST OF ILLUSTRATIONS

Figure	Title	Page
	Certification Sheet	0-2
594-1-1	Submarine Escape Depth and Probability of Developing DCS	594-2
594-1-2	Factors Affecting the Decision to Await Rescue or to Escape from a DISSUB	594-4
594-2-1	Submarine Rescue Chamber	594-7
594-2-2	Features of Typical Rescue/Escape Trunk with 30-Inch Upper Access Hatch	594-9
594-3-1	Deep Submergence Rescue Vehicle (DSRV)	594-14
594-3-2	Typical Sequence of Events During DSRV Rescue Operation	594-15
594-4-1	Submarine Escape Appliance	594-17
594-4-2	Detail View of Submarine Escape Appliance Features (Reflective Tape Not Shown)	594-19
594-4-3	Reflective Tape Applied to Submarine Escape Appliance	594-22
594-4-4	Typical Rescue/Escape Trunk on SSN 637 and Earlier Classes	594-25
594-4-5	Typical Rescue/Escape Trunk with Portable Skirt on SSN 688 and Later Classes	594-26
594-4-6	Typical Rescue/Escape Trunk Features	

CHAPTER 594

SALVAGE - SUBMARINE SAFETY: ESCAPE AND RESCUE DEVICES

SECTION 1.

SUBMARINE ABANDONMENT

594-1.1 CAUSES OF SUBMARINE ABANDONMENT

594-1.1.1 DESCRIPTION. Damage to a submarine resulting from an explosion, collision, material failure, or other event could lead to conditions that require abandoning the submarine while it is submerged. Whatever the cause, extensive flooding of major compartments may prevent the submarine from surfacing under its own power. Under such conditions, procedures for immediate rescue or escape must be initiated. If rescue or escape is delayed, depleted oxygen levels in the submarine's atmosphere and rising carbon dioxide levels can ultimately lead to the death of the crew.

594-1.2 FACTORS INFLUENCING SUBMARINE ABANDONMENT

594-1.2.1 GENERAL. Most submarines have been fitted with at least two rescue/escape trunks, one for each main compartment. SSBN 726 class (TRIDENT) submarines have three rescue/escape trunks. These trunks typically have all the features (see [Section 5](#)) necessary for either two-man escape evolutions using submarine escape appliances (Steinke hoods) or collective (group) rescues by a Deep Submergence Rescue Vehicle (DSRV) or a Submarine Rescue Chamber (SRC). The exterior hull structure around the upper access hatch of the rescue/escape trunks incorporates a strengthened, flat, machined seating surface (rescue seat) to allow for proper mating of a DSRV or SRC. For more information on the capabilities of and the requirements for using the DSRV or SRC rescue systems, see NAVSEA S9594-AE-GTP-010, **Disabled Submarine Requirements for Employment of U.S. Navy Submarine Rescue Systems** .

594-1.2.2 RESCUE AND ESCAPE OPERATIONS. Listed below are general factors that influence how and when rescue and escape operations should be performed and how successful they will be. These factors have to be considered before deciding whether to abandon the submarine by using the rescue/escape trunks for individual escapes or to wait for collective rescue by a DSRV or SRC. Collective rescue by a DSRV or SRC is much safer than individual escape and in most cases is the preferred method of submarine abandonment.

1. Time required for search and rescue forces to locate the disabled submarine (DISSUB). Survival time aboard the DISSUB is limited. Early location of the DISSUB provides more time for the crew to assess the situation and decide whether to await rescue or start escape operations.
2. Availability of a DSRV or SRC and its associated surface support. Surface support is essential in order to safely and successfully conduct any submarine rescue operation. Depending on the location of the DISSUB and the rate at which conditions in it are deteriorating, a DSRV or SRC might be unable to reach the accident site before individual escape operations would have to begin.
3. Depth of the DISSUB. Safe and successful escape operations using the submarine escape appliance are limited by the depth of the DISSUB.
4. Pitch and roll angle of the submarine. The DSRV and SRC can only mate with the DISSUB within set pitch and roll limits.

5. Current across the submarine's hull. The DSRV and SRC can only mate with the DISSUB within certain current limits.
6. Internal pressure of the submarine. Pressurization of the DISSUB's atmosphere affects the ability of the DSRV and SRC to mate with the DISSUB. Pressurization of the DISSUB's atmosphere also increases the risk that survivors will develop decompression sickness (DCS) upon returning to the surface (see [Figure 594-1-1](#)).
7. Temperature of the surrounding water. The temperature of the water and the temperature on the surface will affect the length of time that personnel, after escaping the DISSUB, can remain unprotected in the water before developing hypothermia.
8. Weather conditions on the surface. Surface support capability, rescue operations, and the safe recovery of escapees are affected by the weather conditions on the surface.
9. Condition of the submarine's internal atmosphere. The concentrations of carbon dioxide, oxygen, and toxic gases are major concerns that will influence the decision to escape or await rescue.
10. Extent of damage to the submarine. Flooding, fire, and extent of structural damage are key factors that will influence the decision to escape or await rescue.

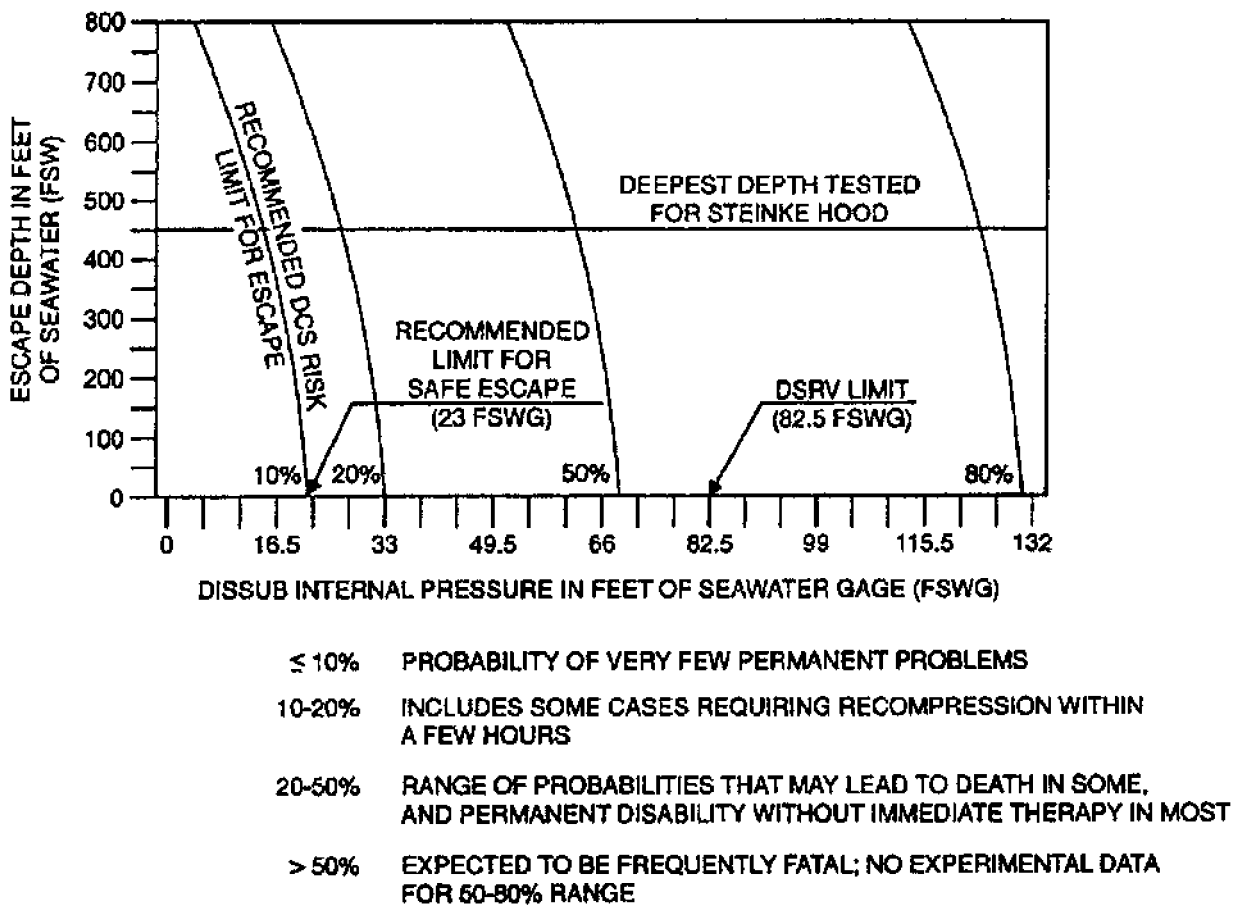

Figure 594-1-1 Submarine Escape Depth and Probability of Developing DCS

594-1.2.3 RESCUE SYSTEM DEPLOYMENT. The following general factors should be taken into account by the onsite Rescue Mission Commander when deciding which rescue system (DSRV or SRC) to deploy:

1. Location of the DISSUB.
2. Availability of a DSRV, SRC, and support ships.
3. Pitch and roll angle of the DISSUB.
4. Current across the DISSUB's hull.
5. Weather conditions on the surface.

594-1.2.4 CRITERIA FOR ESCAPE OR RESCUE. Rescue, whenever feasible, is always preferred over escape from a medical and physiological point of view. There are conditions, however that require individuals to escape using Steinke hoods. Multiple factors must be considered when making the decision whether to escape or wait for rescue (see [Figure 594-1-2](#)). Of all these factors the greatest consideration should be given to the atmospheric conditions in the DISSUB, particularly the levels of carbon dioxide and oxygen in the air; the rate at which these levels are changing; and the DISSUB's internal pressure.

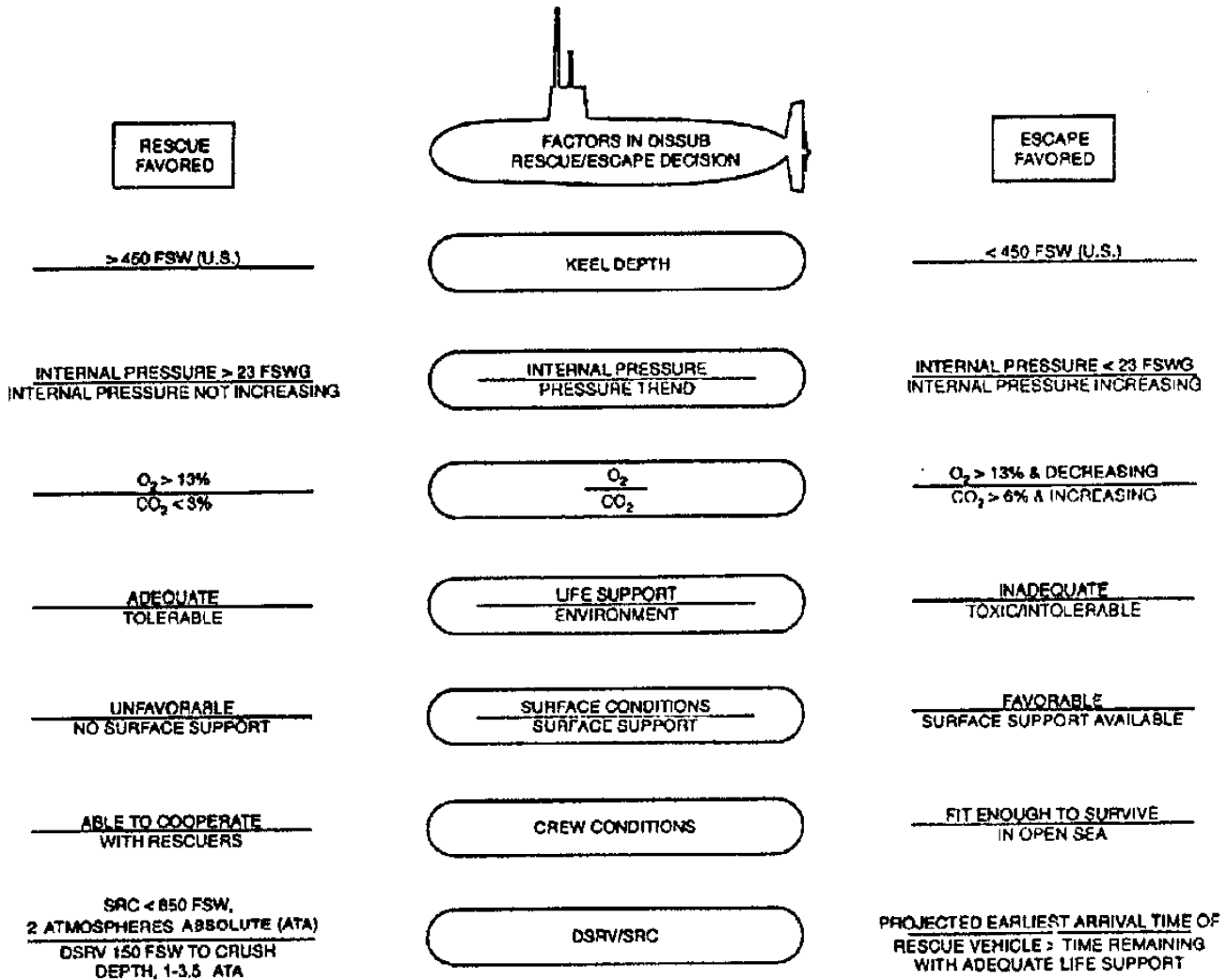

Figure 594-1-2 Factors Affecting the Decision to Await Rescue or to Escape from a DISSUB

594-1.2.4.1 Criteria Supporting the Decision to Escape. Escape should be considered if one or more of the following criteria are met:

1. Uncontrolled flooding or fire exists.
2. The carbon dioxide concentration is approaching 6 percent and is continuing to increase after all means to control carbon dioxide buildup have been used. Waiting until the carbon dioxide levels are intolerable will give survivors only a few extra hours to safely remain on board the DISSUB and will greatly complicate the escape sequence as the survivors' mental capacities deteriorate.
3. The oxygen concentration is approaching 13 percent and is decreasing after using all onboard reserves.
4. The internal atmospheric pressure of the DISSUB is increasing and rescue is not immediately anticipated. Escape should be made before the internal pressure reaches 23 feet of seawater gage (fswg) or 1.7 atmospheres

to minimize the risk of DCS in survivors when they reach the surface. The DISSUB crew should use [Figure 594-1-1](#) to determine when escape should begin based on the internal atmospheric pressure and the depth at which the rescue/escape trunk operations are to be conducted.

5. Persistent toxic atmosphere requires the use of emergency air breathing masks.
6. Surface support is present to retrieve and care for survivors, especially in colder waters.
7. Rescue/escape trunk operations are conducted at a depth of 450 feet of seawater (fsw) or less. Successful escapes from greater depths are possible but are riskier.
8. The crew's physical condition will allow them to survive in the open ocean until rescue personnel arrive.

594-1.2.4.2 Criteria Supporting the Decision to Await Rescue. The decision to await rescue should be considered if the following criteria are met:

1. Rescue assets are expected to arrive before conditions requiring escape develop.
2. Oxygen concentration is greater than 13 percent and carbon dioxide concentration is 3 percent or less and not rapidly increasing.
3. Internal atmospheric pressure exceeds 23 fswg (1.7 atmospheres) and is not increasing.
4. Life support supplies such as carbon dioxide absorbent (lithium hydroxide) and oxygen are adequate to maintain a breathable atmosphere until rescue.
5. Escape trunk operations would occur at a depth greater than 450 fsw.
6. There is no surface support for survivors and surface conditions are unfavorable (high winds, high sea state, or cold).
7. The crew is not physically fit or equipped to survive in the open sea for a long time.

594-1.2.5 COMMUNICATING THE SUBMARINE'S LOCATION. The submarine's crew should use all available means to broadcast the status of the DISSUB. This will help locate the submarine and aid in making an early decision about the rescue method to be used. The ship's communication system or emergency communication transmitters can be used to signal that the submarine is disabled. Search and rescue ships can detect signals from various sources on the submarine, including active sonar equipment, underwater telephone, emergency underwater telephone, remote acoustic communication system (RACS), or the crew hammering on the hull. Search sonar on surface ships and side look sonar towed by surface ships can be used to locate the submarine. Flares, buoys, or debris ejected from the submarine that can be seen on the surface by aircraft or surface ships can also indicate its location. During actual rescue operations, the AN/BQN-13 submarine distress pingers are the primary means of broadcasting the location of the DISSUB to search and rescue parties and guiding a DSRV to the submarine.

594-1.2.6 COMMUNICATING THE SUBMARINE'S CONDITION. Informing rescue personnel of the condition of the DISSUB is vital. Knowledge of conditions in the submarine will aid rescue personnel in determining what rescue methods to use and how to protect themselves during actual rescue operations. This information has also helped crews in the past during their escapes and is useful to salvage personnel during salvage operations. The following information should be recorded and transmitted to rescue personnel:

1. Location and extent of damage to the pressure hull, main ballast tanks, hull appendages, internal equipment, and ship systems.

2. Location and extent of flooding and the amount of nonflooded volume.
3. Condition of the atmosphere with regard to internal pressure, carbon dioxide and oxygen levels, presence of contamination, etc.
4. Available services and equipment.
5. Availability of supplies such as carbon dioxide absorbent (lithium hydroxide), medical supplies, food, drinking water, etc.
6. Ship's depth, pitch angle, roll angle, and true heading.
7. Number and general condition of survivors, including the extent of injuries.
8. Internal air temperature and temperature of seawater at DISSUB depth.
9. Number of Steinke hoods available.
10. Availability of air banks and current bank pressures, oxygen banks and current bank pressures, and atmospheric monitoring equipment.

SECTION 2.

COLLECTIVE RESCUE USING SUBMARINE RESCUE CHAMBER

594-2.1 SUBMARINE RESCUE CHAMBER (SRC)

594-2.1.1 GENERAL IDENTIFICATION. SRC's are assigned to Commander Submarine Development Squadron Five as a primary part of the Submarine Rescue Fly-Away Kit. An SRC can be deployed on any available ship with a crane capable of launching and recovering the SRC. The SRC's rated depth is 259 meters (850 feet) with a test depth (no personnel on board) of 387 meters (1270 feet). The Submarine Rescue Fly-Away Kit is configured for aircraft load out and transportation to the nearest port facility. It contains all the equipment required to lay a four-point moor and to support the SRC to a depth of 259 meters (850 feet). Under favorable conditions, the SRC can make a seal on a submarine that is inclined to angles up to 30 degrees from vertical in either the fore and aft or athwartship's direction.

594-2.1.2 DESCRIPTION. The SRC design is based on the McCann chamber. The SRC is a cylindrical steel structure with an elliptical head (see [Figure 594-2-1](#)). The SRC measures about 3.5 meters (11-1/2 feet) high and weighs approximately 9.52 metric tons (21,000 pounds). The outside diameter near the top measures 2.1 meters (84 inches) and tapers to 1.5 meters (60 inches) at the bottom. The SRC is divided into three sections: an upper compartment, a lower compartment, and a ballast tank. The upper compartment houses all operating equipment and controls, the operators, and rescued personnel. The lower compartment is open to ambient sea pressure except when seated on and sealed over a submarine rescue/escape hatch. On the bottom of the lower compartment is the SRC-to-disabled submarine (DISSUB) mating surface, which consists of a strengthened seating surface that has a machined dovetailed groove for a rubber sealing gasket. This rubber gasket is held in place by a stainless steel retaining ring. The SRC is supported by a surface ship during all operations. Air, electrical power, and communications are provided to the SRC through an umbilical between the support ship and the SRC. For a detailed description of the SRC, detailed operating procedures, and maintenance instructions, refer to NAVSEA SS750-AA-MMA-010/850 FT, **Technical Manual for Modernized 850 Foot Submarine Rescue Chambers**. The following sections briefly discuss some of the various features and systems of the SRC.

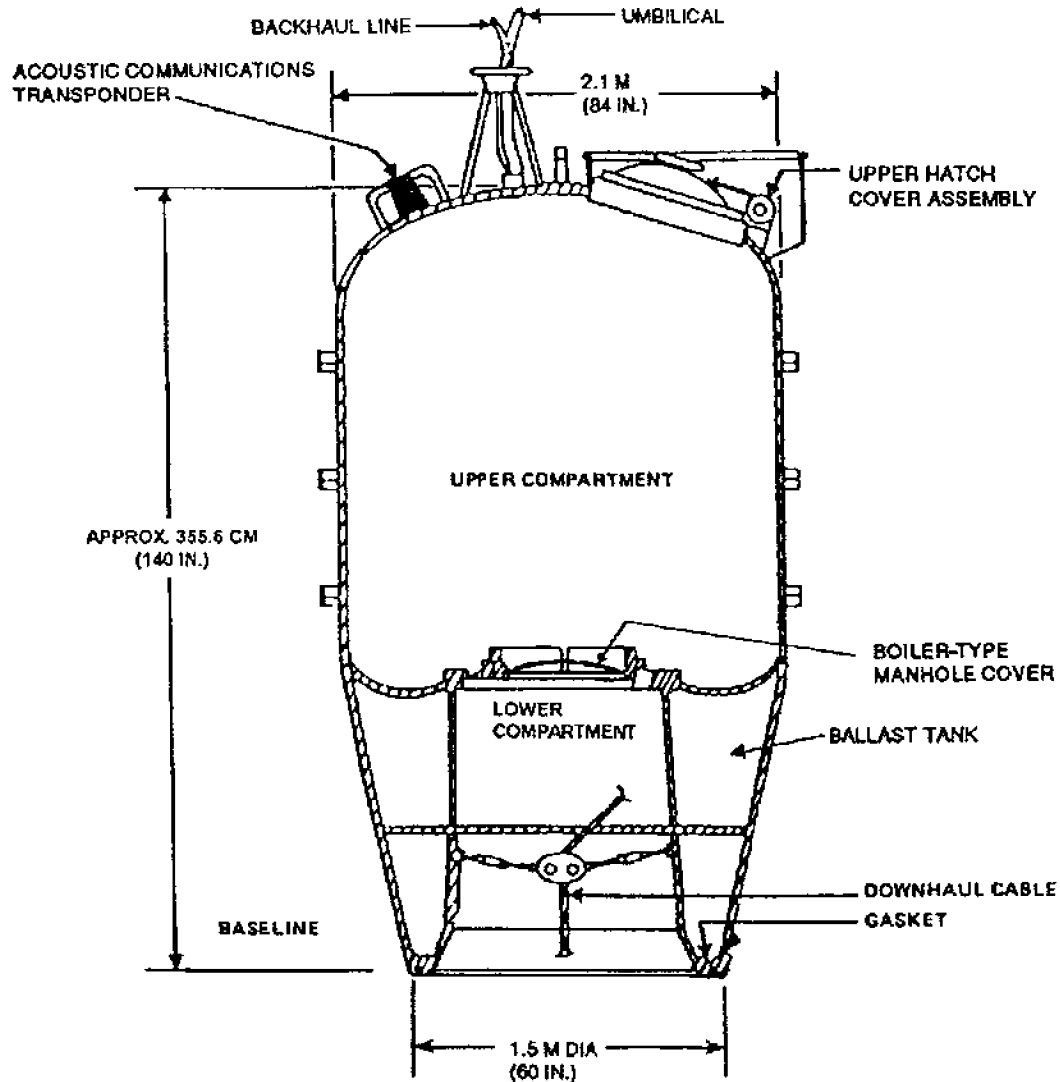

Figure 594-2-1 Submarine Rescue Chamber

594-2.1.3 EXTERIOR FEATURES. On the outside and top of the SRC are hull penetrations with watertight fittings for an air supply hose, an air exhaust hose, a communications cable, and an electrical power cable. A 25-inch, handwheel-operated, hinged, three-dog access hatch surrounded by a raised coaming permits entrance from the top of the SRC into the upper compartment. An oval-shaped, pressureproof, boiler-type manhole cover held in place with a strongback separates the upper and lower compartments. This manhole cover permits entrance into the lower compartment from the upper compartment after a seal has been achieved between the SRC and the DISSUB and pressure has been equalized between the upper and lower compartments.

594-2.1.4 UPPER COMPARTMENT. The upper compartment contains all the equipment and controls needed to operate the SRC. The compartment has room for two operators and six rescued personnel. During rescue operations, this compartment can be maintained at atmospheric pressure by periodic manual venting to the surface, or the upper compartment can be pressurized. Various support tools and equipment are also stored in the upper compartment.

594-2.1.4.1 Air Motor. An air-driven, reversible motor, located in the upper compartment, is connected to a

downhaul cable reel in the lower compartment by a drive train assembly that penetrates the two compartments through a watertight stuffing box. SRC operators can regulate air pressure to the motor to control ascent and descent of the SRC.

594-2.1.4.2 Ballast. Two types of ballast, fixed and variable, are carried in the upper compartment of the SRC. The SRC is normally ballasted with fixed lead or zinc ballast to 454 kilograms (1000 pounds) positive buoyancy with the ballast tank dry, the lower compartment full of water, a full load of variable ballast on board, and two operators in the upper compartment. Variable ballast is used to make up for the weight of the rescued personnel. The variable ballast, in the form of 544.3 kilograms (1200 pounds) of water, is stored in 12 cans or ballast bags in the SRC. After the SRC mates with the submarine and the rescued personnel are brought on board, the variable ballast is drained into the submarine. The empty ballast cans or bags are kept in the SRC. The variable ballast is replenished after each ascent.

594-2.1.4.3 Instrumentation. Various pressure gauges are located in the upper compartment. The upper compartment pressure gauge (caisson gauge) displays the air pressure in the upper compartment. The sea pressure gauge indicates the sea pressure and depth of the SRC. Other gauges are used to monitor the following: air supply pressure to the SRC, air motor supply pressure, lower compartment pressure, ballast tank pressure, emergency breathing system air pressure, and hydraulic cable cutter pressure.

594-2.1.4.4 Electrical Equipment. The SRC receives 120-volt, 60-cycle electrical power from the surface support ship with an overcurrent protection device rated at 25 amps. The 396-meter (1300 feet) long power cable connects to a MIL-C-24231 type electrical hull insert on top of the SRC to supply a four-circuit fused distribution panel in the upper compartment. The distribution panel controls two lights in the upper compartment, a receptacle, and two 250-watt pressureproof quartz halogen light fixtures in the lower compartment.

594-2.1.4.5 Communication Equipment. There are three ways to communicate with the SRC: the divers' speaker system, a sound-powered telephone, and an underwater telephone system. The underwater telephone is the primary means of communication between the SRC and the DISSUB.

594-2.1.4.6 Viewports. Two acrylic viewports equipped with protective covers are installed in the hull of the upper compartment for viewing the lower compartment and the downhaul cable and reel.

594-2.1.5 LOWER COMPARTMENT. The lower compartment contains the downhaul equipment and two pressureproof lights. It also provides access to the DISSUB.

594-2.1.5.1 Downhaul Equipment. The downhaul equipment is used to winch the SRC down to the DISSUB and to control the ascent back to the surface. The equipment consists of an air motor and drive train assembly located in the upper compartment; a downhaul mechanism made up of a gearbox, cable drum, spooling device, and a fairlead assembly; a hydraulic cable cutter operated by a handpump in the upper compartment; and an air motor lubrication system. The downhaul cable is a galvanized steel wire rope. This cable is 396 meters (1300 feet) long, and 11 millimeters (7/16 inch) in diameter. One end is secured to and wound around the cable reel. The other end has a swivel end fitting and a safety hook. During rescue operations, the safety hook is coupled to a shackle located near the center of the submarine's rescue/escape trunk upper access hatch (see [Figure 594-2-2](#)). The downhaul cable is attached by air or mixed gas divers (for shallow depths), saturation divers (for shallow depths), a Remotely Operated Vehicle (ROV) with a manipulator arm, a Deep Submergence Vehicle (DSV), or an Atmospheric Diving System (ADS) for deeper depths.

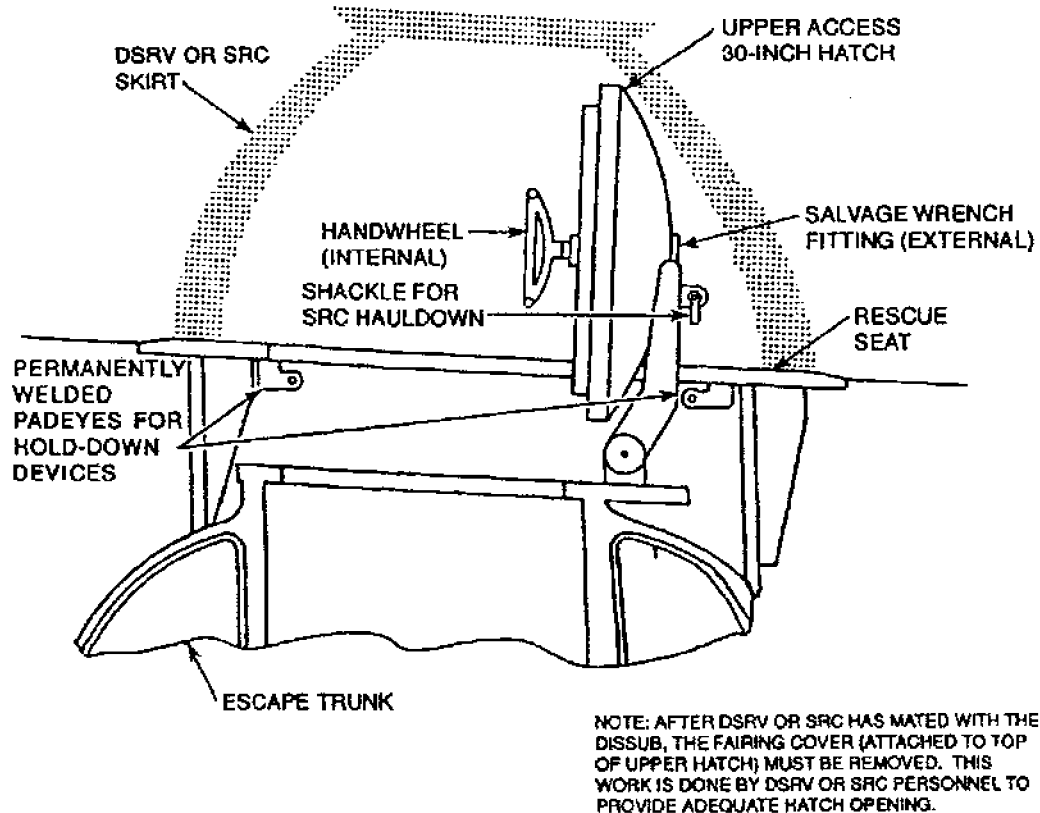

Figure 594-2-2 Features of Typical Rescue/Escape Trunk with 30-Inch Upper Access Hatch

594-2.1.5.2 Hold-Down Devices. Four hold-down devices, stored in the upper compartment, are used to hold the SRC securely to the rescue seat after a seal is made between the SRC and the DISSUB. These devices fit into beveled slots in a reinforced circular ring welded around the inside circumference of the lower compartment. The shackle or jaw end on the lower part of each device is secured to one of four attachment points located around the perimeter of the submarine's upper access hatch. Three types of attachment points are used. One type is a permanently welded staple that is typically used on SSN 637 and earlier classes of submarines that have 25-inch-diameter upper access hatches. On these submarines, the staples are normally attached to the outer hull. Another type of attachment point used is a permanently welded padeye (see Figure 594-2-2). SSN 688, SSBN 726, and SSN 21 class submarines have 30-inch-diameter upper access hatches with the padeyes installed below the level of the hatch fairing cover. To access these padeyes, the hatch fairing cover must be removed. These padeyes are being replaced with a threaded eyebolt referred to as a Portsmouth interlock. The threaded eyebolt is carried on the rescue vehicle and is installed by the SRC crew after a seal is made with the DISSUB. The eyebolts are installed into special threaded receivers that are welded into the submarine's structure, flush with the rescue seat. The eyebolt and receiver has three advantages over the welded padeyes:

1. It allows the rescue crew to install hold-down devices before removing the hatch fairing cover. On SSN 688, SSBN 726, and SSN 21 class submarines, which have the permanently welded type of padeyes, the hatch fairing covers must be removed to access the padeyes and to allow the 30-inch-diameter hatch to be opened to the maximum extent within the SRC skirt.
2. It is significantly stronger than the welded padeyes or staples.

3. It allows for increased submarine hatch opening angles within the rescue vehicle skirt for easier access between the submarine and the rescue vehicle.

594-2.1.6 BALLAST TANK. The ballast tank surrounds the lower compartment and can change the buoyancy of the SRC by approximately 1360 kilograms (3000 pounds). It is usually dry and kept at atmospheric pressure except when a seal is being made with a submarine. Removing the ten inspection covers that surround the ballast tank allows access to perform inspection and maintenance.

594-2.1.7 PIPING SYSTEMS. The SRC has several piping systems that allow it to work properly.

594-2.1.7.1 Air System. The air system provides air from the support ship for the crew to breathe. The air supplied is also used to operate the downhaul air motor, blow the ballast tank and the lower compartment, transfer water, and supply the emergency breathing system.

594-2.1.7.2 Flood and Drain System. The flood and drain system controls the flooding and draining of the ballast tank and the lower compartment. This system allows water to be directed into the ballast tank or lower compartment, transferred from one to the other, or blown to sea. The buoyancy of the SRC changes by about 1360 kilograms (3000 pounds) when the lower compartment is flooded or blown dry.

594-2.1.7.3 Spill and Vent System. The spill and vent system provides the ability to completely vent or drain the ballast tank when the SRC is seated at an angle on the submarine. The spill and vent system also provides the capability to flood and drain the ballast tank in an emergency.

594-2.1.7.4 Hydraulic System. A hydraulic system is used to operate the downhaul wire cable cutter in the lower compartment. It consists of a handpump and associated piping, valves, and pressure gauge. Should the downhaul cable become fouled, preventing the SRC from ascending or descending, the cable can be cut by the SRC operators. This will allow the SRC to float to the surface.

594-2.1.7.5 Emergency Breathing System. The emergency breathing system provides air for the SRC occupants to breathe if the SRC atmosphere becomes contaminated or the DISSUB atmosphere is toxic. The system consists of eight breathing masks with demand flow regulators and two manifolds.

594-2.1.7.6 Exhaust and Vent System. The exhaust and vent system allows the ballast tank and lower compartment to be vented, removes the air motor exhaust, and ventilates the upper compartment to the surface.

594-2.1.8 MISCELLANEOUS EQUIPMENT. The following equipment is required for proper operation of each SRC.

594-2.1.8.1 Hoses. Air is supplied to the SRC from the support ship through a wire-reinforced air supply hose with a 25-millimeter (1-inch) inside diameter. Air is vented to the surface through a wire-reinforced exhaust hose with 32-millimeter (1-1/4 inch) inside diameter. The hoses come in 15-meter (50-foot) lengths and are coupled together to form assemblies 396 meters (1300 feet) long.

594-2.1.8.2 Communication Cable. The communication cable consists of a cable 396 meters (1300 feet) long made of DLT special diving telephone and lifeline cable or its replacement, TSS-4 cable.

594-2.1.8.3 Backhaul Line. The backhaul line is a synthetic fiber rope with a minimum breaking strength of 596,032 newtons (134,000 pounds) and a length of 396 meters (1300 feet). The backhaul line is attached to a lifting eye welded to the top of the SRC. The backhaul line is used to tend the SRC from the surface and for emergency recovery; it is not used to lift the SRC from or onto the deck of the support ship. During SRC descent and ascent, the backhaul line stays slack to avoid overstressing the downhaul cable.

594-2.1.8.4 Lifting Pendant. The lifting pendant is a galvanized steel wire rope 0.9 meter (3 feet) long and 32 millimeters (1-1/4 inches) in diameter. It has a poured zinc socket, ring, and safety shackle assembly. The lifting pendant is used to handle the SRC during transfer from and to the support ship. The length of the pendant used depends on the requirements of the support ship.

594-2.1.8.5 Miscellaneous Tool Bag. A bag of mission-essential tools is stored in the SRC. These tools are required for emergency repairs and adjustments, and, when necessary, for removing and handling the fairing cover from over the submarine's upper access hatch.

594-2.1.8.6 Battle Lanterns. Four portable battle lanterns for emergency lighting are mounted in the SRC.

594-2.1.8.7 Lower Hatch Lifting Tackle. The lower hatch lifting tackle consists of 38 meters (125 feet) of 16-millimeter-diameter (5/8-inch) polyester line; a double-sheave luff tackle; and a single-sheave, 102-millimeter (4-inch) lifting block. The double-sheave luff tackle is secured to a padeye in the overhead of the upper compartment. The hatch lifting tackle is used for handling the submarine fairing cover pieces and fairing cover compensation weight, when necessary, and the SRC lower hatch. The lifting tackle is also used to help remove injured personnel from the submarine.

594-2.1.8.8 Protective Headgear. Eight sets of protective headgear, which should be worn at all times, are stored in the upper compartment for use by the SRC crew and rescued personnel.

594-2.2 SRC RESCUE OPERATIONS

594-2.2.1 GENERAL. The following section provides a general outline of the sequence of events that occurs when the SRC is used to perform a collective rescue. Before starting the rescue, the DISSUB crew should notify the rescue forces of the condition of the submarine as described in paragraph 594-1.2.6, prepare the rescue/escape trunk as described in the applicable ship system manual, and organize into groups of six to facilitate an orderly rescue. Refer to the applicable ship system manual and to NAVSEA SS750-AA-MMA-010/850 FT for detailed procedures to be followed by the submarine crew and the SRC operators during rescue operations.

1. After locating the DISSUB, the support ship establishes a four-point mooring with the center as near as possible over the DISSUB. The ship then moves up current of the submarine about 15 to 30 meters (50 to 100 feet).
2. A downhaul cable is connected to the shackle on the upper access hatch of the rescue/escape trunk designated to be used during the rescue operation. The submarine crew prepares the trunk in accordance with the applicable ship system manual.
3. The air supply hose is connected to air flasks on the support ship and to the proper fitting on the SRC. The air exhaust hose is secured with one end open to the atmosphere on board the support ship and the other end secured to the proper fitting on the SRC. The communication cable is connected to the SRC fitting and is plugged into the communication system's receptacle on the support ship. The power cable is plugged into

the support ship's electrical circuit and the other end is secured to the proper fitting on the SRC. The air lines, power cable, and communications cable are bound together to a 76-millimeter-diameter (3-inch) nylon rope strength member. This assembly is referred to as the umbilical. To allow the SRC to operate freely, the umbilical is kept slack during the descent and ascent. After all service connections from the support ship to the SRC are tested, the SRC is lowered over the side of the support ship. Pressure in the air supply line is kept at least 345 kiloPascals (kPa) (50 pound-force per square inch gage [psig]) higher than the ambient sea pressure or 1379 kPa (200 psig), whichever is greater.

4. When the SRC is ready for the descent, the operators board it through the upper hatch. After the upper hatch is closed and the lower compartment is flooded, the SRC descends to the DISSUB.
5. In shallow water (less than 61 meters [200 feet]) a seal is made between the SRC and the submarine by flooding the ballast tank, taking up the slack in the downhaul cable, blowing the lower compartment, and then venting the lower compartment to topside. This method of forming a seal can also be used at greater depths if the current or rescue seat conditions on the submarine will not allow a seal to be formed as described below.
6. The seal caused by sea pressure is enough to hold the SRC tightly against the rescue seat. This type of seal is made by rapidly transferring water from the lower compartment to the ballast tank. The SRC is intended for use in rescue operations in which the pressure within the DISSUB is at or near atmospheric pressure. All pressurized rescue operations should follow current diving practices and safety precautions to ensure that any required decompression is done properly.
7. After a seal is made and the SRC lower chamber is drained, the SRC crew instructs the submarine to drain the upper hatch cavity to equalize pressure between the submarine and the SRC (see [Table 594-2-1](#) for standard tap signals used between the SRC and DISSUB). The submarine crew then drains the trunk, if necessary. The pressure in the trunk and the access compartment should be the same before the lower access hatch to the trunk is opened.

Table 594-2-1 STANDARD SRC-DISSUB TAP SIGNALS

Sender	No. of Taps	Meaning
SRC	8 (in four pairs)	The SRC is sealed in position and the DISSUB should drain the upper access hatch cavity.
SRC	10 (in five pairs)	The DISSUB should open the upper access hatch after shutting the lower access hatch.
DISSUB	4 (in two pairs)	The upper access hatch cavity drain, trunk flood, and trunk drain valves are shut and the SRC may prepare to unseal.

8. On submarines that have been modified to use the threaded eyebolt, the SRC crew installs them. The SRC crew installs the hold-down devices and removes the downhaul cable and fairlead assembly. They then remove the submarine hatch fairing. Next, the SRC crew installs a compensating weight onto the hatch or, on SSN 21 class submarines, unscrews a spring retainer screw to compensate for the removal of the fairing.
9. On submarines with permanently welded padeyes or staples, the SRC crew removes the submarine hatch fairing, if necessary. On earlier classes of submarines with 25-inch-diameter upper access hatches, the fairings are not removed. The SRC crew installs the hold-down devices and removes the downhaul cable and fairlead assembly. The SRC crew then installs a compensating weight onto the hatch or, on SSN 21 class submarines, unscrews a spring retainer screw to compensate for the removal of the fairing.
10. The SRC crew directs the submarine's crew to open the upper access hatch and then the lower access hatch.
11. The fairing plates, if removed, and supplies as needed are transferred to the submarine. These supplies can include oxygen, lithium hydroxide canisters, water, food, clothes, medical supplies, etc.

12. Submarine personnel are brought aboard the SRC. The variable ballast is transferred to the submarine to make up for the submarine personnel brought on board the SRC. After the ballast is transferred to the submarine, the submarine crew is directed to close the upper access hatch and the hatch cavity drain valve, the trunk flood valve, and the trunk drain valve.
13. The SRC crew installs the fairlead assembly, attaches the downhaul cable to the hatch, removes the hold-down devices, and installs the boiler-type manhole cover between the upper and lower compartments. The SRC detaches from the DISSUB and returns to the surface.
14. A convenient way for the support ship to direct the SRC crew to answer a telephone call from the surface is to turn the master power switch off and on. The blinking lights in the SRC direct the crew to man the telephone, doing away with the necessity of keeping one operator tied continually to the phone. The phone on the surface should be manned at all times. The SRC's emergency underwater telephone should be energized to provide communication between the SRC and the submarine and between the SRC and the support ship. The emergency underwater telephone provides a means of communication if the normal telephone system fails during actual rescue operations.

SECTION 3.

COLLECTIVE RESCUE USING DEEP SUBMERGENCE RESCUE VEHICLE

594-3.1 DEEP SUBMERGENCE RESCUE VEHICLE (DSRV)

594-3.1.1 GENERAL. There are two DSRV's: DSRV-1 (Mystic) and DSRV-2 (Avalon). The primary mission of the DSRV is to provide a quick reaction, worldwide, all-weather capability to rescue personnel from disabled submarines (DISSUB) at depths of less than 610 meters (2000 feet). The DSRV's maximum operating depth is approximately 1524 meters (5000 feet). The DSRV can be transported by truck, aircraft, surface ship, or on a mother submarine. The DSRV can dive, locate the DISSUB, and attach itself to the DISSUB's rescue seat. After the DSRV is properly attached to the submarine, the DISSUB's access hatches are opened and submarine personnel can enter directly into the DSRV. The DSRV then detaches itself from the submarine and transfers the rescued personnel to the support ship, which can be a specially modified submarine or a surface ship. For a more detailed description of the DSRV system, refer to NAVSEA 0905-LP-120-0010, **Technical Manual for DSRV System** .

594-3.1.2 DESCRIPTION. The DSRV outer hull is approximately 15 meters (50 feet) long, 2.4 meters (8 feet) in diameter, and is constructed of formed fiberglass (see [Figure 594-3-1](#)). The DSRV weighs approximately 36 metric tons (80,000 pounds). Inside the fiberglass outer hull are three interconnected spheres that form the pressure hull. Each sphere is 2.3 meters (7-1/2 feet) in diameter and is constructed of high tensile strength steel. The spheres are connected by hatches that allow personnel to move within the DSRV. The forward sphere contains the vehicle's sophisticated control and navigation equipment and is manned by an operator and a co-operator. The center and after spheres accommodate up to 24 passengers and two DSRV crewman.

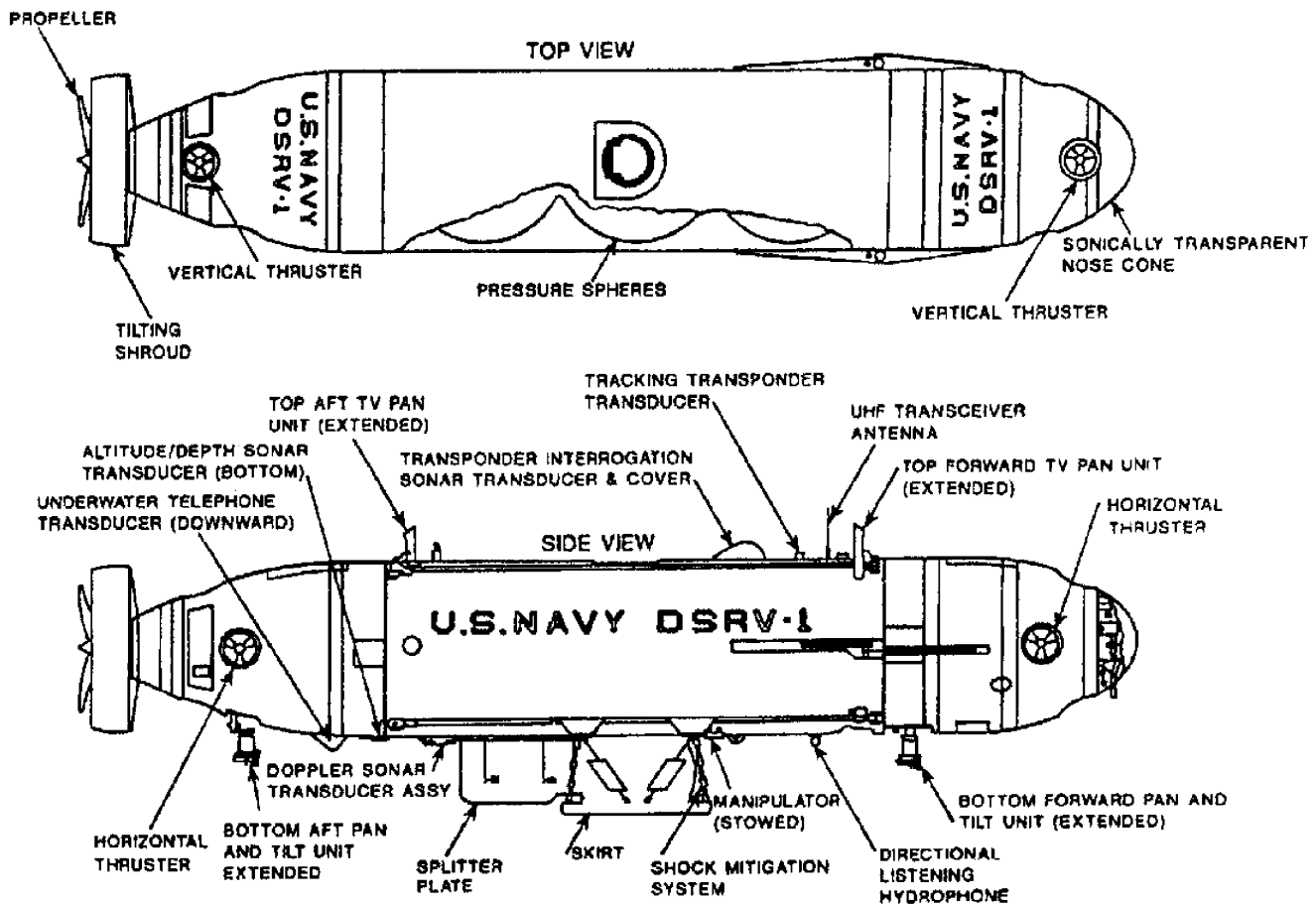

Figure 594-3-1 Deep Submergence Rescue Vehicle (DSRV)

594-3.1.3 DSRV SKIRT. Under the DSRV's center sphere is a hemispherical skirt and shock mitigation system that allows the DSRV to mate with the rescue seat on the submarine's rescue/escape trunk (see [Figure 594-2-2](#)). The skirt allows a watertight seal to be made between the DSRV and the submarine. After a seal is made, the submarine's upper access hatch can be opened and swung up into the skirt cavity.

594-3.1.4 DSRV PROPULSION AND CONTROL. Propulsion and control of the DSRV is provided by a conventional, battery-powered, stern propeller in a movable shroud; and four ducted thrusters, two forward and two aft. The system permits the DSRV to maneuver and hover in underwater currents. The DSRV can attach to a submarine inclined to angles up to 45 degrees from vertical in either the fore and aft or athwartships direction, with an internal pressure of up to 3-1/2 atmospheres, and exposed to a current of up to 2 knots.

594-3.2 DSRV RESCUE OPERATIONS

594-3.2.1 GENERAL. The following section provides a general outline of the sequence of events that occurs when the DSRV is used to perform a collective rescue (see [Figure 594-3-2](#)). Before starting the rescue, the DIS-

SUB crew should notify the rescue forces of the condition of the submarine as described in paragraph 594-1.2.6, prepare the rescue/escape trunk as described in the applicable ship system manual, and organize into groups of 24 to facilitate an orderly rescue. Refer to the applicable ship system manual for detailed procedures to be followed by the submarine crew.

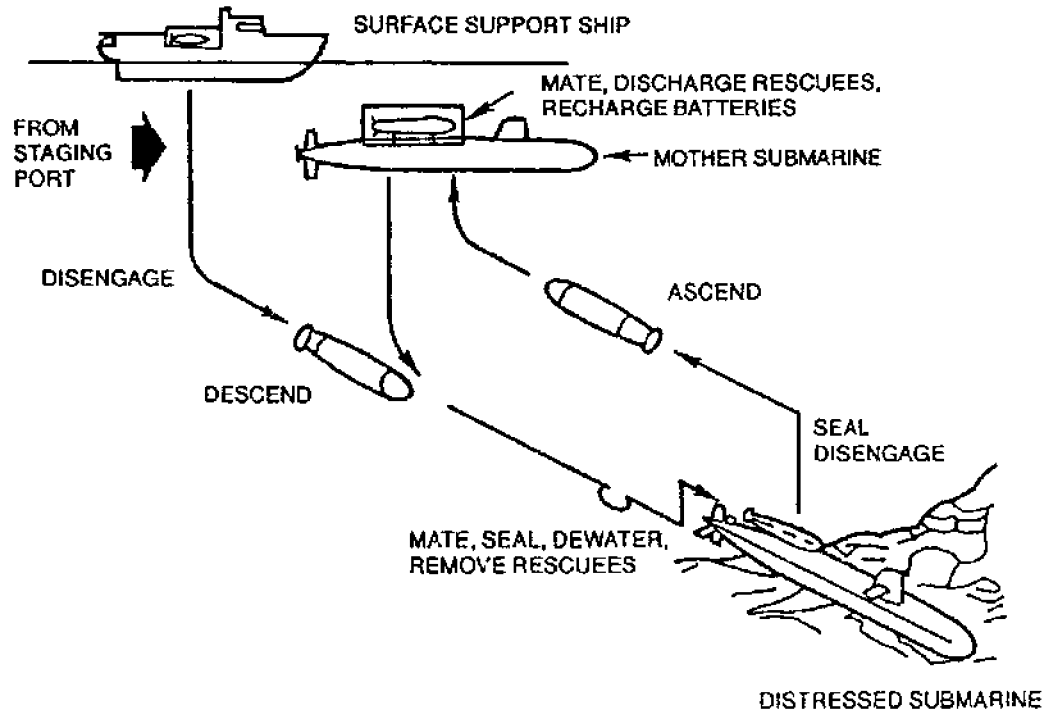

Figure 594-3-2 Typical Sequence of Events During DSRV Rescue Operation

1. Upon notification that a submarine is submerged and disabled, the DSRV and its support equipment are transported to a port near the submarine, then loaded on a support ship. For the rest of this discussion, the DSRV support ship will be assumed to be a submarine.
2. The mother submarine, with the DSRV mated to the after rescue/escape trunk and supported by four pylons, proceeds to the area of the DISSUB and serves as an underwater base for the DSRV. The mother submarine can launch and recover the DSRV at either the forward or after rescue/escape trunk while submerged.
3. As the DSRV descends to the DISSUB, it uses sonar to detect the submarine's AN/BQN-13 submarine distress pingers. The DSRV can detect the afterview of the sail of the smallest U.S. Navy submarine at about 450 meters (500 yards) under good acoustic and reverberation conditions. The DSRV can also establish and maintain voice communications with the submarine using the emergency underwater telephone.
4. After the DSRV has located the submarine's rescue/escape trunk and has landed on the rescue seat, the water in the DSRV mating skirt is pumped overboard or is vented to tanks on the DSRV. Depending on rescue conditions, such as depth of the submarine, underwater current, and angle of the submarine, the DSRV can use hold-down devices similar to those used by the SRC to ensure a watertight seal with the submarine.
5. When instructed by the DSRV (see Table 594-3-1 for standard tap signals used between the DSRV and DISSUB), the submarine's crew drains the upper hatch cavity, which equalizes the pressure between the DSRV and the submarine. The submarine crew then drains the trunk, if necessary.

Table 594-3-1 STANDARD DSRV-DISSUB TAP SIGNALS

Sender	No. of Taps	Meaning
DSRV	8 (in four pairs)	The DSRV is sealed in position and the DISSUB should drain the upper access hatch cavity.
DSRV	10 (in five pairs)	The DISSUB should open the upper access hatch after shutting the lower access hatch.
DISSUB	4 (in two pairs)	The upper access hatch cavity drain, trunk flood, and trunk drain valves are shut and the DSRV may prepare to unseal.

6. On submarines that have been modified to use the threaded eyebolt, the DSRV crew installs them, if necessary. The DSRV crew installs the hold-down devices and then removes the submarine hatch fairing. Next, the DSRV crew installs a compensating weight onto the hatch or, on SSN 21 class submarines, unscrews a spring retainer screw to make up for the removal of the fairing.
7. On submarines with permanently welded padeyes or staples, the DSRV crew removes the submarine hatch fairing, if necessary. On earlier classes of submarines with 25-inch-diameter upper access hatches, the fairing covers are not removed. The DSRV crew then installs the hold-down devices, if necessary. The DSRV crew then installs a compensating weight, if necessary, onto the hatch or, on SSN 21 class submarines, unscrews a spring retainer screw to compensate for the removal of the fairing.
8. The DSRV crew signals the submarine's crew to open the upper access hatch and then the lower access hatch. The pressure in the trunk and the access compartment should be the same before the lower access hatch to the trunk is opened.
9. The fairing plates, if removed, and supplies, as needed, are transferred to the submarine. These supplies can include oxygen, lithium hydroxide canisters, water, food, clothes, medical supplies, etc.
10. Submarine personnel are brought aboard the DSRV. Up to 1905 kilograms (4200 pounds) of variable ballast water can be transferred to the submarine to make up for the submarine personnel brought on board the DSRV. After the ballast and supplies are transferred, the submarine crew is directed to close the upper access hatch and the hatch cavity drain valve, the trunk flood valve, and the trunk drain valve.
11. The hold-down devices, if installed, are removed. The skirt is flooded and is equalized to sea pressure. The DSRV detaches from the submarine and returns to the mother submarine to discharge the rescued personnel.

SECTION 4.

INDIVIDUAL ESCAPE USING THE RESCUE/ESCAPE TRUNK

594-4.1 INDIVIDUAL ESCAPE

594-4.1.1 DEFINITION. Individual escape is defined as individual abandonment of the submarine by buoyant ascent through the water to the surface with the use of a submarine escape appliance (Steinke hood). This kind of escape can be made without assistance from a Deep Submergence Rescue Vehicle (DSRV) or a Submarine Rescue Chamber (SRC).

594-4.1.2 METHOD. This buoyant, free-breathing escape method is a relatively safe and rapid way to make individual escapes from a sunken submarine up to depths of 137 meters (450 feet). This method has been used successfully in open sea ascents from a depth of approximately 97 meters (318 feet) and in simulated ascents from a depth of approximately 137 meters (450 feet). Escape from depths as great as approximately 183 meters (600 feet) is physiologically feasible but poses a greater risk of injury to survivors (see [Figure 594-1-1](#)).

594-4.2 SUBMARINE ESCAPE APPLIANCE

594-4.2.1 GENERAL. The submarine escape appliance is also known as the Steinke hood (shown in [Figure 594-4-1](#)). It is used by submarine personnel and is designed to get them to the surface with a supply of breathable air. The appliance conforms to the requirements of MIL-E-23155, **Escape Appliance, Hooded, Air Inflat-able, with Pouch, Submarine Personnel**. Once on the surface, the appliance acts as a life preserver. The appliance's buoyancy chamber is inflated with breathable compressed air from connections in the submarine's rescue/escape trunk. The appliance can also be inflated using an oral inflation device attached on the front of it. The appliance is usually inflated orally only when testing its operation before entering the rescue/escape trunk or when using it as a life preserver on the surface.

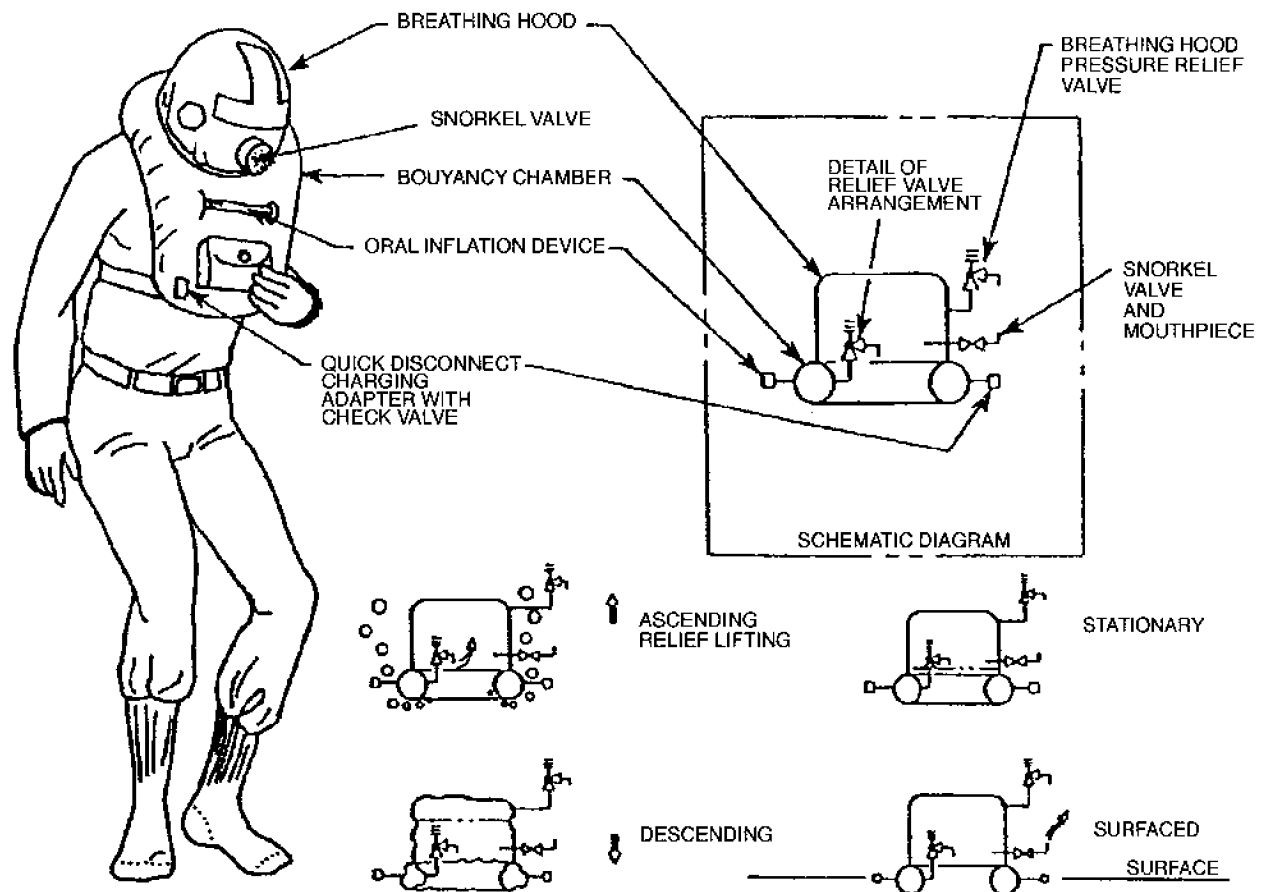

Figure 594-4-1 Submarine Escape Appliance

594-4.2.2 DESCRIPTION. The submarine escape appliance consists of the following items as shown in [Figure 594-4-2](#):

1. Buoyancy chamber
2. Breathing hood
3. Neck ring
4. Oral inflation device

5. Snorkel valve and mouthpiece
6. Charging adapter with check valve
7. Two pressure relief valves on the buoyancy chamber
8. Two pressure relief valves on the breathing hood
9. Zipper
10. Accessory pocket containing a whistle, sea-dye marker, and nose clip
11. Belt
12. Toggle line
13. Preserver stowage pouch
14. Personnel marker light
15. Reflective tape

The orange fabric breathing hood is attached to the orange buoyancy chamber. The buoyancy chamber has a connection that allows the chamber to be charged with compressed air through a charging manifold in the rescue/escape trunk.

During ascent to the surface, expanding air from within the buoyancy chamber passes through two relief valves and into the hood to ventilate it and keep it expanded. The escapee, with his head in the hood, has enough air available to breathe normally.

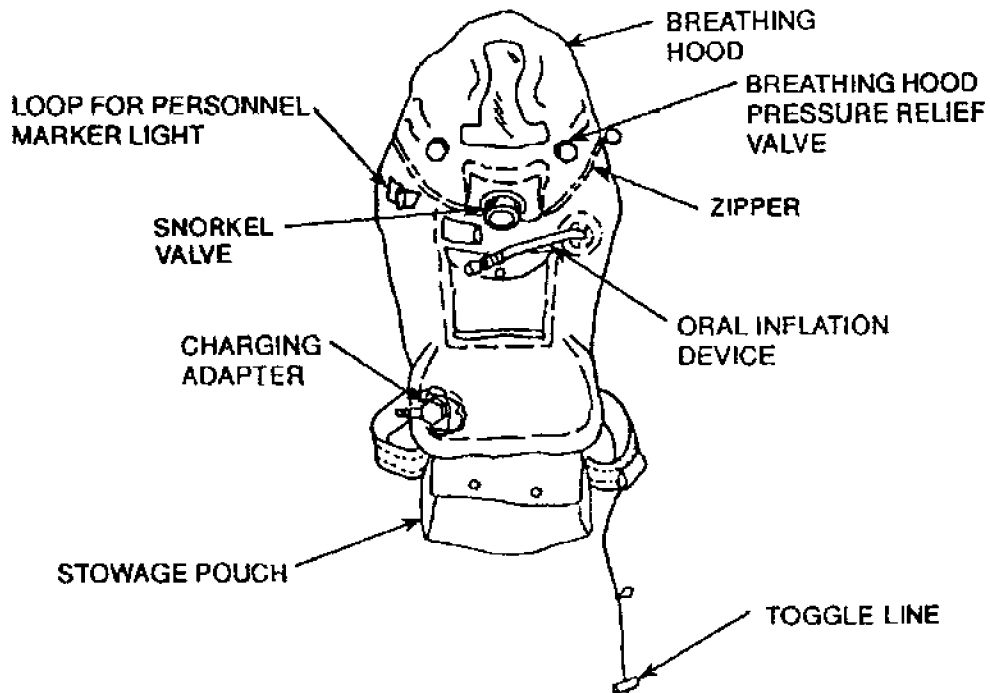
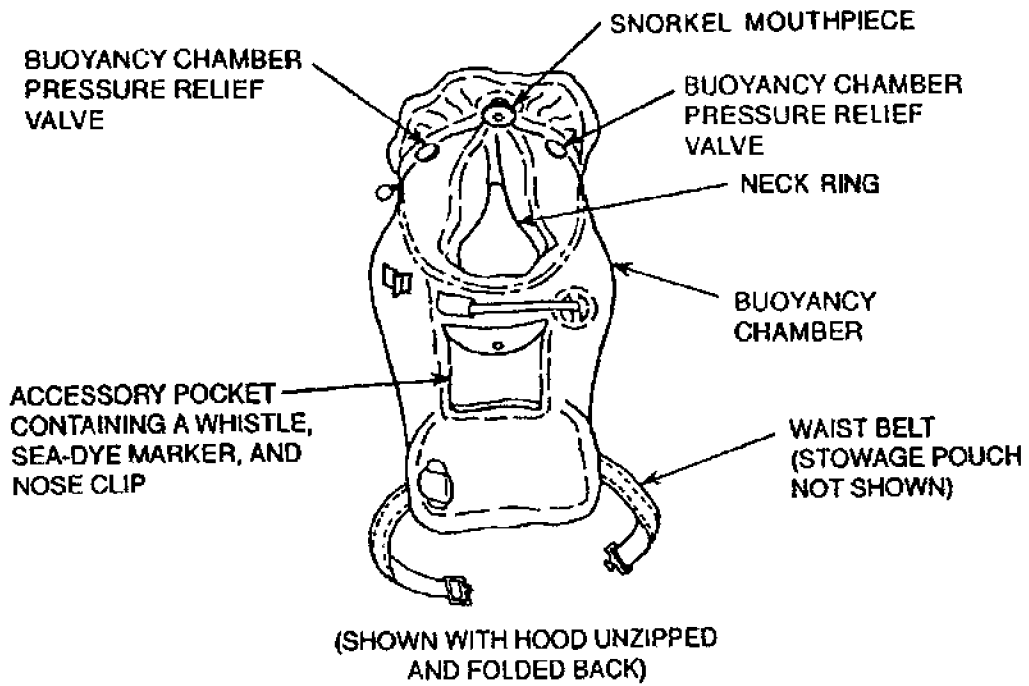

Figure 594-4-2 Detail View of Submarine Escape Appliance Features (Reflective Tape Not Shown)

594-4.2.2.1 Buoyancy Chamber. The buoyancy chamber is made of orange, neoprene-coated, nylon fabric. The chamber is constructed so that it forms a collar that allows the wearer to pass his head through it during use. When inflated, the buoyancy chamber provides the positive buoyancy necessary for ascent to the surface. While on the surface, the chamber provides the escapee with approximately 14 kilograms (30 pounds) of additional positive buoyancy. During ascent to the surface, air in the pressurized chamber expands and passes through two relief valves on the top of the chamber. This air passes into the breathing hood and supplies breathable air to the escapee.

594-4.2.2.2 Breathing Hood. A fabric hood is attached to the collar portion of the buoyancy chamber. A clear, T-shaped plastic face shield in the hood provides visibility.

594-4.2.2.3 Neck Ring. A neck ring made of neoprene-coated nylon stretch cloth is connected to the base of the collar. The neck ring prevents air from escaping from around the escapee's neck and out of the breathing hood during ascent.

594-4.2.2.4 Oral Inflation Device. An oral inflation device consisting of a tube and an oral inflation check valve is installed on the front of the buoyancy chamber. The valve can be secured in the closed position by rotating a knurled ring counterclockwise toward the mouthpiece on the valve. This prevents accidental opening of the valve, which could deflate the buoyancy chamber.

594-4.2.2.5 Snorkel Valve and Mouthpiece. A plastic snorkel valve with an attached neoprene mouthpiece in the breathing hood allows the escapee to breathe outside air while wearing the hood. When the valve is rotated to the OPEN position, the escapee can breathe outside air using the mouthpiece. When the valve is rotated to the CLOSED position, no air can pass through the mouthpiece.

594-4.2.2.6 Charging Adapter and Check Valve. A charging adapter and check valve are installed on the lower part of the appliance. The charging adapter is used with quick disconnect hose couplings on the escape appliance air charging manifold in the rescue/escape trunk. The check valve prevents air from escaping from the buoyancy chamber after the appliance is charged with compressed air and the charging hose is disconnected from the escape appliance.

594-4.2.2.7 Buoyancy Chamber Pressure Relief Valves. Two pressure relief valves are installed on top of the buoyancy chamber under the breathing hood on either side of the appliance. The valves are exposed to the difference in pressure between the buoyancy chamber and the interior of the breathing hood. During ascent to the surface, the valves automatically open to allow air expanding in the buoyancy chamber to vent into the hood. The valves have the following fixed open and reseal values: open at 12.1 kiloPascals (kPa) (1.75 pound-force per square inch gage [psig]) maximum and closed at 10.3 kPa (1.5 psig) minimum. The valves have a flow capacity of 0.16 cubic meter (5.5 cubic feet) per minute at a differential pressure of 20.7 kPa (3.0 psig).

594-4.2.2.8 Breathing Hood Pressure Relief Valves. Two pressure relief valves are located on the sides of the breathing hood. The valves are exposed to the difference in pressure between the inside of the hood and the surrounding seawater. The valves regulate the air pressure in the hood during ascent to the surface.

594-4.2.2.9 Zipper. A zipper is installed on the base of the hood and attaches it to the collar of the buoyancy chamber. The zipper allows enough of the hood to be detached from the buoyancy chamber so that the escapee can throw it behind his head when on the surface. A protective flap is provided on top of the zipper to keep it from chafing the escapee's neck.

594-4.2.2.10 Accessory Pocket with Whistle, Sea-Dye Marker, and Nose Clip. A pocket is provided on the front of the appliance for storing a whistle, sea-dye marker, and nose clip. The whistle and nose clip have lanyards for attaching to a metal grommet in the accessory pocket. The sea-dye marker is attached to the same grommet using a cord 1.2 meters (4 feet) long and 1.6 millimeters (1/16 inch) in diameter.

594-4.2.2.11 Belt. An adjustable waist belt of nylon webbing with an attached metal buckle holds the lower section of the appliance around the wearer's waist. The belt prevents the appliance from sliding over the wearer's head during use. A pad on the belt protects the wearer from chafing caused by the metal buckle rubbing on the skin.

594-4.2.2.12 Toggle Line. The toggle line is a nylon cord, approximately 0.9 meter (3 feet) long, with a wooden handle at the end. The toggle line is attached to the waist belt and is stowed in a small pocket there. The toggle line provides a way to lift the escapee into a boat or tie escapees together once on the surface.

594-4.2.2.13 Preserver Stowage Pouch. Each submarine escape appliance is supplied with a rubber-coated cloth pouch in which the appliance is stored. The pouch protects the appliance from damage during storage.

594-4.2.2.14 Personnel Marker Light. The appliance has a loop on the upper portion for attachment of a personnel marker light as described in **Naval Ships' Technical Manual (NSTM) Chapter 077, Personnel Protection Equipment** .

594-4.2.2.15 Reflective Tape. As described in **NSTM Chapter 077** , strips of reflective tape 51 millimeters (2 inches) wide are glued to various areas of the appliance (as shown in [Figure 594-4-3](#)) to make the escapee more visible while on the surface. The reflective tape is applied following the procedures in **NSTM Chapter 077** .

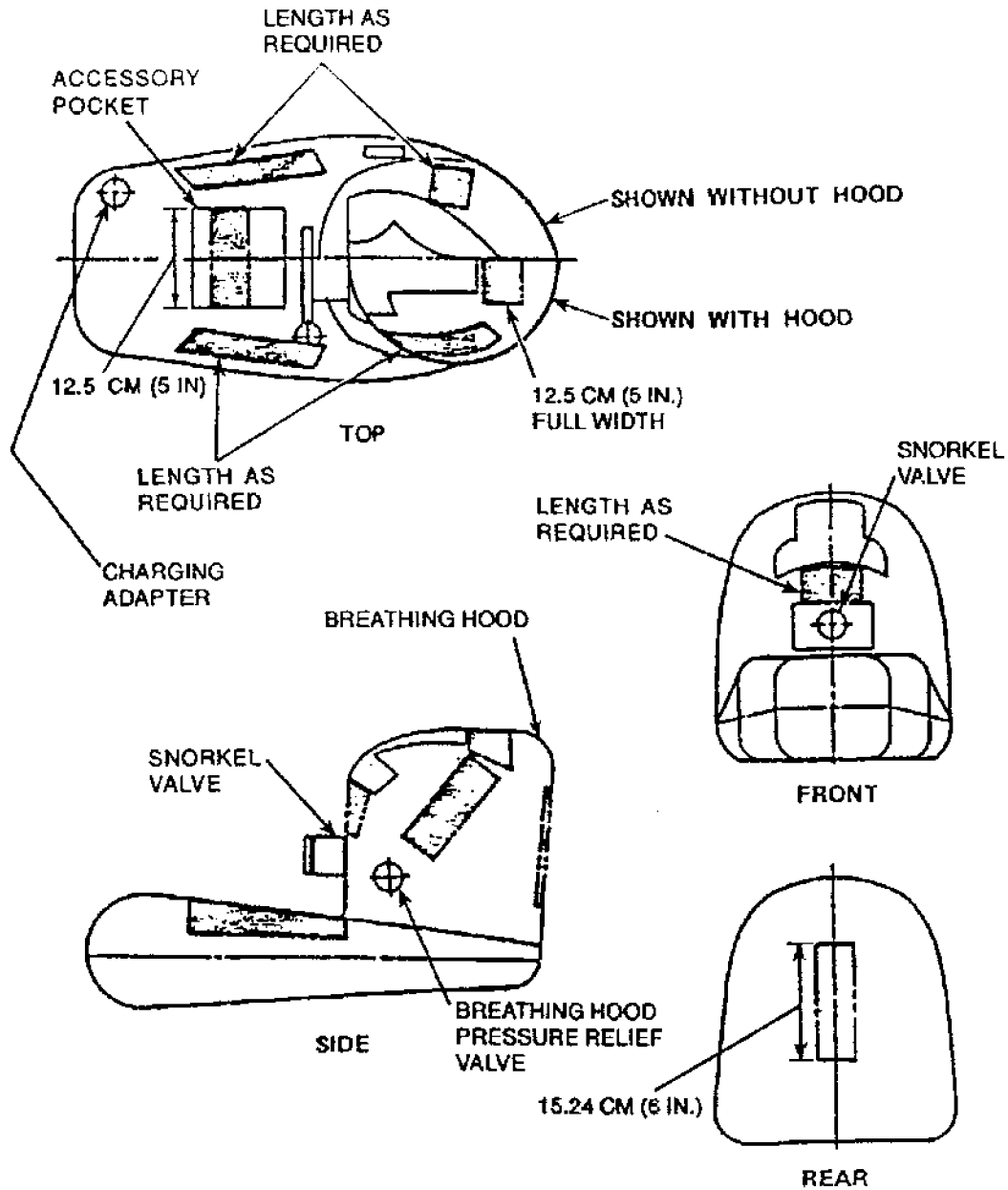

Figure 594-4-3 Reflective Tape Applied to Submarine Escape Appliance

594-4.2.3 DONNING AND ADJUSTING. Use the following procedures when donning the submarine escape appliance:

- a. Place the belt around your waist. Position the stowage pouch containing the appliance in front. Adjust the belt for comfort. The belt is properly adjusted if you can place the palms of your hands between the belt and your hip. The buckle should be on the right side and the chafing pad should be positioned between the metal buckle and your hip.
- b. Remove the appliance from the pouch. Pull the appliance upward and unroll it up over your chest. Ensure that the snorkel valve is in the OPEN position.

- c. Ensure that the toggle line, nose clip, whistle, personnel marker light, and sea-dye marker are attached. Ensure that the whistle's and sea-dye marker's lanyards are attached to the grommet inside the accessory pocket. Stow the whistle and sea-dye marker in the accessory pocket and the toggle line in the small pocket attached to the waist belt.
- d. Inspect the escape appliance for rips, tears, or any other defects. Any hole that is too small to be readily seen will not seriously reduce the appliance's effectiveness.
- e. Test the escape appliance for proper operation. Partially inflate the buoyancy chamber using the oral inflation device. To do this, the knurled ring must be turned fully clockwise. Holding the tube in one hand, grasp the mouthpiece in the mouth and push in toward the clamp to open the valve. With the valve open, breathe into the mouthpiece to inflate the buoyancy chamber. Once the buoyancy chamber is partially filled, release the mouthpiece and turn the knurled ring counterclockwise so that the mouthpiece cannot be depressed. Squeeze or press the appliance until air is released through the buoyancy chamber pressure relief valves into the hood. This indicates that the relief valves are working properly.

WARNING

While wearing the escape appliance with the hood on before exiting the rescue/escape trunk, breathe through the snorkel valve and mouthpiece to avoid a buildup of carbon dioxide in the hood.

- f. Open the snorkel valve, put on the nose clip, and pass the head through the neck ring and collar.
- g. Grip the snorkel valve mouthpiece with your teeth. Breathe only through the mouthpiece and snorkel valve when wearing the hood to prevent a buildup of carbon dioxide in the hood.
- h. If not immediately entering the rescue/escape trunk, remove your head from the hood and carry the appliance over one arm.

594-4.2.4 MAINTENANCE. The submarine escape appliances should be examined carefully before being stowed aboard the submarine and periodically inspected during stowage to ensure their usability. Inspection and maintenance shall be performed in accordance with normal maintenance requirements.

594-4.2.5 STOWAGE. Each submarine escape appliance should be properly folded and stored in the attached rubber-coated cloth stowage pouch. Use the following procedure to prevent damage when packing the appliance into the pouch:

- a. Deflate the appliance using the oral inflation device and lay it flat.
- b. Rotate the snorkel valve to OPEN and cover it with a clean rag.
- c. Push the snorkel valve inward toward the breathing hood, leaving the rag in place to prevent damage to the appliance as it is folded.

CAUTION

Do not bend or crease the oral inflation device tube.

- d. Fold the sides of the appliance in 51 millimeters (2 inches) to 76 millimeters (3 inches) toward the center of the appliance.
- e. Flatten out the hood.

CAUTION

Do not crease the plastic face shield.

- f. Press the plastic face shield inward until it dishes. Make sure that it does not crease.
- g. Place the lower part of the appliance into the pouch.
- h. Roll the appliance down from the top until it is in the pouch.
- i. Snap the flap on the pouch shut.

594-4.2.6 PLASTIC FACE SHIELD REPAIR. Because of improper folding, cracks have formed in the plastic face shields on some submarine escape appliances. A procedure has been developed to repair the face shield using polyethylene tape (Minnesota Mining and Manufacturing Co. No. 480 polyethylene film tape). Properly applied in accordance with the following steps, the tape suitably repairs the face shield. Repair the face shield as follows:

- a. Wash the inside and outside of the face shield with soap and water.
- b. Rinse it thoroughly and wipe it completely dry.
- c. Cut the 51-millimeter- (2-inch-) wide tape into strips 51 millimeters (2 inches) long.
- d. Using a suitable rounded surface for a backing (e.g., a coffee mug, etc.), lay out the cracked area of the face shield as smoothly as possible.
- e. With the rounded backing in place, center the adhesive tape strips lengthwise, allowing about 25 millimeters (1 inch) on either side of the crack. Press down firmly to remove as many air pockets as possible.
- f. If more than one piece of tape is needed to properly seal the crack, overlap each piece by approximately 6 millimeters (1/4 inch) following the instructions in step e.
- g. Repeat steps c. through f. on the inside of the face shield.
- h. Visually inspect both sides of the face shield to ensure that the crack is properly sealed.
- i. Repack the appliance as described in paragraph [594-4.2.5](#).

594-4.3 SUBMARINE RESCUE/ESCAPE TRUNK

594-4.3.1 DESCRIPTION. Submarines normally have identical cylindrical rescue/escape trunks ([Figure 594-4-4](#) and [Figure 594-4-5](#)) serving each main compartment. Each trunk typically holds two individuals at a time when being used during individual escape. Each trunk is closed at the top and bottom by hatches and is equipped with the necessary systems to permit flooding, pressurizing, venting, and draining. These functions can be controlled from within the trunk and below it in the access compartment to the trunk. It is also possible to operate the upper access hatch used for escape from within the submarine.

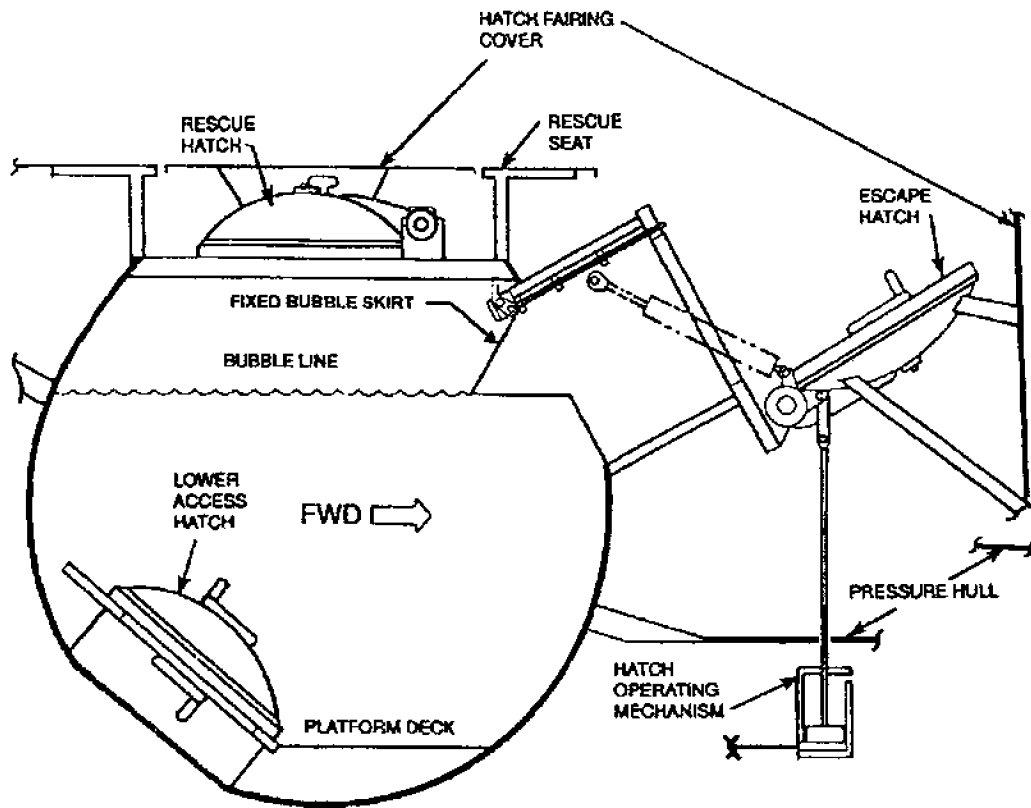

Figure 594-4-4 Typical Rescue/Escape Trunk on SSN 637 and Earlier Classes

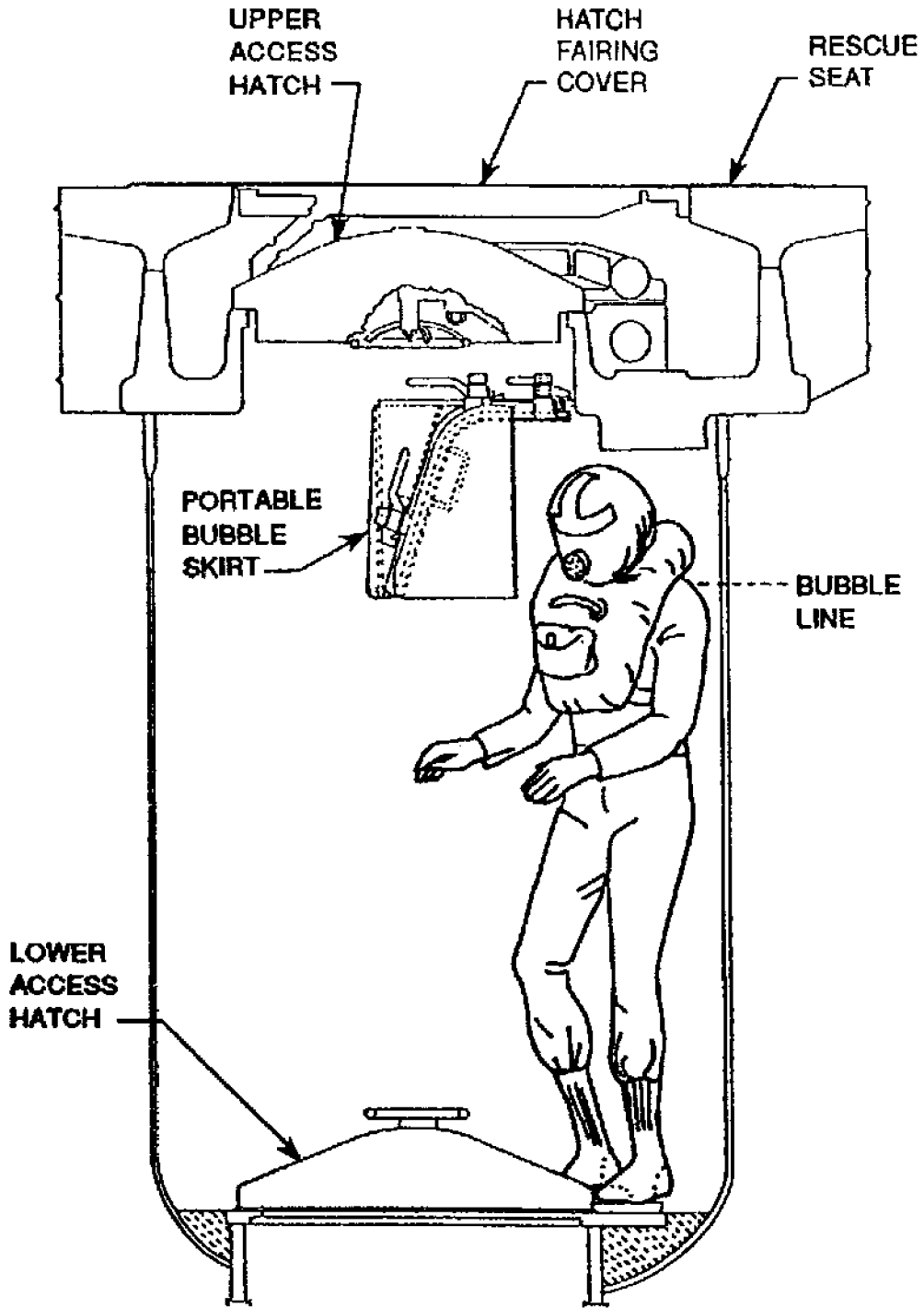

Figure 594-4-5 Typical Rescue/Escape Trunk with Portable Skirt on SSN 688 and Later Classes

594-4.3.2 FEATURES. Rescue/escape trunks have the following features (Figure 594-4-4, Figure 594-4-5, and Figure 594-4-6) that allow them to be used for individual escape from the submarine using a submarine escape appliance.

594-4.3.2.1 Hatches. Each trunk typically has 30-inch-diameter upper and lower access hatches. Earlier classes of submarines, such as SSN 637, have three 25-inch-diameter hatches as shown on Figure 594-4-4. The lower hatch is spring-balanced for manual opening and closing. The upper hatch is spring-balanced for manual opening and has a mechanical or hydraulic mechanism to assist in operating the hatch from within the submarine. On earlier classes of submarines with separate rescue and escape hatches, the escape hatch has a mechanism to assist in its operation.

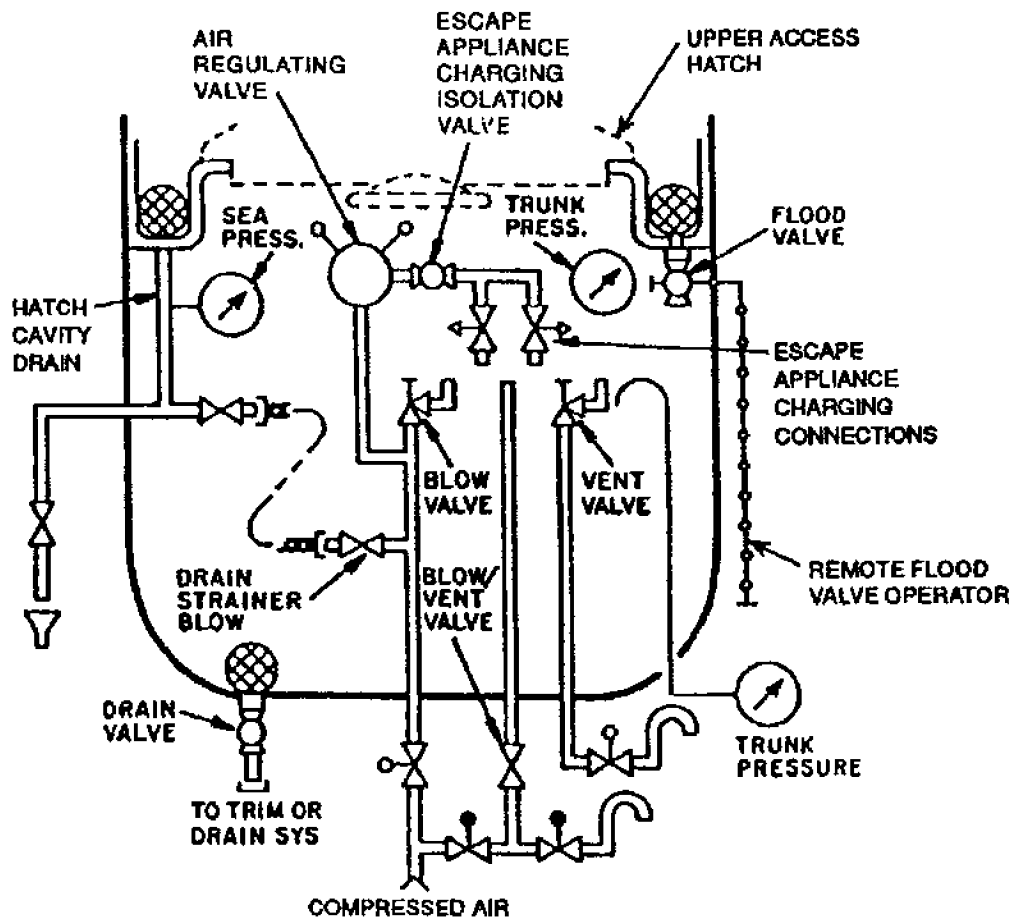

Figure 594-4-6 Typical Rescue/Escape Trunk Features

594-4.3.2.2 Portable Bubble Skirt. A portable bubble skirt is installed in the rescue/escape trunk for use during escape operations. The skirt traps an air bubble at the top of the trunk. This allows the escapees to maintain their heads above water after the trunk is flooded. SSN 637 class and earlier submarines have fixed bubble skirts. SSN 688 class and later submarines typically have portable bubble skirts. The portable skirt has a rubber gasket and manually operated dogs for sealing against a mating surface in the trunk.

594-4.3.2.3 Flooding System. The flooding system is used to fill the trunk with seawater to the bubble line in preparation for escape. The system typically consists of a manually operated, two-position ball valve and tail-

piece with a two-station operator. The two-station operator permits the valve to be operated from either inside the trunk or from below the trunk in the access compartment.

594-4.3.2.4 Blow and Vent System. The blow and vent system is used to pressurize the trunk when it is flooded, reduce the concentration of carbon dioxide in the trunk, and reduce the pressure in the trunk at the end of the escape procedure. This system can be operated from inside the trunk or from below the trunk in the access compartment. The system typically has redundant piping penetrations with associated valves rather than a single valve with dual controls.

594-4.3.2.5 Air Charging System. The air charging system, which is supplied from the trunk blow and vent system, is provided to charge the submarine escape appliances with breathable air. The air is supplied through a regulating valve that is normally set for 100 psi above ambient trunk pressure. The air passes through an isolation valve to a manifold typically containing two escape appliance charging connections.

594-4.3.2.6 Trunk Drain System. The trunk drain system typically consists of a valve mounted at the bottom of the trunk below the level of the lower access hatch coaming. Any accumulated water can be drained to the main drain system, trim and drain system, or the compartment, depending on the location of the trunk and the conditions in the submarine. For detailed information on draining the trunk, see the applicable ship systems manual.

594-4.3.2.7 Upper Hatch Cavity Drain System. The upper access hatch is recessed below the molded line of the submarine's hull, which creates a large cavity in which water is trapped after the submarine surfaces. The upper hatch cavity drain system provides the piping necessary to drain this area before opening the upper access hatch.

594-4.3.2.8 Overhead Light. A lamp is installed in the trunk above the bubble line for light. The lamp is energized by either the normal or emergency lighting system through a selector switch installed below the trunk in the access compartment.

594-4.3.2.9 Portable Hand Lanterns. Battle lanterns and mounting brackets are installed in the trunk above the bubble line or are stored below the trunk in the access compartment. The lanterns provide lighting if the overhead light fails.

594-4.3.2.10 Loudspeaker. A loudspeaker, which is part of the amplified communications system (IC circuit 31MC), is mounted above the bubble line. The loudspeaker allows the occupants of the trunk to communicate with the personnel below the trunk in the access compartment. A similar loudspeaker is also located below the trunk in the access compartment.

594-4.3.2.11 Hammer Signal Code Plate. The hammer signal code plate is mounted on the inside of the trunk above the bubble line. The plate contains information necessary for escapees to communicate by hammer taps with parties outside the trunk in case all other communication fails. A similar plate is located below the trunk in the access compartment.

594-4.3.2.12 Allowable Bottom Time Chart. The allowable bottom time chart is installed in the trunk above the bubble line. This chart provides a list of times versus depths of the submarine that the escapees must not exceed after the trunk is pressurized. A similar allowable bottom time chart is located below the trunk in the access compartment.

594-4.3.2.13 Hammer. A hammer mounted above the bubble line is provided for communicating with personnel outside of the trunk in case all other communication systems have failed. A hammer is also located below the trunk in the access compartment.

594-4.3.2.14 Valve Persuader. A short piece of pipe is mounted above the bubble line on some classes of submarines. This piece of pipe is used to assist in opening and shutting the flood valve during escape operations. The pipe is installed on the end of the valve handle for more leverage when attempting to open the valve.

594-4.3.2.15 Diver's Knife. A diver's knife is stowed in the trunk and is used to clear away objects that may obstruct an escape or prevent proper seating of the upper access hatch.

594-4.3.2.16 Mechanical Timer. A mechanical timer is installed in the trunk above the bubble line. The timer is spring-driven and comes equipped with a knob that allows the timer to be wound up before use.

594-4.3.2.17 Steinke Hood Operating Procedure Plate. The Steinke hood operating procedure plate is mounted on the inside of the trunk above the bubble line. The plate provides instructions on how to properly inflate and use the escape appliance.

594-4.4 INDIVIDUAL ESCAPE PROCEDURE

594-4.4.1 GENERAL. Because of the variety among submarine classes, detailed escape procedures are not contained here. To conduct successful individual escape operations, refer to the applicable ship systems manuals for detailed instructions and procedures for using the rescue/escape trunk.

594-4.4.2 PHYSIOLOGICAL EFFECTS DURING INDIVIDUAL ESCAPE. Escape operations subject the human body to certain physiological stresses that, if not understood and accounted for, can result in severe injury or death. For detailed information on these physiological effects, see NAVSEA 0994-LP-001-9010, **U.S. Navy Diving Manual Volume 1 (Air Diving)** .

594-4.4.2.1 Effects of Increased Pressure on the Body. Increased atmospheric pressure in the submarine, such as might occur during a flooding casualty, increases the amount of nitrogen that is absorbed in the body. This increased amount of nitrogen can produce bubbles in the body upon depressurization during return to the surface. These nitrogen bubbles can form in joints, blood vessels, and the brain if the body cannot eliminate the gas as it depressurizes. These bubbles can cause extreme pain, paralysis, and even death. This problem is called decompression sickness (DCS) or the "bends." The total atmospheric pressure and the time one is exposed to this pressure are interrelated variables that affect the amount of nitrogen dissolved in the body tissues, the related risk of developing DCS, and the need for decompression treatment upon reaching the surface. In general, body tissues are considered to have absorbed the maximum amount of nitrogen after exposure to a pressurized atmosphere for 24 hours. Therefore, personnel preparing to escape from a pressurized submarine may already be saturated with nitrogen. During the escape procedure, personnel are rapidly exposed to higher pressures as the rescue/escape trunk pressure is equalized with the surrounding sea pressure. This will increase the amount of nitrogen in the

body even more. During the ascent to the surface, the escapee will experience rapid decompression, which may lead to the development of DCS. The ascent rate when using the Steinke hood is 129.5 meters per minute (425 feet per minute). To minimize the risk of developing DCS upon reaching the surface, the elapsed time from initial trunk pressurization until exit of the last escapee must be as short as possible. An allowable bottom time chart is posted in each trunk; the maximum allowable exposure times listed on the chart apply to escape from an unpressurized submarine. In general, all escapees should exit the trunk as soon as possible after the trunk is pressurized.

594-4.4.2.2 Effects of Rapid Pressurization on the Ears. As the trunk is flooded and pressurized, the rapid increase in air pressure may cause discomfort to the ears of individuals in the trunk. An escapee who is unable to equalize the ear pressure may feel some pain. This condition is temporary and must not be allowed to delay the escape procedure. In extreme cases, the eardrums may rupture. Escapees should continue the escape procedure and exit the trunk within the allowable bottom time limits despite any discomfort to their ears. Failure to do so may result in much more serious injury as a result of DCS. A ruptured eardrum will cause short-term physical discomfort, but there is normally no permanent damage unless the injury is left unattended.

594-4.4.2.3 Effects of Increased Concentrations of Carbon Dioxide in the Atmosphere. The air pocket formed at the top of the rescue/escape trunk after the trunk is flooded is relatively small. Unless this air pocket is ventilated, breathing within the air pocket will increase the concentration of carbon dioxide to dangerous levels, which could lead to asphyxiation. As the rescue/escape trunk is pressurized during the escape process, even low concentrations of carbon dioxide in the air pocket can be hazardous, since the body will tend to absorb more carbon dioxide as the pressure is increased.

594-4.4.2.4 Effects of Increased Concentrations of Nitrogen on the Body. Breathing inert gases at pressure can cause a state of stupor or unconsciousness called narcosis. The most common form is nitrogen narcosis. Nitrogen narcosis can occur while breathing compressed air at depth, for example, when conducting escape operations. The narcotic effects of nitrogen will affect each individual differently, varying with the depth at which the individual is located or the pressure of the air the individual is breathing. The effects may first be noticed at depths greater than 100 feet of seawater (fsw) and will become more pronounced at depths greater than 150 fsw. The symptoms of nitrogen narcosis include confusion; impaired judgement; a sense of well-being or euphoria; slower reaction time and reflexes; lack of concentration; and difficulty in reasoning, remembering what to do, remembering what has already been done, and making accurate observations. Someone developing nitrogen narcosis may show signs such as: loss of judgment or skill; false feeling of well-being; and tingling and numbness of the lips, gums, and legs. The ability to concentrate and reason may become impaired; affected individuals may be unable to follow instructions or perform simple tasks. This may affect their ability to properly perform the steps necessary for escape. There is no specific treatment for nitrogen narcosis. To alleviate its effects, individuals must be removed from the pressurized environment or brought to shallower depths where the effects are not felt.

594-4.4.3 GENERAL STEPS TAKEN WHEN PREPARING TO ESCAPE. The following general steps are ordinarily taken when preparing to escape the submarine through the rescue/escape trunk using the submarine escape appliance:

1. All available hand lanterns and flashlights, along with the rubber life raft, are assembled in the access compartment below the rescue/escape trunk.
2. The support systems for the trunk are aligned and operating per the applicable ship system manual.
3. The portable bubble skirt, if applicable, is installed inside the trunk.
4. Personnel put on extra clothing, heavy socks, and watch caps for protection from exposure after reaching the

surface. They button up their shirts, turn up their collars, and tuck their pant legs into their socks. They remove shoes and leave keys, coins, and any other items that will weigh them down.

WARNING

If wearing the escape appliance with the hood on before exiting the trunk, the escapee shall breathe through the snorkel valve and mouthpiece to avoid a buildup of carbon dioxide in the hood.

5. Personnel don, adjust, and properly test the submarine escape appliance as described in paragraph 594-4.2.3.
6. If available, a diver's depth gage can be used to monitor the internal pressure of the disabled submarine (DISSUB). By knowing the DISSUB's internal pressure and depth, Figure 594-1-1 can be used to monitor the probability that survivors will develop DCS upon reaching the surface.
7. The DISSUB's roll and pitch angles should be verified. The roll and pitch angle at which the DISSUB is resting can affect how far the upper access hatch will open during the escape process. Where the remote upper access hatch operating mechanism permits, such as on SSBN 726 class submarines, the crew below the trunk in the access compartment should help to open the upper access hatch during the escape.
8. All personnel should familiarize themselves with the escape procedure and with the features of the rescue/escape trunk.

594-4.4.4 GENERAL PROCEDURE FOR BUOYANT FREE-BREATHING METHOD OF SUBMARINE ESCAPE. The following section provides a general outline of the sequence of events that occurs when using the trunk and the submarine escape appliance for individual escape. Detailed procedures are contained in the applicable ship system manual. Note that the following general procedure refers to the portable bubble skirt, which is not used on SSN 637 class and earlier submarines. Also, the procedure does not refer to side escape hatches, which are on rescue/escape trunk designs that use three hatches, such as those on SSN 637 class and earlier submarines (see Figure 594-4-4).

WARNING

The trunk flood valve is to remain shut until the lower access hatch is closed and dogged to prevent inadvertent flooding of the access compartment.

1. The trunk is drained and vented and the upper hatch cavity drain should be blown to clear any debris that may prevent rapid flooding of the trunk.

WARNING

The trunk shall be ventilated with fresh air to prevent carbon dioxide from building up in the air bubble while personnel are in the trunk and breathing through the snorkel valves.

2. One or two individuals enter the trunk wearing the deflated submarine escape appliance and breathing through the snorkel valve using the mouthpiece.
3. The lower access hatch is shut and dogged after the escapees are in the trunk. The trunk is ventilated with fresh air for approximately 1 minute to prevent the concentration of carbon dioxide in the air bubble from reaching toxic levels.
4. The timer is set to agree with the time shown on the allowable bottom time chart for the depth indicated on the sea pressure gauge in the trunk.
5. The escapees connect the escape appliances to the air charging manifold. The valve that controls air to the manifold is left shut and the valves that control air to the charging hoses are opened.
6. The escapees undog the upper access hatch and verify visually that the hatch locking ring lugs are centered between the trunk coaming lugs.
7. The escapees flood the trunk to the bubble line inscribed in the trunk or to the lower edge of the portable bubble skirt if the disabled submarine is not at 0 degrees pitch and 0 degrees roll.
8. The trunk is ventilated with fresh air for at least 15 seconds to prevent the concentration of carbon dioxide in the air bubble from reaching toxic levels.
9. The trunk vent valve is closed.
10. The charging valve manifold isolation valve is opened to allow the escape appliances to completely charge as the trunk is pressurized. The appliances are completely charged when air passes through the buoyancy chamber pressure relief valves and into the hood.

WARNING

To prevent developing DCS upon reaching the surface, escapees shall exit the trunk as soon as possible after the trunk is pressurized and before the applicable time on the allowable bottom time chart is exceeded.

11. The mechanical timer is started at the same time trunk pressurization begins. The trunk is rapidly pressurized. The upper access hatch will open as the trunk pressure equalizes with sea pressure, and the rest of the trunk opposite the portable bubble skirt will fill with seawater.
12. The pressurization of the trunk is secured when the upper access hatch opens.
13. To begin the ascent to the surface, the escapee exhales completely, then takes a deep breath and holds it. The snorkel valve is shut and the mouthpiece is removed from the mouth. The escape appliance is disconnected from the charging manifold and the escapee should start to breathe normally from the air volume in the hood. The escapees should exit the trunk as soon as possible to avoid exceeding the allowable bottom time.
14. The escapees duck under the skirt, one at a time, and exit the trunk by passing through the upper hatch. The last man out signals using the 31MC circuit or by hammer taps that the escapees have exited the trunk. If the hammer is used, it should be secured to the inside of the trunk before exiting, not dropped to the bottom of the trunk. If the hammer is dropped to the bottom of the trunk, it may foul the lower access hatch and prevent it from opening.

WARNING

Failure to forcibly exhale during the entire ascent to the surface may cause an air embolism, resulting in death.

15. Upon exiting the trunk, the escapees extend their hands above their heads and clasp their thumbs together to help guide themselves to the surface and to avoid debris and other survivors. During the ascent, the escapees should forcibly exhale to ensure that pressure does not build up in their lungs. The escapees can shout "HO-HO-HO" as a way to continually exhale during the ascent.
16. Upon reaching the surface, the snorkel valve is opened and the escapees should breathe through the mouth-piece. More air can be added to the escape appliance by using the oral inflation device. Survivors should stay together to be more visible to search and rescue personnel. It is much easier to locate a group of individuals in the water than a single person. Survivors should use the toggle lines on their escape appliances to tie themselves together. Whistles should be used to signal approaching ships and personnel marker lights should be used at night to signal search and rescue personnel. Individuals should take turns using their sea-dye markers to make their location more visible from the air.
17. If an inflatable raft is available, any injured survivors should be placed in it and the rest of the survivors should hang onto the sides. The inflatable raft should be sent to the surface last.
18. Death from hypothermia is a major concern for survivors on the surface. The body loses heat about 24 times faster in water than in air of the same temperature. The effects of hypothermia are immediate and rapidly disabling. Hypothermia can occur in water as warm as 22 degrees C (72°F). Survivors should keep their hoods on and their heads out of the water to minimize heat loss through the head. Survivors should not swim. Swimming increases the loss of body heat. Survivors should maximize body contact by grouping together as much as possible, hugging one another, and intertwining their legs.
19. If alone, a survivor should assume the Heat Escape Lessening Posture (HELP) position to cut heat loss from the head, chest, and groin. To assume the HELP position, the head should be kept out of the water and the legs should be pulled up to the chest and held in place by wrapping the arms around the knees.
20. After waiting at least 1 minute after receiving an indication that the last man is leaving the trunk or 1 minute after the elapsed bottom time has expired, the upper access hatch is shut from inside the submarine using the remote hatch operating mechanism.
21. The trunk is vented and drained from inside the ship.
22. When the trunk is empty and the trunk pressure equals the pressure in the access compartment, the lower access hatch is opened for the next escape.
23. The rescue/escape trunk's flood, blow, vent, and drain cycles can be controlled from inside the access compartment, if necessary. See the applicable ship system manuals for more information.

SECTION 5.**SUBMARINE ESCAPE TRAINING****594-5.1 SUBMARINE SCHOOL**

594-5.1.1 GENERAL. The submarine escape appliance is so simple in design and operation that its proper use can be mastered with minimal formal training. Initial training is provided at Basic Submarine School. Classroom lecture is used to familiarize trainees with the escape appliance, the Submarine Rescue Chamber and Deep Sub-

mergence Rescue Vehicle, the physiological effects of escape, and the arrangement of a typical rescue/escape trunk using a mock-up. A training facility consisting of a rescue/escape trunk and swimming pool is used to familiarize trainees with the operation of the escape appliance and a typical rescue/escape trunk. The facility is also used to teach proper ascent and surface survival techniques.

594-5.2 ONBOARD SUBMARINE TRAINING

594-5.2.1 GENERAL. Initial training on board a submarine involves a hands-on overview of the operation of the submarine rescue/escape trunks and the submarine escape appliance. In addition, a training video entitled "Safe Submarine Escape" is viewed. The video is approximately 16 minutes long. It is unclassified and can be ordered by contacting the following:

Commander, Submarine Group 2
Code N74
Submarine On Board Training

Ask for Submarine On Board Training (SOBT) video number 5. The video discusses proper rescue/escape trunk operation, proper use of the submarine escape appliance, and provides general information concerning escape operations. Watching this video satisfies the requirement that all submarine crews participate in annual submarine escape training.

REAR SECTION

NOTE

TECHNICAL MANUAL DEFICIENCY/EVALUATION EVALUATION REPORT (TMDER) Forms can be found at the bottom of the CD list of books. Click on the TMDER form to display the form.

