



DEPARTMENT OF THE NAVY

NAVAL SEA SYSTEMS COMMAND
2531 JEFFERSON DAVIS HWY
ARLINGTON VA 22242-5160

11420 IN REPLY REFER TO
Ser 04XQ2/156
22 Dec 00

From: Commander, Naval Sea Systems Command

Subj: ADVANCE CHANGE NOTICE 1 TO NSTM CHAPTER 997

Ref: (a) Naval Ships' Technical Manual, NAVSEA S9086-7G-STM-010/CH-997R3
of 25 Nov 1996

Encl: (1) Figure 997-I-7. Individually Stacked Timber Keel Blocks and Cribbing

1. The purpose of this letter is to distribute Advance Change Notice 1 to reference (a).
2. Paragraph 997-2.5 and appendix I of reference (a) specify the technical considerations including longitudinal cribbing requirements for standard Navy docking blocks with longitudinal dimensions of 42 inches for keel blocks and 24 inches for side blocks. A recent incident on a marine railway found that 12x12 timber keel blocks were stacked individually and that the aft portion of the blocking was too high with no longitudinal cribbing installed in accordance with accepted practice. Recent observation of a ship transfer on a land level building way also found that long slender ship supports were used aft of the skag under the stern overhang without longitudinal bracing. The supports did not remain plumb during the transfer and their effectiveness was questionable.

3. Paragraph 2.5 is revised to add the following:

997-2.5.7 STABILITY OF SLENDER DOCKING BLOCKS. Many facilities such as marine railways and ship land level transfer systems use docking blocks that are not made from the standard Navy composite docking block as shown in Figure 997-I-L. Drydocking or transferring Navy ships on slender blocks results in problems in ensuring the column stability of the individual blocks and blocking system,

- a. The aspect ratio for uncribbed keel blocks shall not exceed 2.0 where the aspect ratio is defined as the block height divided by the horizontal dimension for the longitudinal and transverse directions, each checked separately. Where the longitudinal aspect ratio exceeds 2.0, cribbing shall be provided at an interval that does not exceed twice the longitudinal dimension of the blocking. Where the transverse aspect ratio exceeds 2.8, the blocking width shall be increased to a minimum of one half of the block height. For individually stacked 12x12 timber keel blocks, longitudinal cribbing shall be installed such that there are no more than two blocks stacked transversely between cribbing layers. Cribbing for individually stacked timber keel blocks shall be a minimum of 12 inches thick.

Subj: ADVANCE CHANGE NOTICE I TO NSTM CHAPTER 997

b. Side blocks with a longitudinal dimension less than 24 inches shall be longitudinally braced or cribbed when their height as measured from the base to the highest corner of the soft cap exceeds 3 times the longitudinal dimension. Bracing or cribbing shall be by an approved method.

c. Ship supports for land level transfer typically built on transfer strong-backs or support cradles shall be checked for column stability and for stability of stacked support elements such as steel tower structures and high timber blocking. Longitudinal cribbing or bracing shall be provided to ensure stability of supports and shall be by an approved method.

4. Appendix I is revised to add enclosure (I).

5. These changes to reference (a) are effective immediately.

6. Our point of contact is Mr. Rick Weiser (SEA 04XQ21), (703) 602-4222 X 220, DSN 332.

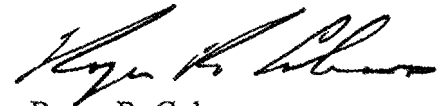

Roger R. Coleman
By direction

Distribution:

FKP7 NAVSHIPYDs

FKP8 SUPSHIPS

CINCLANTFLT

CINCPACFLT

COMSUBLANT

COMSURFLANT

COMSUBRON 2, 8, 11

COMSUBGRU 2

Navy Public Works Center San Diego

ARCO (ARDM-5)

DYNAMIC (AFDL-6)

OAK RIDGE (ARDM-1)

RESOLUTE (AFDM-10)

SHIPPINGPORT (ARDM-4)

SRF Yokosuka

NAVIMFAC PACNORWEST

TRIREFFAC Kings Bay

NFESC 62 Drydock Consultant

FIGURE 997-I-7. INDIVIDUALLY STACKED TIMBER KEEL BLOCKS AND CRIBBING

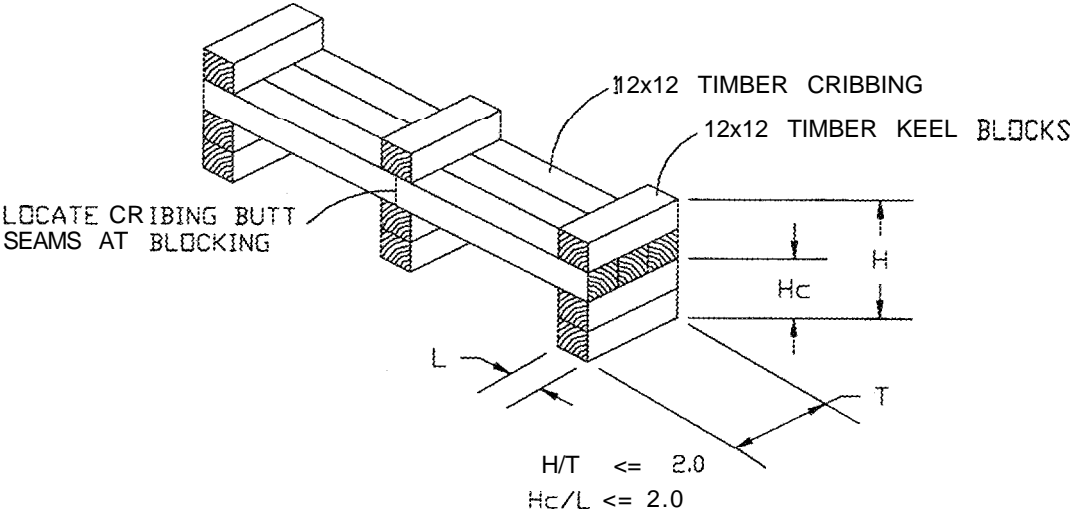

Blind copy to:

SEA 04X

04X1

04XQ2

04XQ2X (Charleston)

04X13D

File: General