

NAVAL SHIPS' TECHNICAL MANUAL

CHAPTER 542

GASOLINE AND JP-5 FUEL SYSTEMS

THIS CHAPTER SUPERSEDES CHAPTER 542 REVISION 4 DATED 15 JAN 2008.

DISTRIBUTION STATEMENT C: DISTRIBUTION AUTHORIZED TO U.S. GOVERNMENT AGENCIES AND THEIR CONTRACTORS; ADMINISTRATIVE AND OPERATIONAL USE (28 SEPTEMBER 1990). OTHER REQUESTS FOR THIS DOCUMENT BE REFERRED TO NSWC PHILADELPHIA, CODE 944.

WARNING: THIS DOCUMENT CONTAINS TECHNICAL DATA WHOSE EXPORT IS RESTRICTED BY THE ARMS EXPORT CONTROL ACT (TITLE 22, U.S.C. SEC 2751, ET SEQ.) OR THE EXPORT ADMINISTRATION ACT OF 1979, AS AMENDED, TITLE 50, U.S.C., APP 2401 ET SEQ. VIOLATIONS OF THESE EXPORT LAWS ARE SUBJECT TO SEVERE CRIMINAL PENALTIES. DISSEMINATE IN ACCORDANCE WITH PROVISIONS OF DOD DIRECTIVE 5230.25(D).

DESTRUCTION NOTICE: DESTROY BY ANY METHOD THAT WILL PREVENT DISCLOSURE OF CONTENTS OR RECONSTRUCTION OF THE DOCUMENT.

REVISION RECORD

REVISION NO.	DATE	TITLE AND/OR BRIEF DESCRIPTION/PREPARING ACTIVITY
4	15 JAN 2008	PARAGRAPH(S) 542-1.1.1, 542-1.2.9, 542-1.2.15, 542-1.2.16, 542-1.2.17, 542-1.2.18, 542-2.5.1.1, 542-2.5.1.2, 542-2.5.2.4, 542-2.7.2, 542-2.8.2, 542-3.1.1, 542-3.3.3.3, 542-3.3.5, 542-3.5.8, 542-3.6.6, 542-3.6.7, 542-3.8.3, 542-4.1.1.1, 542-4.1.5, 542-4.2.1, 542-4.2.1.1, 542-4.2.1.3, 542-4.2.1.4, 542-4.2.4.4.3, 542-4.3.1, 542-4.3.5.1, 542-4.3.6, 542-4.4.1.2, 542-4.8.3.1, 542-6.1.2, 542-6.5.1 AND 542-6.8.1 TABLE(S) 542-7-1.
5	1 JUL 2010	INCORPORATED TMDER N65540-09-DU13.CHANGE AUTHORIZED BY NSWCCD-SSES CODES 923 AND 944. THE FOLLOWING WAS CHANGED: PARAGRAPH(S) , 542-3.4.1.3, 542-4.2.4.5.2, 542-4.3.5.2, 542-4.3.5.5, 542-4.3.5.6, 542-4.4.5.2, 542-4.5.4, 542-4.5.5.2, 542-4.5.5.4, 542-4.5.5.6, 542-4.7.1, 542-4.8.2, 542-5.3.3, 542-6.2.4.1.2, 542-6.3.1, 542-6.3.2, 542-6.3.4.2, 542-6.3.6.1, 542-6.3.6.2, 542-6.3.6.2.1, 542-6.3.6.2.4, 542-6.3.6.3, 542-6.3.6.4, 542-6.3.7, 542-6.3.8.1, 542-6.5.4, 542-6.7.1, 542-6.8.1, 542-6.11.1, 542-6.11.2, 542-7.2.2, 542-7.2.3, 542-7.4.6, 542-7.4.6.2.2, 542-7.4.7 AND 542-7.5 TABLE(S) 542-6-2. AND 542-7-1. FIGURE(S) 542-6-6., 542-6-7., 542-6-8., 542-6-9., 542-6-10., 542-6-11., 542-6-12., 542-6-13., 542-6-14., 542-6-15., 542-6-16. AND 542-6-17.

TABLE OF CONTENTS

Chapter/Paragraph	Page
542 GASOLINE AND JP-5 FUEL SYSTEMS	1-1
SECTION 1 INTRODUCTION	1-1
542-1.1 SCOPE	1-1
542-1.2 DEFINITIONS	1-1
542-1.2.1 AUTOGENOUS IGNITION TEMPERATURE.	1-1
542-1.2.2 MICROBIOLOGICAL GROWTH.	1-1
542-1.2.3 CLEAR AND BRIGHT.	1-1
542-1.2.4 COFFERDAM.	1-1
542-1.2.5 CONTAMINATION.	1-1
542-1.2.6 DISSOLVED WATER.	1-1
542-1.2.7 EMULSION.	1-1
542-1.2.8 EXISTENT GUM.	1-1
542-1.2.9 NAVAL DISTILLATE FUEL.	1-2
542-1.2.10 FLASH POINT.	1-2
542-1.2.11 FREE WATER.	1-2
542-1.2.12 FSIL.	1-2
542-1.2.13 HYDROCARBON.	1-2
542-1.2.14 INERT GAS.	1-2
542-1.2.15 JP-4.	1-2
542-1.2.16 JP-5.	1-2
542-1.2.17 JP-8.	1-2
542-1.2.18 MOGAS.	1-2
542-1.2.19 OCTANE NUMBER.	1-3
542-1.2.20 PARTICULATE MATTER.	1-3
542-1.2.21 POL.	1-3
542-1.2.22 REID VAPOR PRESSURE TEST (RVP).	1-3
542-1.2.23 SURFACTANT.	1-3
542-1.2.24 TETRAETHYL LEAD (TEL).	1-3
542-1.2.25 VOLATILITY.	1-3
542-1.2.26 PQS.	1-3
542-1.3 FUEL DESCRIPTIONS	1-3
542-1.3.1 MOGAS DESCRIPTION.	1-3
542-1.3.2 JP-5 DESCRIPTION.	1-4
542-1.4 FUEL CHARACTERISTICS	1-4
542-1.4.1 MOGAS.	1-4
542-1.4.1.1 Unwashed Gum.	1-4
542-1.4.1.2 Summer and Winter Gas.	1-4
542-1.4.2 JP-5.	1-4
542-1.5 REFERENCE INFORMATION	1-5
542-1.5.1 CHAPTERS IN THE NAVAL SHIPS' TECHNICAL MANUAL.	1-5

TABLE OF CONTENTS - Continued

Chapter/Paragraph	Page
542-1.5.2 SHIP INFORMATION BOOK (SIB).	1-5
542-1.5.3 TECHNICAL MANUALS.	1-5
542-1.5.4 BULLETINS AND INSTRUCTIONS.	1-6
542-1.5.5 AVIATION FUEL OPERATIONAL SEQUENCING SYSTEM (AFOSS). . .	1-6
542-1.5.6 CARGO FUEL OPERATIONAL SEQUENCING SYSTEM (CFOSS). . . .	1-6
SECTION 2 SAFETY	2-1
542-2.1 RESPONSIBILITY OF COMMANDING OFFICERS	2-1
542-2.2 HAZARDS OF HANDLING GASOLINE	2-1
542-2.2.1 EXPLOSIVE MIXTURES OF GASOLINE AND AIR.	2-1
542-2.2.2 HIGH PRESSURE AND TEMPERATURE.	2-1
542-2.2.3 PERSONNEL HAZARDS.	2-1
542-2.3 HAZARDS OF HANDLING JP-5	2-1
542-2.3.1 FIRE HAZARD FROM HIGH TEMPERATURE OR WICKING.	2-1
542-2.3.2 PERSONNEL HAZARDS.	2-2
542-2.4 PRECAUTIONS FOR GASOLINE AND JP-5	2-2
542-2.4.1 PERSONNEL PROTECTION.	2-2
542-2.4.2 ENTRY INTO FUEL TANKS.	2-2
542-2.4.3 FILTER SEPARATOR ELEMENT REPLACEMENT.	2-2
542-2.4.4 SLUDGE DISPOSAL.	2-3
542-2.4.5 SPRAY-SHIELDED FLANGED CONNECTIONS.	2-3
542-2.4.6 JOINTS AND LEAKS.	2-3
542-2.4.7 USE OF PORTABLE ELECTRIC EQUIPMENT NEAR FUEL.	2-3
542-2.4.8 HOT WORK NEAR GASOLINE AND JP-5.	2-3
542-2.5 SPECIAL PRECAUTIONS FOR GASOLINE	2-3
542-2.5.1 RECEIVING, STORING, AND DISCHARGING GASOLINE.	2-3
542-2.5.1.1 Bulk Gasoline.	2-3
542-2.5.1.2 Containerized Gasoline (All Types).	2-4
542-2.5.2 GASOLINE HAZARD AREAS.	2-4
542-2.5.2.1 Designation of Gasoline Hazard Areas.	2-4
542-2.5.2.2 Warning Plate for Gasoline Hazard Areas.	2-5
542-2.5.2.3 Ventilation Requirements For Gasoline Hazard Areas.	2-5
542-2.5.2.4 Breathing Protection in Gasoline Pump Rooms.	2-5
542-2.5.2.5 Internal Ship Portable Gasoline Movement.	2-5
542-2.5.3 WARNING PLATES FOR ELECTRIC MOTOR-DRIVEN GASOLINE PUMPS.	2-5
542-2.6 FUELING	2-6
542-2.6.1 FUELING AIRCRAFT WITH JP-5.	2-6
542-2.6.2 HELICOPTER INFLIGHT REFUELING WITH JP-5.	2-6
542-2.6.3 SHIPBOARD HANDLING OF AIRCRAFT FUEL	2-7
542-2.6.3.1 AIRCRAFT WASTE FUEL DRAIN.	2-7

TABLE OF CONTENTS - Continued

Chapter/Paragraph	Page
542-2.6.4 FUELING VEHICLES AND PORTABLE CONTAINERS WITH GASOLINE.	2-7
542-2.7 FIRE PROTECTION	2-7
542-2.7.1 FIREFIGHTING REFERENCES.	2-7
542-2.7.2 CLASS B FIRES (FLAMMABLE LIQUIDS).	2-8
542-2.8 APPARATUS FOR TESTING ATMOSPHERE NEAR FUEL	2-8
542-2.8.1 PORTABLE INERTNESS ANALYZER.	2-8
542-2.8.1.1 Description.	2-8
542-2.8.1.2 Principles of Operation.	2-9
542-2.8.1.3 Operating Procedures.	2-9
542-2.8.1.4 Maintenance.	2-10
542-2.8.1.5 Calibration.	2-10
542-2.8.2 COMBUSTIBLE GAS INDICATOR.	2-10
542-2.8.3 OXYGEN INDICATOR.	2-10
542-2.9 PRECAUTIONS FOR FLEET OILERS	2-11
542-2.10 HARBOR POLLUTION	2-13
SECTION 3 MOGAS SYSTEMS	3-1
542-3.1 INTRODUCTION	3-1
542-3.2 MOGAS STORAGE	3-1
542-3.2.1 STORAGE TANK COMPENSATING SYSTEMS.	3-1
542-3.2.1.1 Seawater Compensated Storage.	3-1
542-3.2.1.2 Inert Gas Compensated Storage.	3-3
542-3.2.1.3 GASOLINE TANK EXTERNAL PROTECTION.	3-4
542-3.2.1.3.1 Nitrogen Inerting of Cofferdams and Piping.	3-4
542-3.2.1.3.2 CO ₂ Inerting of Cofferdams and Piping.	3-4
542-3.2.2 Portable Containers	3-5
542-3.3 MOGAS SYSTEM COMPONENTS	3-5
542-3.3.1 GASOLINE STORAGE TANKS.	3-5
542-3.3.1.1 Tank Coating.	3-5
542-3.3.1.2 Tank Venting.	3-5
542-3.3.1.3 Tank-Top Pressure Indicators.	3-5
542-3.3.1.4 Tank Level Indicating System.	3-6
542-3.3.1.5 Tank Sluice Piping and Diffuser.	3-6
542-3.3.2 PUMPS.	3-6
542-3.3.3 VEHICLE FUELING STATION.	3-7
542-3.3.3.1 CLA-VAL Type Station.	3-7
542-3.3.3.2 Manual Type Station.	3-7
542-3.3.3.3 Pressure-Regulating Type Station.	3-7

TABLE OF CONTENTS - Continued

Chapter/Paragraph	Page	
542-3.3.3.3.1	MOGAS Ready Service Station/Bladder	
	Stowage	3-7
542-3.3.4	GASOLINE FILTER SEPARATOR.	3-7
542-3.3.5	MOGAS Detection Systems	3-7
542-3.4	MOGAS SYSTEM PIPING REQUIREMENTS	3-8
542-3.4.1	GENERAL.	3-8
542-3.4.2	TANK FILLING AND DISTRIBUTION PIPING.	3-8
542-3.4.3	PRESSURE-REGULATING AND VENTURI PIPING.	3-8
542-3.4.4	PUMP AND VENTURI RECIRCULATING PIPING.	3-9
542-3.4.5	INERT GAS SYSTEM PIPING.	3-9
542-3.5	BASIC MOGAS OPERATIONS	3-9
542-3.5.1	CFOSS AND SAFETY INFORMATION.	3-9
542-3.5.2	PRE-OPERATING FIRE SAFETY CHECK.	3-9
542-3.5.3	FILLING SEAWATER COMPENSATED TANKS WITH SEAWATER.	3-9
542-3.5.4	FILLING SEAWATER EXPANSION TANKS WITH SEAWATER.	3-10
542-3.5.5	OPERATING SEAWATER SYSTEM TO PRIME GASOLINE PUMPS.	3-10
542-3.5.6	RECEIVING GASOLINE.	3-11
542-3.5.6.1	Receiving into Seawater Compensated Systems in an Empty Condition	3-11
542-3.5.6.2	Initial Receiving in CO ₂ Compensated Systems In an Empty Condition.	3-12
542-3.5.6.3	Subsequent Receiving in Seawater Compensated Systems.	3-12
542-3.5.6.4	Subsequent Receiving in CO ₂ Compensated Systems.	3-12
542-3.5.7	PREPARATION FOR FUELING VEHICLES.	3-12
542-3.5.8	PROCEDURE FOR FUELING VEHICLES.	3-13
542-3.5.9	DELIVERING GASOLINE OFF-SHIP.	3-14
542-3.5.10	DRAINING AND SECURING SYSTEM.	3-15
542-3.6	OTHER MOGAS OPERATIONS	3-15
542-3.6.1	FLUSHING THE WATER COMPENSATED STORAGE TANK.	3-15
542-3.6.2	EMPTYING OF STORAGE TANKS.	3-15
542-3.6.3	STEAMING OUT.	3-17
542-3.6.4	STRIPPING THE DRAWOFF TANK.	3-17
542-3.6.5	STRIPPING CO ₂ COMPENSATED TANKS.	3-17
542-3.6.6	USING TANK LEVEL INDICATING SYSTEM.	3-17
542-3.6.7	DRAINAGE OF COFFERDAM AND PUMPROOM.	3-18
542-3.7	TROUBLESHOOTING	3-18
542-3.7.1	WATER IN THE MOGAS SYSTEM.	3-18
542-3.7.2	MALFUNCTION OF GASOLINE TANK LEVEL INDICATORS.	3-19
542-3.7.3	PUMP CAVITATION.	3-19
542-3.7.4	FUELING STATION PRESSURE PROBLEM.	3-19
542-3.8	MOGAS SYSTEM MAINTENANCE	3-19
542-3.8.1	TOOLS.	3-19

TABLE OF CONTENTS - Continued

Chapter/Paragraph	Page
542-3.8.2	FILTER ELEMENTS. 3-19
542-3.8.3	COFFERDAM AND DOUBLE-WALL PIPE INERTING. 3-19
542-3.8.4	HOUSEKEEPING. 3-20
542-3.8.5	MOGAS FUEL SAMPLING AND TESTING. 3-20
542-3.9	MOGAS SYSTEM PRESSURE TESTING 3-20
542-3.9.1	GENERAL. 3-20
542-3.9.2	AIR AND SF6 REFRIGERANT TEST OF STORAGE TANKS. 3-20
542-3.9.3	HYDROSTATIC TEST OF STORAGE TANKS. 3-20
542-3.9.4	HYDROSTATIC TEST OF MOGAS AND SEAWATER PIPING. 3-20
542-3.9.5	AIR AND SF6 TEST OF MOGAS AND SEAWATER PIPING. 3-20
542-3.9.6	DRY CLEANING SOLVENT OR JP-5 HYDROSTATIC TEST OF MOGAS PIPING. 3-21
542-3.9.7	OPERATIONAL TEST OF MOGAS SYSTEM. 3-21
542-3.9.8	STORAGE TANK FLUSH. 3-21
542-3.9.9	ADDITIONAL TESTING INFORMATION. 3-21
SECTION 4	JP-5 SYSTEMS (AVIATION AND AIR CAPABLE TYPE SHIPS) 4-1
542-4.1	PRINCIPLES OF JP-5 SYSTEMS 4-1
542-4.1.1	SHIP TYPE. 4-1
542-4.1.1.1	Aviation Type Ships. 4-1
542-4.1.1.2	Air Capable Type Ships. 4-1
542-4.1.1.3	JP-5. 4-1
542-4.1.2	JP-5 SYSTEM PRIMARY FUNCTION. 4-1
542-4.1.3	OTHER JET FUELS PROHIBITED IN JP-5 SYSTEMS. 4-1
542-4.1.3.1	Aviation Turbine Fuel Thermal Stability Additive 4-1
542-4.1.4	JP-5 SYSTEMS. 4-2
542-4.2	AVIATION SHIP JP-5 SYSTEM DESCRIPTION 4-3
542-4.2.1	JP-5 TANKS. 4-3
542-4.2.1.1	JP-5 Tank Overflows. 4-3
542-4.2.1.2	JP-5 Tank Sounding Tubes and Air Escape Piping. 4-3
542-4.2.1.3	JP-5 Tank Level Indicators. 4-3
542-4.2.1.4	JP-5 Tank Level Alarms. 4-4
542-4.2.1.5	JP-5 Tank Coating. 4-4
542-4.2.1.6	JP-5 Tank Cleaning. 4-4
542-4.2.2	AVIATION SHIP JP-5 STRIPPING SYSTEM. 4-5
542-4.2.2.1	Motorized Pump Stripping for Storage Tanks. 4-5
542-4.2.2.2	Stripping Systems for Service Tanks. 4-5
542-4.2.3	AVIATION SHIP JP-5 FILLING AND TRANSFER SYSTEM. 4-5
542-4.2.3.1	Fueling-at-Sea (FAS) Connections. 4-5
542-4.2.3.2	JP-5 Transfer Pumps. 4-6
542-4.2.3.3	JP-5 Transfer Filter Separator. 4-6
542-4.2.3.4	JP-5 Purifiers. 4-6
542-4.2.4	AVIATION SHIP JP-5 SERVICE SYSTEM. 4-6
542-4.2.4.1	JP-5 Service Tanks. 4-6

TABLE OF CONTENTS - Continued

Chapter/Paragraph	Page
542-4.2.4.2 JP-5 Service Pumps.	4-6
542-4.2.4.3 JP-5 Service Filter Separator.	4-6
542-4.2.4.4 JP-5 Service System Piping.	4-6
542-4.2.4.5 JP-5 Fueling Station.	4-7
542-4.2.5 AVIATION SHIP JP-5 BALLAST SYSTEM.	4-8
542-4.2.6 AVIATION SHIP JP-5 AUXILIARY SERVICE SYSTEM.	4-8
542-4.2.7 AVIATION SHIP JP-5 JET ENGINE TEST SYSTEM.	4-8
542-4.2.8 AVIATION SHIP JP-5 RECLAMATION SYSTEM.	4-8
542-4.3 AVIATION SHIP JP-5 OPERATIONS	4-8
542-4.3.1 AFOSS AND SAFETY INFORMATION.	4-8
542-4.3.2 RECEIVING JP-5 ON AVIATION SHIPS.	4-9
542-4.3.3 AVIATION SHIP JP-5 STORAGE PROCEDURES.	4-10
542-4.3.3.1 Stripping of JP-5 Storage Tanks.	4-10
542-4.3.3.2 Ballasting and Deballasting JP-5 Storage or Ballast Tanks.	4-10
542-4.3.4 AVIATION SHIP JP-5 TRANSFER SYSTEM OPERATION.	4-11
542-4.3.4.1 Consolidation and Settling.	4-11
542-4.3.4.2 Emergency JP-5 Fuel to Boilers.	4-11
542-4.3.4.3 Replenishing Ships in Company.	4-12
542-4.3.5 AVIATION SHIP JP-5 SERVICE SYSTEM OPERATION.	4-12
542-4.3.5.1 Service System Startup.	4-12
542-4.3.5.2 Service System General Operating Information.	4-12
542-4.3.5.3 JP-5 Fueling Station Operation.	4-13
542-4.3.5.4 Preparations for JP-5 Fueling and Defueling of Aircraft with Engines Off.	4-13
542-4.3.5.5 JP-5 Fueling.	4-14
542-4.3.5.6 Refueling of Aircraft with Engines Operating (Hot Refueling).	4-15
542-4.3.5.7 Defueling JP-5.	4-16
542-4.3.6 AVIATION SHIP AUXILIARY SERVICE JP-5 SYSTEM.	4-17
542-4.3.7 DELIVERING JP-5 OFF-SHIP.	4-17
542-4.4 AIR CAPABLE SHIP AVIATION JP-5 SYSTEM DESCRIPTIONS	4-18
542-4.4.1 INTRODUCTION.	4-18
542-4.4.1.1 System Functions.	4-18
542-4.4.1.2 JP-5 Tanks and Tank Level Indicators.	4-18
542-4.4.2 AIR CAPABLE SHIP JP-5 RECEIVING SYSTEM.	4-18
542-4.4.3 AIR CAPABLE SHIP JP-5 STRIPPING SYSTEM.	4-19
542-4.4.4 AIR CAPABLE SHIP JP-5 TRANSFER SYSTEM.	4-19
542-4.4.5 AIR CAPABLE SHIP JP-5 SERVICE SYSTEM.	4-19
542-4.4.5.1 Helicopter In-flight Refueling System.	4-19
542-4.4.5.2 Helicopter Fueling Station.	4-19
542-4.4.5.3 Helicopter Defueling System.	4-20
542-4.5 AIR CAPABLE SHIP JP-5 SYSTEM OPERATIONS	4-20
542-4.5.1 OPERATIONAL PROCEDURES AND SAFETY INFORMATION.	4-20
542-4.5.2 RECEIVING JP-5 ON AIR CAPABLE SHIPS.	4-21
542-4.5.3 JP-5 STRIPPING ON AIR CAPABLE SHIPS.	4-21

TABLE OF CONTENTS - Continued

Chapter/Paragraph	Page
542-4.5.4 AIR CAPABLE SHIP JP-5 TRANSFER SYSTEM OPERATION.	4-21
542-4.5.5 AIR CAPABLE SHIP JP-5 SERVICE SYSTEM OPERATION.	4-22
542-4.5.5.1 Service System Startup.	4-22
542-4.5.5.2 Service System General Operating Information.	4-22
542-4.5.5.3 Fueling and Defueling Preparations for Helicopters.	4-22
542-4.5.5.4 On-Deck Helicopter Fueling.	4-23
542-4.5.5.5 On-Deck Refueling of Helicopters with Engines Operating (Hot Refueling).	4-25
542-4.5.5.6 HIFR Preparations.	4-26
542-4.5.5.7 HIFR Procedure.	4-28
542-4.5.5.8 Helicopter Defueling.	4-29
542-4.6 JP-5 SYSTEM TROUBLESHOOTING (AVIATION SHIPS AND AIR CAPABLE SHIPS)	4-30
542-4.6.1 JP-5 PUMP FAILS TO TAKE SUCTION.	4-30
542-4.6.2 MALFUNCTIONS OF JP-5 TANK LEVEL INDICATORS.	4-30
542-4.6.3 WATER IN JP-5 SYSTEM.	4-30
542-4.6.4 MICROBIOLOGICAL GROWTH IN JP-5.	4-30
542-4.6.5 FAILURE OF JP-5 FUELING STATION SOLENOID VALVE.	4-31
542-4.6.6 HELICOPTER FUEL TANK OVERPRESSURIZATION.	4-33
542-4.7 JP-5 SYSTEM MAINTENANCE (AVIATION SHIPS AND AIR CAPABLE SHIPS)	4-33
542-4.7.1 JP-5 FILTER SEPARATOR MAINTENANCE.	4-33
542-4.7.2 JP-5 TANK INSPECTION AND CLEANING.	4-34
542-4.7.3 JP-5 TESTS AND SAMPLING INSTRUCTIONS.	4-34
542-4.8 JP-5 SYSTEM PRESSURE TESTING (AVIATION AND AIR CAPABLE SHIPS) .	4-34
542-4.8.1 GENERAL.	4-34
542-4.8.2 SYSTEM FLUSH.	4-34
542-4.8.2.1 Air Testing.	4-34
542-4.8.3 HYDROSTATIC TEST OF PIPING.	4-34
542-4.8.4 OPERATIONAL TEST.	4-35
542-4.8.5 ADDITIONAL TESTING INFORMATION.	4-35
SECTION 5 FLEET OILERS	5-1
542-5.1 INTRODUCTION	5-1
542-5.2 CARGO JP-5 SYSTEM	5-1
542-5.2.1 RECEIVING JP-5 ON OILERS.	5-1
542-5.2.2 TRANSFERRING AND OFF-LOADING CARGO JP-5.	5-2
542-5.2.3 CARGO JP-5 STRIPPING PROCEDURES.	5-2
542-5.2.4 BALLASTING OPERATION.	5-3
542-5.2.5 SHORE TANK VS. SHIP TANK GAGING DISCREPANCIES.	5-3
542-5.2.6 PIPING SYSTEMS.	5-3

TABLE OF CONTENTS - Continued

Chapter/Paragraph	Page
542-5.3 CARGO JP-5 FUEL QUALITY	5-3
542-5.3.1 CONTAMINATION.	5-3
542-5.3.1.1 Investigation of Suspected Contamination.	5-3
542-5.3.1.2 Procedure for Reporting Contamination.	5-4
542-5.3.2 TANK CLEANING.	5-4
542-5.3.3 FUEL QUALITY TESTS.	5-5
SECTION 6 MOGAS AND JP-5 SYSTEM COMPONENTS	6-1
542-6.1 PUMPS	6-1
542-6.1.1 MOGAS SYSTEM PUMPS.	6-1
542-6.1.2 JP-5 SYSTEM PUMPS.	6-1
542-6.1.3 PUMP OPERATION.	6-1
542-6.1.4 PUMP SAFETY.	6-2
542-6.1.5 PUMP MAINTENANCE.	6-2
542-6.1.6 PUMP TROUBLESHOOTING.	6-2
542-6.2 FILTER SEPARATOR FOR MOGAS AND JP-5 SYSTEMS	6-2
542-6.2.1 FUNCTIONAL DESCRIPTION.	6-2
542-6.2.2 FILTER SEPARATOR CONSTRUCTION.	6-3
542-6.2.3 FILTER SEPARATOR OPERATION.	6-5
542-6.2.4 FILTER SEPARATOR MAINTENANCE.	6-5
542-6.2.4.1 Filter Separator Maintenance Intervals.	6-5
542-6.2.4.2 Coalescer Element Removal Procedure.	6-6
542-6.2.4.3 Coalescer Element Inspection and Replacement.	6-7
542-6.2.4.4 Separator Element Replacement and Test.	6-7
542-6.2.5 ORDERING FILTER SEPARATOR ELEMENTS.	6-9
542-6.2.6 FILTER SEPARATOR TROUBLESHOOTING GUIDE.	6-9
542-6.2.6.1 Contaminated Fuel at Service Station.	6-9
542-6.2.6.2 Incorrect Pressure at Fueling Stations.	6-10
542-6.3 HOSE, HOSE REELS, AND NOZZLES	6-10
542-6.3.1 HOSE DESCRIPTION AND TYPES.	6-10
542-6.3.2 PREPARING JP-5 FUELING HOSE FOR USE.	6-16
542-6.3.3 JP-5 FUELING HOSE OPERATING PRECAUTIONS.	6-16
542-6.3.4 HOSE INSPECTION AND MAINTENANCE.	6-16
542-6.3.5 HOSE REELS.	6-18
542-6.3.6 FUELING NOZZLES.	6-18
542-6.3.6.1 Gravity Fueling Nozzle.	6-18
542-6.3.6.2 D-1 and D-1R Pressure Fueling Nozzle.	6-20
542-6.3.6.3 OPW Gravity Nozzle.	6-24
542-6.3.6.4 CCR Nozzle.	6-26
542-6.3.7 HOSE END PRESSURE CONTROL VALVE.	6-26
542-6.3.8 UNISEX COUPLINGS.	6-26
542-6.4 FUELING-AT-SEA RIGS	6-27
542-6.4.1 GENERAL.	6-27

TABLE OF CONTENTS - Continued

Chapter/Paragraph		Page
542-6.4.2	PROBE AND RECEIVER.	6-28
542-6.4.3	QUICK-RELEASE COUPLING WITH BREAKABLE SPOOL.	6-28
542-6.4.4	COMBINED QUICK-RELEASE COUPLING AND VALVE (ROBB COUPLING).	6-28
542-6.4.5	SAFETY PRECAUTIONS.	6-28
542-6.4.6	BLOWDOWN OF THE HOSE.	6-28
542-6.5	AVIATION SHIP JP-5 PURIFIERS	6-28
542-6.5.1	GENERAL INFORMATION.	6-28
542-6.5.2	PURIFIER DESCRIPTION.	6-28
542-6.5.3	PURIFIER AUTOMATIC SHUTOFF.	6-29
542-6.5.4	PURIFIER PRINCIPLES OF OPERATION.	6-29
542-6.5.5	PURIFIER OPERATING PRECAUTIONS.	6-29
542-6.5.6	PLACING THE PURIFIER IN STANDBY.	6-30
542-6.5.7	PURIFIER MAINTENANCE.	6-31
542-6.5.8	PURIFIER TROUBLESHOOTING.	6-31
542-6.6	TANK LEVEL INDICATING SYSTEMS	6-32
542-6.6.1	TYPES.	6-32
542-6.6.2	DESCRIPTIONS OF STATIC HEAD TANK LEVEL INDICATORS.	6-32
542-6.6.3	DESCRIPTION OF MF ELECTRICAL TYPE SYSTEM.	6-33
542-6.6.4	Description of Sounding Tube Pulse Radar Systems.	6-33
542-6.6.5	TLI OPERATION.	6-33
542-6.6.6	TLI MAINTENANCE.	6-33
542-6.7	MOGAS SYSTEM PRESSURE VALVE AND VENTURI	6-33
542-6.8	AUTOMATIC CLA-VAL FUEL-DEFUEL VALVE	6-34
542-6.9	AIR ELIMINATOR VALVE	6-36
542-6.10	MOGAS SYSTEM EDUCTORS	6-37
542-6.10.1	PORTABLE EDUCTORS.	6-37
542-6.10.2	FIXED EDUCTORS.	6-37
542-6.10.3	EDUCTOR OPERATION.	6-37
542-6.10.4	EDUCTOR MAINTENANCE.	6-37
542-6.11	CENTRAL CONTROL AND MONITORING OF JP-5 SYSTEMS	6-37
542-6.11.1	GENERAL INFORMATION.	6-37
542-6.11.2	CONSOLE CONTROLS AND INDICATORS.	6-37
542-6.11.3	JP-5 SYSTEM VALVES.	6-38
542-6.12	Aircraft-to-Aircraft Transfer Cart.	6-38
542-6.13	Portable Defuel Cart.	6-39
SECTION 7	FUEL QUALITY MANAGEMENT	7-1

TABLE OF CONTENTS - Continued

Chapter/Paragraph	Page
542-7.1 INTRODUCTION	7-1
542-7.2 FUEL QUALITY	7-3
542-7.2.1 VISUAL CRITERIA.	7-3
542-7.2.2 SOLIDS CONTAMINATION.	7-3
542-7.2.3 FREE WATER CONTAMINATION.	7-3
542-7.2.4 FUEL SYSTEM ICING INHIBITOR.	7-3
542-7.2.5 FLASH POINT.	7-4
542-7.2.6 ROLE OF FILTER SEPARATOR OR PURIFIERS.	7-4
542-7.3 SAMPLING	7-4
542-7.3.1 SAMPLE REQUIREMENTS.	7-4
542-7.3.2 SAMPLES FOR FUEL LABS.	7-4
542-7.3.3 SAMPLE CONTAINERS.	7-6
542-7.3.4 SAMPLE LABEL.	7-6
542-7.3.5 AVIATION FUEL SAMPLE LOG.	7-7
542-7.4 SHIPBOARD FUEL TESTING	7-7
542-7.4.1 APPLICATION OF FUEL TEST APPARATUS.	7-7
542-7.4.2 CONTAMINATED FUEL DETECTOR.	7-7
542-7.4.2.1 Principles of Operation.	7-7
542-7.4.2.2 CFD/CCFD Typical Operating Instructions.	7-8
542-7.4.2.3 Use of the CFD/CCFD.	7-9
542-7.4.3 FREE WATER DETECTOR.	7-9
542-7.4.3.1 Principles of Operation.	7-10
542-7.4.3.2 Free Water Detector Operating Instructions.	7-10
542-7.4.4 COMBINED CONTAMINATED FUEL DETECTOR.	7-11
542-7.4.5 FSII TEST KIT.	7-11
542-7.4.5.1 Principles of Operation.	7-11
542-7.4.5.2 Operating Instructions.	7-11
542-7.4.6 FLASH POINT TEST PROCEDURES.	7-11
542-7.4.6.1 Pensky-Martens Method.	7-12
542-7.4.6.2 NAVIFLASH Method	7-13
542-7.4.7 In-Line Fuel Quality Sensor.	7-14
542-7.5 TEST RESULT ACTION	7-15
542-7.6 JP-5 TANK STRIPPING	7-15
542-7.6.1 STRIPPING SYSTEMS.	7-15
542-7.6.2 STORAGE TANK STRIPPING.	7-15
542-7.6.3 SERVICE TANK STRIPPING.	7-16
542-7.7 MAINTENANCE	7-16
A Technical Manual Deficiency/Evaluation Report(TMDER)	3-5

LIST OF TABLES

Table	Title	Page
542-4-1.	AVIATION SHIP BASIC JP-5 OPERATIONS	4-9
542-4-2.	AIR CAPABLE SHIP BASIC JP-5 OPERATIONS	4-20
542-6-1.	ORDERING FILTER SEPARATOR ELEMENTS	6-9
542-6-2.	ORDERING FUELING HOSTS AND HOSE END FITTINGS	6-13
542-6-3.	ORDERING FUELING HOSE ACCESSORIES	6-13
542-7-1.	FUEL SAMPLING REQUIREMENTS	7-1
542-7-2.	FUEL TESTING LABORATORIES	7-5
542-7-3.	STOCK NUMBERS FOR FUEL SAMPLING KITS	7-6

LIST OF ILLUSTRATIONS

Figure	Title	Page
542-2-1.	Portable Inertness Analyzer	2-8
542-3-1.	U-Tube Analogy (Seawater Compensated [Hydraulic] Gasoline Storage)	3-2
542-3-2.	Seawater Compensated Gasoline Storage Tank	3-3
542-4-1.	Helicopter On-Deck Fueling and Flushing	4-24
542-4-2.	Helicopter Inflight Fueling and Flushing	4-27
542-4-3.	Hose Reel Fluid Path with Control Wire	4-32
542-6-1.	Filter Separator (Flow Schematic)	6-3
542-6-2.	Filter Separator	6-4
542-6-3.	Filter Element Mounting Assembly	6-5
542-6-4.	Fueling Hose with Control Wire Assembly	6-11
542-6-5.	Fueling Nozzle and Hose Arrangements	6-12
542-6-6.	JP5 Auxillary Fuel Hose Adapter	6-15
542-6-7.	Fueling Nozzle and Hose Arrangements	6-17
542-6-8.	Gravity Fueling Nozzle	6-19
542-6-9.	Pressure Fueling Nozzle	6-21
542-6-10.	D-1R Pressure Fueling Nozzle (with HEPCV)	6-23
542-6-11.	OPW Gravity Nozzle	6-25
542-6-12.	Closed-Circuit Refueling (CCR) Nozzle	6-26
542-6-13.	Unisex Coupling	6-27
542-6-14.	Flow and Operation of Purifier (B-214) Bowl	6-29
542-6-15.	Pressure Regulating System Schematic	6-34
542-6-16.	CLA-VAL Fuel-Defuel Valve (Fueling Mode)	6-35
542-6-17.	CLA-VAL Fuel-Defuel Valve (Defueling Mode)	6-36

CHAPTER 542

GASOLINE AND JP-5 FUEL SYSTEMS

SECTION 1

INTRODUCTION

542-1.1 SCOPE

542-1.1.1 This NSTM chapter contains descriptions, safety precautions, maintenance and testing information, troubleshooting guidance, and operating requirements for shipboard automotive gasoline (MOGAS) and aviation JP-5 Fuel systems. There are no dedicated ship systems for the storage or handling of aviation gasoline (AVGAS).

542-1.2 DEFINITIONS

542-1.2.1 AUTOGENOUS IGNITION TEMPERATURE. The temperature just adequate to cause the vapors from a petroleum product to burst into flames without the application of a spark or flame.

542-1.2.2 MICROBIOLOGICAL GROWTH. Living organisms such as fungi and bacteria. These organisms will grow at a fuel-water interface.

542-1.2.3 CLEAR AND BRIGHT. Clear means the absence of any cloud, emulsion, or readily visible particulate matter. Bright refers to the shiny appearance of clean, dry fuels.

542-1.2.4 COFFERDAM. A protective space or shell surrounding a gasoline storage tank and filled with an inert gas such as nitrogen or carbon dioxide.

542-1.2.5 CONTAMINATION. Contamination of a fuel is defined as the presence of foreign matter or other petroleum products, resulting in failure of the fuel to meet specifications or use limits.

542-1.2.6 DISSOLVED WATER. All fuels contain water in solution, but the amount varies according to the temperature. The colder the fuel, the less water it can hold in solution. This water cannot be separated by filtration or mechanical means.

542-1.2.7 EMULSION. A liquid suspended in another liquid. There are two common types of emulsion in fuel systems: water in fuel, and fuel in water. Water in fuel is the most common and appears as a light to heavy cloud in fuel. A fuel in water emulsion is reddish, grayish, or blackish in color and is very sticky or gummy, adhering to most materials with which it comes in contact.

542-1.2.8 EXISTENT GUM. Existent gum is the amount of nonvolatile residue present in the gasoline or aviation turbine fuel at the time of test. The results indicate the quantity of gum deposition which may occur if the product is consumed immediately, but does not indicate the stability of the product toward gum formation on storage. As the name implies, the gum is a sticky, tacky, varnish-like material which is objectionable in fuel systems. When present in excess, it tends to clog fuel line filters and pump screens, aircraft engine fuel systems, carburetor jets, and cause manifold deposit and sticky intake valves.

542-1.2.9 NAVAL DISTILLATE FUEL. The primary fuel used in all shipboard power plants (diesel, gas-turbine, and steam-boiler) and is governed by MIL-PRF-16884, **Fuel, Naval Distillate** (NATO Code F-76). F-76 has a minimum flash point of 140° F (60° C). The storage, handling, testing, and use of F-76 for shipboard power plants are covered in **NSTM Chapter 541, Ship Fuel and Fuel Systems**.

542-1.2.10 FLASH POINT. The lowest temperature at which application of a test flame causes the vapors above the surface of a liquid to ignite. Flash points are determined by the use of precision equipment available on most combatant ships. For example, JP-5 is required to have a minimum flash point of 140° F (60° C). The test procedure is described in **NSTM Chapter 541, Ship Fuel and Fuel Systems**.

542-1.2.11 FREE WATER. All water present in fuel, but not dissolved in the fuel, is considered free water. This water can be removed from the fuel by settling, stripping, centrifuging, or filtering.

542-1.2.12 FSII. Fuel System Icing Inhibitor. FSII is a fuel additive that performs two functions. First, it prevents the formation of water-ice in aircraft fuel systems, which can occur in certain susceptible aircraft. Second, FSII acts as a biostat preventing growth of various microorganisms that can contaminate fuel systems, clog filters and promote corrosion.

542-1.2.13 HYDROCARBON. A compound containing only carbon and hydrogen. Hydrocarbons are the principal constituents of petroleum. At room temperature, the lightest hydrocarbons are gases (methane CH₄), but with increasing molecular weight, the compounds are in liquid form (octane C₈H₁₈) and, finally in solid form (eicosane C₂₀H₄₂). There are more than 100 hydrocarbons in gasoline.

542-1.2.14 INERT GAS. For purposes of this NSTM Chapter, a gas mixture that is nonflammable, will not support combustion, and contains a maximum of 3 percent by volume of oxygen; may be used in fire prevention applications.

542-1.2.15 JP-4. JP-4 (NATO Code F-40) is a wide-cut gasoline type jet fuel having a low flash point, typically below 0° F (-17.8° C). Although not routinely used, it has been used by the United States Air Force, Army, and at some shore stations. It is volatile, flammable, and dangerous. JP-4 mixed with JP-5 will lower the JP-5 flash point to an unacceptable level for shipboard use.

542-1.2.16 JP-5. JP-5 (NATO Code F-44) is a kerosene type aircraft turbine fuel having a minimum flash point of 140° F (60° C), specifically designed for storage and use on Navy ships.

542-1.2.17 JP-8. JP-8 (NATO Code F-34) is a kerosene type jet fuel having a minimum flash point of 100° F (37.8° C). It is the NATO standard fuel for use in air and ground vehicles. JP-8 mixed with JP-5 will lower the JP-5 flash point to an unacceptable level for defueling into a fixed shipboard fuel system.

542-1.2.18 MOGAS. Automotive gasoline (MOGAS) is composed of straight run gasoline and cracked stocks in the lower octane rating. MOGAS is stored in a compensated (fixed) system on some amphibious ships for fueling combat equipment. Some missions may require small quantities of MOGAS be made available on ships without a compensated system. These storage requirements shall be satisfied as defined in Chapter 3 and **NSTM Chapter 670, Stowage, Handling, and Disposal of Hazardous General Use Consumables**.

542-1.2.19 OCTANE NUMBER. A numerical measure of the antiknock properties of motor fuel, based on the percentage by volume of isooctane in a standard reference fuel. For example, a motor fuel that produces the same degree of knocking as a standard reference fuel containing 80 percent isooctane has an octane number of 80. Also called octane rating.

542-1.2.20 PARTICULATE MATTER. Solid contamination appearing as dust, powder, grains, flakes, fiber, or stains. It is usually removable by settling, filtration, or centrifugal purification.

542-1.2.21 POL. A broad term which includes all petroleum products used by the Armed Forces. It originated as an acronym for petroleum, oil, and lubricants.

542-1.2.22 REID VAPOR PRESSURE TEST (RVP). The RVP Test measures the volatility of the front end (lighter) components of gasoline at 100° F (37.8° C) and is an indication of its vapor lock tendencies. The vapor pressure of gasoline is a function of its volatility. If the vapor pressure is too low, it is difficult to start the engine. High vapor pressures will result in losses by evaporation and may cause vapor lock in the fuel system of an engine. RVP of MOGAS ranges from 12 to 14 psig in temperate climates and 8 to 9 psig maximum in tropical climates.

542-1.2.23 SURFACTANT. A surface active agent that enhances fuel-water emulsification and can interfere with the removal of free water from fuels. A detergent is one example of a surfactant.

542-1.2.24 TETRAETHYL LEAD (TEL). A colorless, oily liquid added to gasoline at the refinery to improve its antiknock quality. TEL is no longer used, but could remain impregnated in tanks or piping systems. **It is toxic and presents a definite health hazard.**

542-1.2.25 VOLATILITY. The tendency of a liquid to vaporize. RVP is a measure of volatility. A volatile liquid is one that vaporizes at comparatively low temperatures.

542-1.2.26 PQS. Personnel Qualification Standard. The PQS is a compilation of the minimum knowledge and skills that an individual must demonstrate in order to qualify to stand watches or perform other specific routine duties necessary for the safety, security or proper operation of a ship, aircraft or support system.

542-1.3 FUEL DESCRIPTIONS

542-1.3.1 MOGAS DESCRIPTION. MOGAS is a gasoline composed of a mixture of highly volatile liquid hydrocarbons designed for use in internal combustion engines. It is produced from petroleum by a series of complex refining procedures. It is composed of the lower boiling components of petroleum, and is, therefore, **explosive and volatile and must be handled with extreme care.** MOGAS has a low octane rating, and may cause knocking in engines.

MOGAS Data

Specification: ASTM-D-4814 (formerly equivalent to: MIL-G-3056F, cancelled Sep 98)

NATO Code Number: F-46

Octane grade: Motor 83; research 91

Color: Red

542-1.3.2 JP-5 DESCRIPTION. JP-5 is best described as a kerosene type jet fuel. It was developed to provide a higher flash point fuel that could be stored onboard more safely than either gasoline or earlier jet fuels. Like gasoline, it is a mixture of liquid hydrocarbons produced from petroleum. However, JP-5 is composed of higher boiling components than gasoline and is not as explosive and volatile as gasoline. JP-5 is the only grade of jet fuel authorized for fueling aircraft on Navy ships.

JP-5 Data

Specification: MIL-DTL-5624T

NATO Code Number: F-44

Color: varies from clear to amber

542-1.4 FUEL CHARACTERISTICS

542-1.4.1 MOGAS. The following are significant characteristics of MOGAS:

- a. Octane rating of 83 to 91.
- b. Low flash point.
- c. High volatility.
- d. Evaporates readily at ambient temperatures.

542-1.4.1.1 Unwashed Gum. Unwashed gum shall not exceed 10.0 mg per 100 ml of gasoline and should be dry in appearance. If the washed residue is 10.0 mg or less, the gasoline is suitable for all uses. For gasoline exceeding 10.0 mg unwashed gum, use limits are as follows:

- a. More than 10.0 mg but less than 15.0 mg may be used in combat equipment or stationary engines for a period not to exceed 100 hours or 5,000 miles of operation.
- b. More than 15.0 mg but less than 25.0 mg may be used in administrative and transport vehicles for a period not to exceed 100 hours or 5,000 miles of operation.
- c. More than 25.0 mg should not be used in military equipment.

Refer to MIL-HDBK-200G, 1 July 1987 for additional requirements.

542-1.4.1.2 Summer and Winter Gas. Gasoline is classified as summer and winter (class) grades. Class A thru D are summer grades with operating temperatures between 70° F and 109° F. Class E is a winter grade gasoline for use at temperatures below 70° F.

542-1.4.2 JP-5. The following are significant characteristics of JP-5:

- a. Reduced fire and explosion hazard in both ships and aircraft.
- b. High flash point.
- c. No evaporation loss during rapid climbs to high altitude.
- d. Low tendency to cause vapor lock, pump cavitation, and wear.
- e. Versatile: can be used in ship's boilers, diesel engines, and gas turbines as an alternate propulsion fuel.

542-1.5 REFERENCE INFORMATION

542-1.5.1 CHAPTERS IN THE NAVAL SHIPS' TECHNICAL MANUAL. The following chapters in the Naval Ships' Technical Manual (NSTM) are referenced for additional information relative to the MOGAS and JP-5 fuel systems.

- a. NSTM Chapter 074, Volume 1, Welding and Allied Processes
- b. NSTM Chapter 074, Volume 3, Gas Free Engineering
- c. NSTM Chapter 077, Personnel Protection Equipment
- d. NSTM Chapter 079, Volume 2, Practical Damage Control
- e. NSTM Chapter 503, Pumps
- f. NSTM Chapter 504, Pressure, Temperature, and Other Mechanical and Electromechanical Measuring Instruments
- g. NSTM Chapter 505, Piping Systems
- h. NSTM Chapter 510, Heating, Ventilating, and Air Conditioning Systems for Surface Ships
- i. NSTM Chapter 541, Ship Fuel and Fuel Systems
- j. NSTM Chapter 555, Volume 1, Surface Ship Firefighting
- k. NSTM Chapter 555, Volume 2, Submarine Firefighting
- l. NSTM Chapter 583, Boats and Small Craft
- m. NSTM Chapter 593, Pollution Control
- n. NSTM Chapter 631, Volume 2, Preservation of Ships in Service (Surface Preparation and Painting)
- o. NSTM Chapter 670, Stowage, Handling, and Disposal of Hazardous General Use Consumables

542-1.5.2 SHIP INFORMATION BOOK (SIB). Refer to Volume 2 of the SIB for ship-specific information on fuel systems.

542-1.5.3 TECHNICAL MANUALS. Technical manuals furnished for equipment and components of systems installed onboard ship contain detailed descriptions and instructions covering installation, operation, care and maintenance, and safety precautions for the specific equipment.

- a. 0965-LP-060-1010, **GEMS Tank Level Indicating (TLI) System**
- b. S9542-AB-MMO-010, **JP-5 Jet Fuel Centrifugal Purifier**
- c. SG120-AB-MMO-010, **Description and Maintenance of the Electrical Continuity Control System for Aircraft JP-5 Fueling Stations**
- d. NAVAIR 00-80R-14, **NATOPS, U.S. Navy, Aircraft Firefighting and Rescue Manual**
- e. NAVAIR 00-80T-109, **Aircraft Refueling NATOPS Manual**
- f. S9LHD-AC-MAN-010, **Assault Landing Craft Handling/Support Services/Loadout/Facilities Manual**

542-1.5.4 BULLETINS AND INSTRUCTIONS. The following bulletins and instructions related to data in this NSTM Chapter are available for information:

- a. Air Capable Ship Aviation Facilities Bulletin No. I, Department of the Navy, Naval Air Systems Command (NAEC 51122)
- b. Amphibious Assault Ship Aviation Facilities Bulletin No. I, Department of the Navy, Naval Air Systems Command (NAEC 51122)
- c. Aircraft Carrier Aviation Fuel Facilities Bulletin No. I, Department of the Navy, Naval Air Systems Command (NAEC 51122)
- d. COMNAVSURFLANT/COMNAVSURFPAC 4026.1, **Fleet Oiler Manual**
- e. OPNAVINST 5090.1, **Environmental and Natural Resources Protection Manual**
- f. MIL-HDBK-200, **Quality Surveillance Handbook for Fuels, Lubricants, and Related Products**
- g. MIL-HDBK-844(AS), **Military Standardization Handbook for Aircraft Refueling**
- h. MIL-HDBK-291 (SH), **Cargo Tank Cleaning**
- i. OPNAVINST 5100.19, **Series Safety Precautions for Forces Afloat**

542-1.5.5 AVIATION FUEL OPERATIONAL SEQUENCING SYSTEM (AFOSS). AFOSS consists of coordinated, standardized procedures and diagrams for operation of JP-5 aviation fuel systems. These procedures provide detail information for planning, controlling, and directing each fueling and transfer operation. It identifies specific equipment required to accomplish a given evolution, the system alignments, and the sequence of tasks. Aviation ships and some air capable ships have been provided with AFOSS. On air capable ships, it is common for the aviation fuel system operational procedures and diagrams to be found in the Engineering Operational Sequencing System (EOSS). AFOSS takes precedence over all other operating instructions. AFOSS shall be updated as part of the fleet modernization program (FMP) (SHIPALTS). The installing activity is responsible for ensuring changes are incorporated into AFOSS.

542-1.5.6 CARGO FUEL OPERATIONAL SEQUENCING SYSTEM (CFOSS). CFOSS consists of coordinated, standardized procedures and diagrams for operation of the MOGAS systems on amphibious ships and the cargo fuel systems and JP-5 systems on fleet oilers. The system provides information for planning, controlling, and directing each fueling and transfer operation. It identifies specific equipment required to accomplish a given evolution, the system alignments, and the sequence of tasks. When amphibious ship MOGAS systems are provided with CFOSS, CFOSS takes precedence over all other operating instructions. CFOSS shall be updated as part of the fleet modernization program (SHIPALTS). The installing activity is responsible for ensuring changes are incorporated into CFOSS.

SECTION 2

SAFETY

542-2.1 RESPONSIBILITY OF COMMANDING OFFICERS

542-2.1.1 The precautions set forth in this section are minimum safety precautions to be observed when working with gasoline or JP-5 aviation fuel. The Commanding Officer shall issue supplemental orders, as judgment dictates, regarding additional safety procedures. Refer to **NSTM Chapter 670, Stowage, Handling, and Disposal of Hazardous General Use Consumables** for additional instructions for storing containers of gasoline. Refer to **NSTM Chapter 077, Personnel Protection Equipment** for additional guidance concerning personnel protection.

542-2.2 HAZARDS OF HANDLING GASOLINE

542-2.2.1 **EXPLOSIVE MIXTURES OF GASOLINE AND AIR.** Gasoline is a highly volatile liquid that gives off a vapor under normal ambient conditions. This vapor, when combined with air in the proper proportion (approximately 1.4 to 7.6 percent by volume), forms an explosive mixture that can be set off by any ignition source, such as a slight spark or flame. If liquid gasoline is present, a violent explosion followed by fire will result. Air at ordinary atmospheric temperatures can absorb as much as 28 percent gasoline vapor; the most volatile grades will be absorbed in the highest percentages. Gasoline vapors are 3 to 5 times heavier than air, and will tend to sink to the lowest-level compartment when released.

542-2.2.2 **HIGH PRESSURE AND TEMPERATURE.** Gasoline in a closed container generates a pressure of approximately 5 to 15 psi at 100° F (37.8° C) depending on the grade of gasoline. Subject gasoline only to the pressures necessary for operations such as pumping and filtering. The flash point of gasoline is approximately -45° F (-43° C). Keep as cool as possible in storage, transfer, and usage. Heat, if excessive or prolonged, may result in an explosion and fire.

542-2.2.3 **PERSONNEL HAZARDS.** Gasoline and gasoline vapors are toxic. Breathing air rich in gasoline vapors can cause death. Gasoline vapors, even in concentrations of less than one percent, will cause nausea and headache if inhaled for any length of time. Inhalation of air heavy with gasoline vapors has caused unconsciousness and death. Strong concentrations of gasoline vapors produce an excitement stage leading to unconsciousness. Rest and fresh air may correct this condition within a few hours, but all physical reactions resulting from gasoline inhalation or ingestion shall be reported promptly to a medical representative. Gasoline can cause severe flesh burns. Gasoline saturated clothing will burn or irritate the skin. It will ignite if near a source of ignition. Gasoline splashed into the eyes may result in blindness. **Avoid contact with gasoline or breathing gasoline vapors.** Refer to paragraph [542-2.4](#).

542-2.3 HAZARDS OF HANDLING JP-5

542-2.3.1 **FIRE HAZARD FROM HIGH TEMPERATURE OR WICKING.** Even though JP-5 fuel does not give off enough vapor to burn at ordinary temperatures, it can be ignited by heating it above the flash point. The minimum flash point of JP-5 is 140° F (60° C). JP-5 heated to 140° F gives off a vapor which, when combined with air in proper proportion, forms an explosive mixture that can be set off by a slight arc, spark, or flame. A violent explosion will result, followed by fire if liquid JP-5 is present. Keep as cool as possible in storage and transfer. Heat, if excessive or prolonged, may result in a fire. Fire can start in a supply of JP-5 at a temperature

below the flash point if some fuel runs onto an absorbent solid, **such as clothing**, to form a wick. Heat applied to part of the wick will generate enough vapor to feed the flame. **JP-5 soaked clothing remains a fire hazard for days.** A fine spray or film of JP-5 Fuel can also be ignited and will continue to burn since the spray droplets entering the flame zone will be heated until they are vaporized.

542-2.3.2 PERSONNEL HAZARDS. Although JP-5 is much less volatile than gasoline, the toxic vapors cause serious effects if breathed in a confined space for any prolonged period. JP-5 vapor when inhaled may result in headaches, dizziness, nausea, unconsciousness, and death. JP-5 saturated clothing will burn or irritate the skin. It will ignite if near a source of ignition. JP-5 splashed into the eyes may result in blindness. Many people develop skin irritations from contact with JP-5. **Avoid contact with JP-5 or breathing JP-5 vapors.** Refer to paragraph [542-2.4](#).

542-2.4 PRECAUTIONS FOR GASOLINE AND JP-5

542-2.4.1 PERSONNEL PROTECTION. In order to avoid the personnel hazards mentioned above, observe the following precautions (refer to **NSTM Chapter 077, Personnel Protection Equipment** and OPNAVINST 5100.19, **Safety Precautions for Forces Afloat**):

- a. Avoid breathing JP-5 or gasoline vapor. **Breathing these vapors can cause death.** Physical reactions from gasoline or JP-5 vapor inhalation shall be reported to a medical representative. Refer to **NSTM Chapter 074, Volume 3, Gas Free Engineering**, for further information.
- b. When there is reason to believe that atmospheric conditions in a space are not safe, notify the gas-free engineer for further direction to proceed.
- c. Avoid skin contact with JP-5 or gasoline. Wash as soon as possible with soap and water if contact occurs. Wear chemical goggles, face shield, apron, and foot covers when spills may occur.
- d. If JP-5 or gasoline gets into a person's eyes, the following first aid shall be given immediately: Flush the eye with water, then seek immediate medical attention.
- e. Wipe all fuel spills immediately and put wiping rags in firesafe drums for disposal in accordance with ship's instructions. A rag soaked in either JP-5 or gasoline is highly flammable.
- f. Avoid fuel spills on clothing and remove clothing if spills occur. Have gasoline or JP-5 soaked clothing washed or cleaned as soon as possible. Since JP-5 will not evaporate readily, soaked clothing may be a fire hazard for a period of days.

542-2.4.2 ENTRY INTO FUEL TANKS. Entry into fuel tanks for inspection, cleaning, repair, or any other purpose involves certain hazards to personnel. The prescribed safety precautions shall be rigidly adhered to. Fuel tanks shall be entered in accordance with the procedures described in **NSTM Chapter 074, Volume 3, Gas Free Engineering**. No person shall enter a gasoline tank or cofferdam, a JP-5 tank, or any void accessing such tanks, without obtaining permission from the Commanding Officer, who will ensure that all necessary precautions are taken.

542-2.4.3 FILTER SEPARATOR ELEMENT REPLACEMENT. Filter separator elements that have been used or tested in any type of fuel are a fire hazard. Remove and place in firesafe containers for disposal according to HAZMAT instructions in **NSTM Chapter 593, Pollution Control**. Replacement of elements shall be accomplished in accordance with PMS.

542-2.4.4 **SLUDGE DISPOSAL.** Sludge removed from gasoline or JP-5 tanks during cleaning and stripping presents the same kind of hazard as filter elements. Place sludge in firesafe containers for disposal in accordance with HAZMAT instructions in **NSTM Chapter 593, Pollution Control.**

542-2.4.5 **SPRAY-SHIELDED FLANGED CONNECTIONS.** Flanges for piping systems conveying flammable fluids shall be provided with spray shields to prevent spraying of flammable fluids on hot surfaces or electrical equipment. Refer to **NSTM Chapter 505, Piping Systems** for fabrication and installation requirements.

542-2.4.6 **JOINTS AND LEAKS.** Tight joints in all piping systems are essential to safety. Correct all leaks immediately.

542-2.4.7 **USE OF PORTABLE ELECTRIC EQUIPMENT NEAR FUEL.** Avoid use of non-explosion proof portable electric equipment in the vicinity of JP-5 or MOGAS tanks and fueling stations, and gasoline weather deck storage locations. When required, fit with explosion-proof enclosures and heavy wire guards and test for complete insulation before use. Naked lights such as oil lanterns, candles, and cigarette lighters are forbidden.

542-2.4.8 **HOT WORK NEAR GASOLINE AND JP-5.** Do not undertake any repairs involving hot work in the vicinity of JP-5 or MOGAS tanks and piping without first obtaining a gas-free certificate and hot work permit. Hot work in the area of gasoline weather deck storage locations will require off-loading the portable containers, or relocating to a temporary approved area deemed safe by the Commanding Officer. Observe special precautions, as outlined in **NSTM Chapter 074, Volume 1, Welding and Allied Processes**, and **Volume 3, Gas Free Engineering**.

542-2.5 SPECIAL PRECAUTIONS FOR GASOLINE

542-2.5.1 **RECEIVING, STORING, AND DISCHARGING GASOLINE.** Whenever gasoline is handled, pay special attention to the observance of all safety precautions; assign only the most experienced, trustworthy and PQS qualified personnel to the duty.

WARNING

Smoking and machinery operation are forbidden in the vicinity of gasoline tanks or filling connections during fueling operations. Secure all hot work, and place the smoking lamp out throughout the ship.

542-2.5.1.1 **Bulk Gasoline.** Gasoline received in bulk is taken onboard by hose from the delivery source. Before connecting the hose, connect an insulated cable between the supply outlet and the receiving inlet with sufficient slack in the cable to prevent tension. An electrical switch shall be installed in the cable near the receiving point. Do not close the switch until the cable is connected to both points. The cable shall remain in place until delivery of fuel is secured, the hose disconnected and capped, and receiving valve is closed and capped, to ensure that no spark will occur except in the switch, which shall not be opened until the hose fittings are capped and the receiving valve is closed and capped.

542-2.5.1.1.1 When filling or discharging gasoline tanks, proceed as follows:

1. Do not vent through manholes or into interior spaces.
2. Close hatches and ports in the vicinity of outboard vents and overflow lines.
3. Ventilate interior spaces thoroughly after tanks are filled (or discharged) and secured.

542-2.5.1.1.2 Topping-off must be handled with care to prevent fuel overflow. If necessary, reduce the receiving rate. Leave sufficient tank volume available for drainback of all gasoline in the piping and equipment. Normally gasoline tanks are not filled above 80 percent capacity in port. Operational commanders may authorize filling tanks to 95 percent.

542-2.5.1.2 Containerized Gasoline (All Types). Gasoline stored in NAVSEA approved drums, bladders, and rigid metal shall be located in the weather in accordance with **NSTM Chapter 670, Stowage, Handling, and Disposal of Hazardous General Use Consumables**. The only exception to this requirement is ships with specific radar cross-section requirements (RCSR) that prohibit ship external storage. Ships with RCSR shall be designed and sufficiently outfitted to support internal gasoline storage, in NAVSEA approved containers, with fixed fire fighting capabilities.

542-2.5.2 GASOLINE HAZARD AREAS. Gasoline hazard areas are those areas where gasoline or gasoline vapors may be present in quantities sufficient to produce explosive or ignitable mixtures.

542-2.5.2.1 Designation of Gasoline Hazard Areas. Hazard areas include gasoline spaces such as:

- a. Tanks
- b. Tank compartments
- c. Tank cofferdams
- d. Pump rooms and motor rooms
- e. Access trunks
- f. Piping trunks
- g. Jettisonable storage racks and lockers
- h. Enclosed service stations and replenishment stations
- i. Areas within an open horizontal distance of 15 Feet of replenishment stations and service stations, except in service stations that are located in the weather and have open grating
- j. Elevator trunks and pits, and spaces that are open to hangars or vehicle storage and fueling areas
- k. Areas within 4 feet above the deck of hangars and well decks on landing ships and docking ships where gasoline fueled vehicles are stored or fueled, and within 4 feet of highest waterline in docking wells of docking ships
- l. Compartments next to gasoline tank compartments and cofferdams surrounding gasoline storage tanks
- m. Compartments with direct access to gasoline hazard areas unless the doors opening into the spaces are classified X, Y, Z, Circle X, or Circle Y
- n. Compartments with ventilation exhaust ductwork serving gasoline hazard areas
- o. Areas within an open horizontal distance of 15 Feet from the weather access to gasoline cargo tanks, pump-rooms, or other gasoline hazard areas with access from the weather

p. MOGAS Bladder Storage Compartment (LPD-17 Class)

542-2.5.2.2 Warning Plate for Gasoline Hazard Areas. A warning plate is required to be installed in a conspicuous place or places near the access to (and in) possible gasoline hazard areas. Inscribe the following in red letters: **WARNING: Gasoline hazard area. Smoking, use of naked lights, matches, or lighters, use of tools that may produce sparks, wearing of clothing or shoes with exposed metal attachments, and any other actions leading to ignition of gasoline vapors are not permitted.** If such a warning plate is not posted, fabricate and install one in the areas indicated.

542-2.5.2.3 Ventilation Requirements For Gasoline Hazard Areas. All spaces into which gasoline vapors issue must be constantly and thoroughly ventilated, observing the precautions in **NSTM Chapter 510, Heating, Ventilating, and Air Conditioning Systems for Surface Ships** and **Chapter 074, Volume 3, Gas Free Engineering**. As a precaution, operate the ventilation system continuously whenever gasoline is onboard. Take the exhaust from low points of the compartments. During the time work is going on, continuously ventilate, with a portable blower, gasoline storage tanks and compartments not otherwise ventilated. An air or water motor-driven exhaust blower is preferred, although explosion-proof electric motor-driven blowers may also be used. Portable blowers, when used, shall be grounded to the ship's hull and shall discharge overboard free of all air supply intakes.

WARNING

Ship's LP air quality may not be sufficient for prolonged breathing.

542-2.5.2.4 Breathing Protection in Gasoline Pump Rooms. Supplied Air Respirators with Self-Contained Breathing Apparatus (SAR/SCBA) are provided to each ship and assigned to the Gas Free Engineer (GFE). The SAR/SCBA is for securing equipment and evacuating the space, not for normal maintenance. The SAR/SCBA is a portable air source positioned in a non-IDLH atmosphere with airlines to a positive pressure, pressure-demand respirator with a 15-minute back-up air supply (refer to **NSTM 077, Personnel Protection Equipment**).

542-2.5.2.5 Internal Ship Portable Gasoline Movement. In some configurations, MOGAS is stowed for contingency use to support USMC/EOD/Special Forces operations. In some instances, the containerized MOGAS may be taken ashore. Ensure a specific transit path is established and approved by the Commanding Officer and Fire Marshall. A specific firefighting plan/bill shall be established for the entire route of travel. The smoking lamp shall be extinguished prior to and during the movement of MOGAS. All hot work shall be secured prior to and during the movement of MOGAS.

542-2.5.3 WARNING PLATES FOR ELECTRIC MOTOR-DRIVEN GASOLINE PUMPS. The motors for gasoline pumps, and seawater pumps used for gasoline storage tank seawater compensating systems, are located in a separate gasoline pump motor room. They are separated from the pumphouse by an airtight bulkhead. Motor controllers for gasoline and seawater pumps are located near the entrance of the access trunk of the pumphouse. In addition, a disconnect switch is installed in the control circuit of each gasoline and seawater pump.

542-2.5.3.1 The disconnect switches are located at the entrance to the access trunk of the pumphouse and are required to have an instruction plate inscribed: **Gasoline and seawater pump disconnect switch, open at all times when pumps are not in use.**

542-2.5.3.2 An instruction plate is also required at the pumps and inscribed: **Power to electric motor-driven gasoline and seawater pumps shall be shut off at all times except when required. When securing plant, open gasoline and seawater pump disconnect switches at the entrance to access trunk to gasoline pumphouse.**

542-2.6 FUELING

WARNING

For pressure or gravity fueling, connect ground wire from deck metal to the aircraft, then ground the nozzle to the aircraft before removing filler cap.

542-2.6.1 FUELING AIRCRAFT WITH JP-5. Before attaching the pressure nozzle to an aircraft, connect ground wire from deck metal to aircraft. After fueling or defueling, disconnect the nozzle from the tank filler connection before the aircraft ground wire is removed from the deck connection. Make sure the fuel tank filler cap is secured.

WARNING

All personnel shall remain clear of the area between the fuel hose and the port deck edge after the helicopter has received the fuel hose. If the hose should be drawn taut, personnel in this area could be pulled overboard.

542-2.6.2 HELICOPTER INFLIGHT REFUELING WITH JP-5. All personnel involved in Helicopter Inflight Refueling (HIFR) operations shall observe the following safety rules:

- a. Check the grounding circuits on jacks, clip, nozzle, and automatic breakaway unit for circuit continuity.
- b. Check the pressurized hose for leaks; depressurize, but do not drain the hose.
- c. Lower all flight deck safety nets (if applicable) and other obstructions.
- d. Inspect the entire area of the ship that is subject to helicopter rotor wash to prevent Foreign Object Damage (FOD).
- e. The rescue boat shall be made ready and the boat crew shall be on station.
- f. Secure all hatches and scuttles in the refueling area.

WARNING

Personnel shall not touch the hoist hook as it is lowered from the helicopter. Static discharge may be dangerous.

- g. During initial hookup, ground the pickup hook with the grounding wand to avoid electrical shock from the aircraft hoist cable.

WARNING

The flash point of fuel in any aircraft must be confirmed to be 140° F or above before defueling into ship's JP-5 system.

542-2.6.3 SHIPBOARD HANDLING OF AIRCRAFT FUEL JP-4 and JP-8 are jet fuels used by the United States Air Force and Army. Jet A-1 and Jet A aviation turbine grades are used commercially. These other aviation turbine fuels all have flash points that are significantly lower than the minimum 140° F of JP-5, and would dangerously lower the flash point of JP-5 if defueled into the ship's JP-5 system. Navy and Marine Corps aircraft are sometimes fueled at land-based stations or through in-flight refueling evolutions with these low flash point fuels. **A flash point test shall be conducted on fuel extracted from aircraft low-point drains before defueling any aircraft. Aircraft with fuel having a flash point less than 140° F shall not be defueled into the ship's JP-5 system or drained into any other shipboard system, such as an oily waste system .** The portable defuel cart and aircraft to aircraft transfer cart are components designed for the handling of aircraft fuel. **The preferred method of handling all fuel not allowable back into the ship's JP-5 system is transfer to another aircraft in order to recapture usable fuel .** Where permitted by **NSTM Chapter 593, Pollution Control** , defueling overboard can be accomplished by either the portable defuel cart or the aircraft to aircraft transfer cart. In addition to NAVAIR 00-80T-109, Aircraft Refueling NATOPS Manual, paragraph [542-6.12](#) provides detailed information for the aircraft to aircraft transfer cart. [Paragraph 542-6.13](#) provides detailed information for the portable defuel cart.

542-2.6.3.1 AIRCRAFT WASTE FUEL DRAIN. Some ships are configured with aircraft waste fuel drain connections. These connections are typically equipped with a funnel for easy disposal of accumulated low point drains. The aircraft waste fuel drain piping typically leads to a dedicated holding tank for processing. The processing of this fuel is to be accomplished by the ship's oily waste system and **shall not be considered aviation fuel and it shall not be admitted into the ship's JP-5 system** . The funnel, piping, tank and all associated equipment for the tank shall not be considered part of the Aviation Fuel System.

542-2.6.4 FUELING VEHICLES AND PORTABLE CONTAINERS WITH GASOLINE. Before inserting the refueling nozzle into the fueling connection, grounding wires shall be attached to dissipate static electricity. The following grounding sequence shall be followed: attach the grounding wire to the deck or ship's structure, then to the vehicle or container being filled; next, attach a ground wire to the source from which gasoline is being drawn to the vehicle or container being filled. Only after the grounding is complete shall the fill cap be opened or removed. When the refueling evolution is completed and the fill cap is reinstalled, the grounding wires shall be removed in reverse order.

542-2.7 FIRE PROTECTION

542-2.7.1 FIREFIGHTING REFERENCES. Full details on all Naval shipboard firefighting apparatus, together with procedures for their use, are given in **NSTM Chapter 555 Volume 1, Surface Ship Firefighting** and **NSTM Chapter 555 Volume 2, Submarine Firefighting** . Personnel shall be required to carefully study the information given in **NSTM Chapter 555** , and shall be thoroughly indoctrinated in the proper procedures and safety precautions for the firefighting systems of their specific ship. Firefighting procedures involving flammable liquid fires that occur on flight and hangar decks are addressed in NAVAIR 00-80R-14, **NATOPS, U.S. Navy, Aircraft Firefighting and Rescue Manual** .

542-2.7.2 CLASS B FIRES (FLAMMABLE LIQUIDS). Class B fires involve flammable liquids such as gasoline, JP-5 or other jet fuels, and oil. These fires are extinguished with Halon, Hepta flourpropane (HFP), aqueous film forming foam (AFFF), potassium bicarbonate (PKP), or carbon dioxide (CO₂). Information and instructions pertaining to the care, use, location, hazards, and limitations of these firefighting methods are provided in **NSTM Chapter 555**.

542-2.8 APPARATUS FOR TESTING ATMOSPHERE NEAR FUEL

542-2.8.1 PORTABLE INERTNESS ANALYZER. The portable inertness analyzer (see [Figure 542-2-1](#)) is a battery-powered instrument used to indicate the percentage of inert gas in spaces surrounding the gasoline storage tanks, piping, and filters. The portable inertness analyzer is a GOWMAC Model 20-500 (NSN 6630-00-422-2190), and is used for testing inerting systems.

NOTE

Calibrate analyzer for ship specific inert gas (carbon dioxide or nitrogen).

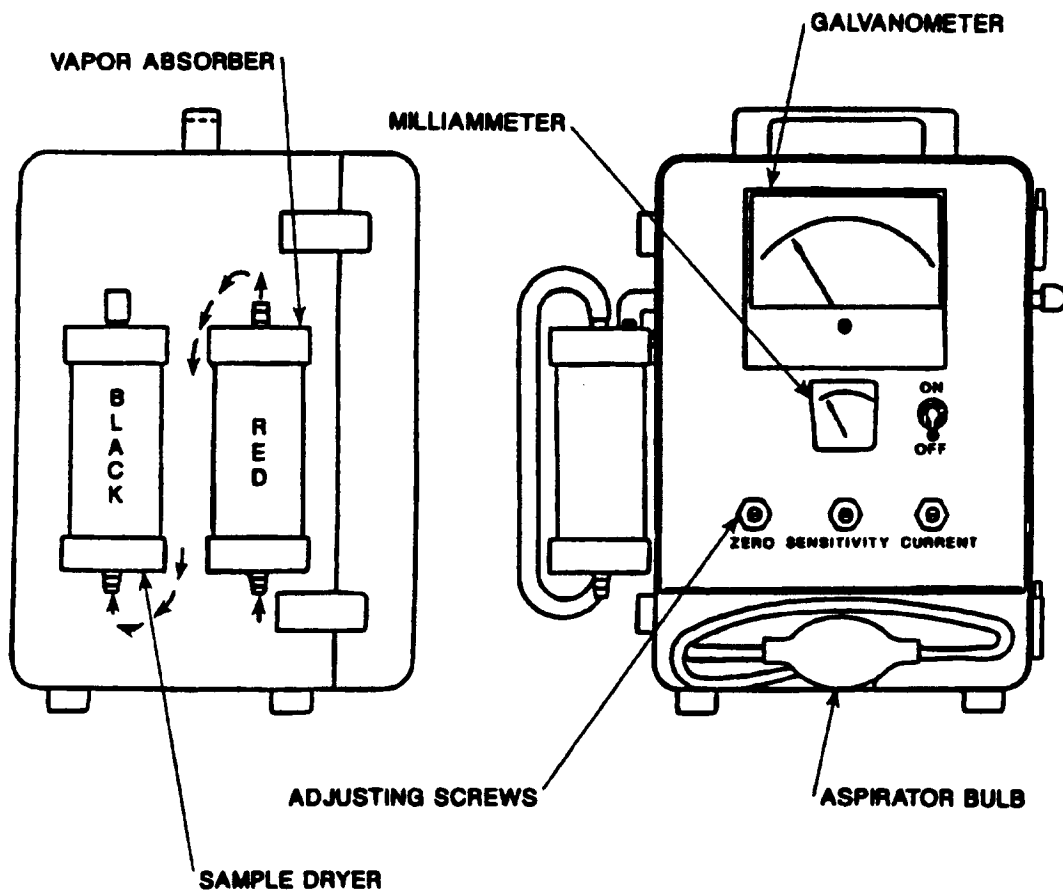

Figure 542-2-1. Portable Inertness Analyzer

542-2.8.1.1 Description. The portable inertness analyzer is contained in a case with a carrying handle. On the front of the analyzer are the controls, indicating dials, and an aspirator pump for drawing samples. The removable front panel provides access to the 6-volt battery compartment. Two chemical cylinders are mounted on the

side of the box. The red one is the vapor absorber, which is filled with activated carbon. This cylinder absorbs only explosive vapors. The black cylinder is the dryer, and it is filled with calcium chloride, a drying agent. The dryer absorbs moisture from the sampled air.

542-2.8.1.2 Principles of Operation. The portable inertness analyzer operates as follows:

- a. The sample is pumped through the vapor absorber and the dryer. The sample then passes through two cells, each containing an incandescent filament. These are two legs of a balance Wheatstone Bridge circuit. The other two legs are comparison filaments sealed in cells to prevent contact with the air stream.
- b. The presence of inert gases in the air being tested changes the electrical resistance of the open filaments, creating a greater voltage on one side of the circuit. Current flows while the circuit is unbalanced.
- c. The flow of current deflects a galvanometer which indicates the percentage of nitrogen gas in the sampled air. When the meter reads zero percent inertness, it indicates the normal 21 percent oxygen content of air. The degree to which oxygen has been replaced in the air by inert gas is thus shown by the readings on the dial.
- d. In a compartment charged with nitrogen gas, an inertness of about 50 percent as shown by the analyzer will give full protection from fire regardless of the amount of fuel vapor which may be present.
- e. The power switch is a toggle switch marked **ON** and **OFF**. In the **OFF** position, the meter is not operating; when the switch is moved to the **ON** position, current is supplied from the battery to the testing circuit.
- f. Battery current is regulated by the **Current Adjust** control coordinated with the ammeter (reading in milliamps).
- g. The galvanometer needle is zeroed-out for each sampling by adjustment of the **Zero Adjust** control.
- h. The **Sensitivity** control is used to calibrate the analyzer during calibration procedures.

542-2.8.1.3 Operating Procedures. The following procedures shall be used for testing the percent inertness of a MOGAS cofferdam, or other inerted space.

1. Adjust for air balance.
 - a. Turn the power switch to **ON**.
 - b. Allow about 2 minutes for the analyzer to reach its operating temperature. Adjust the **Current Adjust** control until the ammeter (reading in milliamps) reads 150 mA.
 - c. Connect the aspirator bulb to the hose connector at the bottom of the dryer (black cylinder). Expose the other end of the aspirator bulb to normal room air.

NOTE

If MOGAS vapors are present in the space, a "false" reading may occur. Always clear the analyzer in a well ventilated space known to be free of vapors.

- d. Aspirate air through the analyzer until the galvanometer needle comes to rest.
- e. Set the needle to zero by adjusting the **Zero Adjust** control with a screwdriver. The analyzer is now ready to analyze a mixture of air and inert gas from the inerted space.
2. Proceed as follows to test the percent inertness of an inerted space containing only air and inert gas. This procedure is used for testing cofferdams and the outer portion of double-wall piping.
 - a. Connect rubber hose between the sampling connection on the inerted space and the inlet of the aspirator bulb.
 - b. Connect the outlet side of the aspirator bulb to the bottom (inlet) of the dryer.
 - c. Operate the aspirator bulb until the galvanometer needle comes to rest. This reading is the percentage of inertness in the tested space.
3. Proceed as follows to test the percent inertness of an inerted space containing a mixture of air, inert gas, and gasoline vapors (but no other gases). This procedure is used for testing gasoline piping.

- a. Connect rubber hose between the sampling connection on the inerted space and the inlet of the aspirator bulb.
 - b. Connect rubber hose between the outlet side of the aspirator bulb and the bottom (inlet) of the vapor absorber (red cylinder).
 - c. Connect hose between the top (outlet) of the vapor absorber and the bottom (inlet) of the dryer.
 - d. Operate the aspirator bulb until the galvanometer needle comes to rest (approximately 6 minutes). This reading is the percentage of inertness in the tested space.
4. After each inertness test by the step 3 method, the vapor absorber shall be purged with air to remove gasoline vapors absorbed by the activated carbon.
- a. Connect rubber hose between the top outlet of the absorber and the outlet of the aspirating bulb. (This procedure should always be done with the air entering the top side of the absorber.)
 - b. Operate the aspirator bulb to purge clean air down through the absorber for 3 minutes
5. Upon completion of each analysis, return the power switch to the **OFF** position. Replace the plastic caps back onto all of the hose connections to preserve the life of the calcium chloride in the dryer and the activated carbon in the absorber.

542-2.8.1.4 Maintenance. The following maintenance procedures should be performed to ensure proper functioning of the portable inertness analyzer.

1. With the power switch in the **OFF** position, the galvanometer needle should rest at zero on the scale. If not, adjust it to zero with the slotted screw on the front of the galvanometer.
2. Replace the calcium chloride in the sample dryer after every 50 analyses. The metal can holding the calcium chloride can be removed by loosening the knurled knob at the top of the dryer. Use 4- to 8-mesh calcium chloride of a grade used in drying tubes. Also replace the glass fiber pad at the top and bottom of the dryer with a similar material.
3. After every 50 analyses, the activated carbon should be removed from the vapor absorber and replaced. Alternatively, the activated carbon could be reactivated by thoroughly flushing it with fresh water and then allowing steam to pass through it for about an hour. Before putting the reactivated carbon back in the absorber it must be dry. Be certain to reinstall the glass in the top and bottom to prevent the carbon from running out the hose connectors. When installing the metal container, be certain the rubber gasket fits properly, and then snug up on the knurled knob.
4. The 6-volt batteries need to be replaced periodically. If the current reading does not reach 150 mA when turning the **Current Adjust** control to its maximum position, the batteries shall be replaced. Remove the front panel to gain access to the batteries. When removing the batteries, take care to extract the plug connector. When replacing batteries, do not force the connector as the pins are dissimilar (the large pin goes to the (+) terminal). Under no condition should a spent battery be left in the analyzer. If the analyzer is to be stored for a long period of time, remove the batteries. Standard batteries that fit the analyzer are Burgess F4PI, Eveready 744, or Bright Star 646.

542-2.8.1.5 Calibration. The portable inertness analyzer is not suited for shipboard calibration. The unit shall be delivered to a calibration laboratory, such as Ships Intermediate Maintenance Activity (SIMA), for calibration in accordance with requirements of the Planned Maintenance System (PMS).

542-2.8.2 COMBUSTIBLE GAS INDICATOR. Combustible gas indicators are designed to detect miscellaneous flammable gases and vapors. They can be used in testing tanks or compartments where flammable gases and vapors associated with gasoline or JP-5 may be present. Refer to **NSTM Chapter 079, Volume 2, Practical Damage Control**, and **NSTM Chapter 074, Volume 3, Gas Free Engineering**, for operation and use, and for manufacturer and model numbers.

542-2.8.3 OXYGEN INDICATOR. The oxygen indicator, a recent replacement for the flame safety lamp (Davey Lamp), is intended solely for the detection of oxygen deficiency in an atmosphere where personnel must

work. Refer to **NSTM Chapter 079, Volume 2, Practical Damage Control**, and **NSTM Chapter 074, Volume 3, Gas Free Engineering**, for operation and use, and for manufacturer and model numbers.

542-2.9 PRECAUTIONS FOR FLEET OILERS

Many precautions are required onboard an oiler. Failure to comply with any one precaution may result in a disaster. Check-off lists help to ensure full compliance. A typical list is shown below, but each Commanding Officer will make whatever additions good judgment dictates when loading and unloading fuel. (refer to [Section 5](#) of this NSTM chapter.)

- a. All personnel handling petroleum shall be made conscious of the danger of fire and explosion, and trained thoroughly in firefighting equipment usage and capabilities.
- b. Firefighting equipment shall be ready for use.
- c. Only safety matches are allowed onboard ship; cigarette lighters are permitted only in authorized smoking areas.
- d. Smoking will be controlled rigidly in accordance with OPNAVINST 3120.32. The smoking lamp is never lighted on the weather decks of oilers.
- e. Use spark producing tools and equipment only at times and places specified by the Commanding Officer.
- f. Conduct burning, welding, or other hot work only in compliance with instructions set forth in **NSTM Chapter 074, Volume 1, Welding and Allied Processes**.
- g. Inspect electrical apparatus weekly, and correct any condition at once that might lead to sparking. Portable electric lights are forbidden in the vicinity of fuel or cargo tanks except in an emergency. If used, they shall be fitted with explosion-proof enclosure and heavy wire guards, and tested for complete insulation before use.
- h. Inspect flame arresters in vents and ullage accesses weekly and maintain in good condition. Ullage screens shall remain in place at **all times** during cargo transfer except for the few seconds required to gage the tanks. During these periods, ensure that rags are **kept out of tanks** by personnel taking soundings.
- i. Inspect shoes to ensure that they are free of spark-causing metal.
- j. Use hammer dogs, butterfly nuts, and similar items with nonsparking tools only.
- k. When tanks are not gas free, use only hoses fitted with a suitable bond to prevent static discharge.
- l. When loading or discharging at night, battle lanterns or nonapproved flashlights **are forbidden** on the main deck in the vicinity of cargo handling operations.
- m. On ships equipped with steam smothering and CO₂ systems, one or both systems shall be in full commission and ready for instant use before cargo handling.
- n. Maintain a tight mooring when fuel hoses are connected, in order to prevent undue strain on the hoses. Do not double up lines by sending out bights. Use additional ends and secure so that each line may be slacked off or taken in readily as the ship changes draft during loading or discharging. Do not moor with steel cable except in emergencies.
- o. All hatches and ports leading into the tank deck shall be closed and dogged during cargo handling.
- p. During cargo transfer, display a red flag (BRAVO) by day; an electric red light by night. **NO OPEN LIGHTS** and **NO SMOKING** signs shall be prominently displayed.
- q. Secure or restrict radio transmitters and radars during cargo fuel handling. Radio frequency radiation hazards might exist because of electrostatic voltages induced in the rigging and other portions of the ship structure. These hazards are primarily caused by voltages induced from antennas fed by transmitters operating at fre-

quencies below 32 megahertz (MHz). The hazards are particularly dangerous within 100 feet of antennas fed by transmitters operating at power outputs of over 250 watts and within 25 Feet of antennas when the power output of the transmitter is under 250 watts. Operation at higher frequencies (above 32 MHz) is not considered dangerous in this respect. The voltage or resonant circuits set up in the ship structure, rigging, or other objects by transmitting equipment can cause shock to personnel and can produce open sparks when contact with personnel or other conducting objects is made or broken.

- r. Do not work general cargo in the area during the transfer of flammable petroleum products.
- s. Forbid unauthorized visitors onboard during cargo transfer, and keep the tank deck clear of personnel not engaged in fuel handling.
- t. Stop transfer operations immediately if any of the following conditions exist:
 - 1 Electrical storm
 - 2 *High wind
 - 3 Cargo spill
 - 4 Tugboat alongside
 - 5 A ship passing close aboard
 - 6 During any emergency
- u. Plug scuppers on the deck during any fuel-handling evolutions.
- v. Put waste, oilskins, paints, or other combustible materials in containers for shore disposal and store away from pumprooms. Dispose of waste and other similar materials saturated with oil or grease as directed by the Commanding Officer.
- w. No person shall enter any tank without having permission from the Commanding Officer and the Gas-Free Engineer. Strictly observe and enforce compliance with the requirements of **NSTM Chapter 074, Volume 3, Gas Free Engineering**, and **NSTM Chapter 541, Ship Fuel and Fuel Systems**.
- x. Before discharging or receiving cargo, open the tank vent valves to the affected tanks.
- y. During the loading of oilers, carefully watch the ullage covers and hatch tops of cargo tanks. Reduce receiving rate in time to prevent an overflow.
- z. Secure hull intake blowers in the vicinity of the loading connections to prevent fuel vapors from being carried into the ship ventilation system.
- aa. Before the start of cargo operations, start all pumproom ventilation blowers to remove any accumulated explosive vapors from the pumprooms.
- ab. During cargo operations, frequently inspect pumprooms to ensure that fuel is not leaking into the bilges.
- ac. Tanks, valves, and pipe lines throughout the ship, including pumprooms and pumps, shall be certified free of gas before ship repairs are made.
- ad. Before starting the flow of fuel, break out and place on deck, available for use, at least four sacks of absorbent material. In case of a fuel spill on deck, take prompt action to stop the flow and absorb the spill.
- ae. Before any loading of bulk liquid cargo and upon completion of discharge of ballast water, drain all suction lines, pumps, discharge lines, and crossovers.
- af. The Liquid Cargo Officer shall ensure that all cargo system valves are in good working condition, that they seat properly, and that their stems are properly lubricated. It is good practice to work master valves by opening and closing them at least twice a month, thereby testing their operating condition.

- ag. Shutting down unexpectedly creates pressure surges that can damage the entire system. **Do not shut down against delivery without providing ample warning. Except in an emergency, always give standbys.**
- ah. After approximately three-quarters of the liquid cargo has been brought onboard, frequently check the draft both forward and aft to stay within the predetermined safe loading limits.
- ai. Information concerning tank capacities, cargo pump capacities, and valve functions is found in the capacity charts, damage control plans, and **Ship Information Book (SIB)** .
- aj. Before receiving fuel, all personnel concerned with the fueling operation shall know the signal system to be used.

542-2.10 HARBOR POLLUTION

542-2.10.1 Oil pollution control requirements and overboard discharge restrictions are provided in OPNAVINST 5090.1, **Environmental and Natural Resources Protection Manual** . The Navy prohibits the discharge of oil and oily waste equal to or greater than 15 parts per million (PPM) worldwide. When beyond 12 nautical miles from the nearest land, for ships equipped with oil/water separators and oil content monitors, and if equipment conditions prevent achieving less than 15 PPM, ships shall limit discharges to less than 100 PPM. For ships without oil/water separators, guidance shall be in accordance with OPNAVINST 5090.1.

542-2.10.2 For additional guidance and more-detailed instruction on overboard discharge requirements for specific situations and locations, applicable regulations shall be referenced. OPNAVINST 5090.1 is the primary reference. Refer also to requirements cited in the **1978 Protocol to the International Convention for the Prevention of Pollution from Ships (MARPOL)**; DOD Directive 6050.15, **Prevention of Oil Pollution from Ships Owned or Operated by the Department of Defense**; and **NSTM Chapter 593, Pollution Control**.

SECTION 3 MOGAS SYSTEMS

542-3.1 INTRODUCTION

542-3.1.1 Compensated (fixed) MOGAS systems are installed on some amphibious type ships to store large quantities of MOGAS in support of USN and USMC Expeditionary Forces. Requirements for receiving, storing, and issuing smaller quantities of MOGAS stored outside a fixed system are specified in **NSTM Chapter 670, Stowage, Handling, and Disposal of Hazardous General Use Consumables**. Paragraph 542-3.2 discusses the three manners of MOGAS storage: (1) seawater compensate storage (paragraph 542-3.2.1.1), (2) inert gas compensated storage (paragraph 542-3.2.1.2) and (3) portable storage (paragraph 542-3.2.2).

542-3.1.2 As described in paragraph 542-2.2.1, a mixture ranging from 1.4 to 7.6 percent of MOGAS in the surrounding air is highly explosive and extremely flammable. Compensated (fixed) stowage systems ensure separation of air and MOGAS, thereby providing for safe storage.

542-3.2 MOGAS STORAGE

542-3.2.1 STORAGE TANK COMPENSATING SYSTEMS. All bulk storage systems operate by the seawater compensating system or by the inert gas compensating system. In the seawater compensating system, seawater displaces gasoline as the latter is drawn off; gasoline displaces water as the tanks are replenished (paragraph 542-3.2.1.1). In the inert gas compensating system, an inert gas blanket fills the vapor space above the gasoline in the tank (paragraph 542-3.2.1.2). Additionally, these storage methods are protected by a cofferdam (paragraph 542-3.2.1.3).

542-3.2.1.1 Seawater Compensated Storage. The seawater compensated system is designed to keep the gasoline storage tanks completely full of liquid at all times, either with gasoline on top of seawater or else completely full of seawater. Seawater replaces the gasoline as it is removed from the tanks. With this method, no explosive vapor pockets can form.

542-3.2.1.1.1 The seawater compensated storage of gasoline is based on two principles.

- a. The weight per unit volume of gasoline is less than that of seawater; therefore, gasoline will float on seawater.
- b. A given height of seawater in a U-tube will hold in balance a greater height of gasoline.

The seawater compensated storage tank is designed on the principle of the U-tube. If gasoline is placed in one leg of the U-tube and an equal volume of seawater in the other, their positions will be similar to that shown in [Figure 542-3-1](#). The storage tanks, containing seawater and gasoline, form the bottom of the tube. The seawater piping forms one side of the tube and the gasoline piping forms the other side.

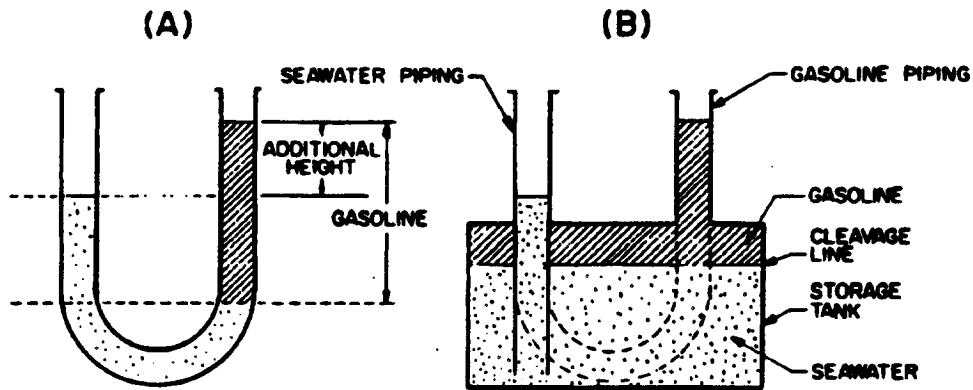

NOTE: GASOLINE IS SHOWN HIGHER IN ITS LEG OF THE U-TUBE SINCE FOR EQUAL VOLUMES, WATER IS HEAVIER THAN GASOLINE.

Figure 542-3-1. U-Tube Analogy (Seawater Compensated [Hydraulic] Gasoline Storage)

NOTE

LHA Class ships were originally constructed with a seawater compensated tank configuration. Authorization via an Alteration Equivalent to Repair (AER) allows the installation and subsequent use of a portable MOGAS holding configuration, thereby providing direction to place the fixed MOGAS system in an inactive status. LHA-1 Class AER No. 07/98, applies.

542-3.2.1.1.2 Seawater compensated tanks are used for bulk storage of MOGAS onboard LHA and LPD ships. Each tank consists of a drawoff tank located inside of an outer storage tank. They are interconnected by a sluice pipe and function as one tank, so that both tank filling and service suction are through the drawoff tank. The gasoline piping connects to the high point of the drawoff tank. The seawater compensated tank may be part of the ship's structure as shown in [Figure 542-3-2](#).

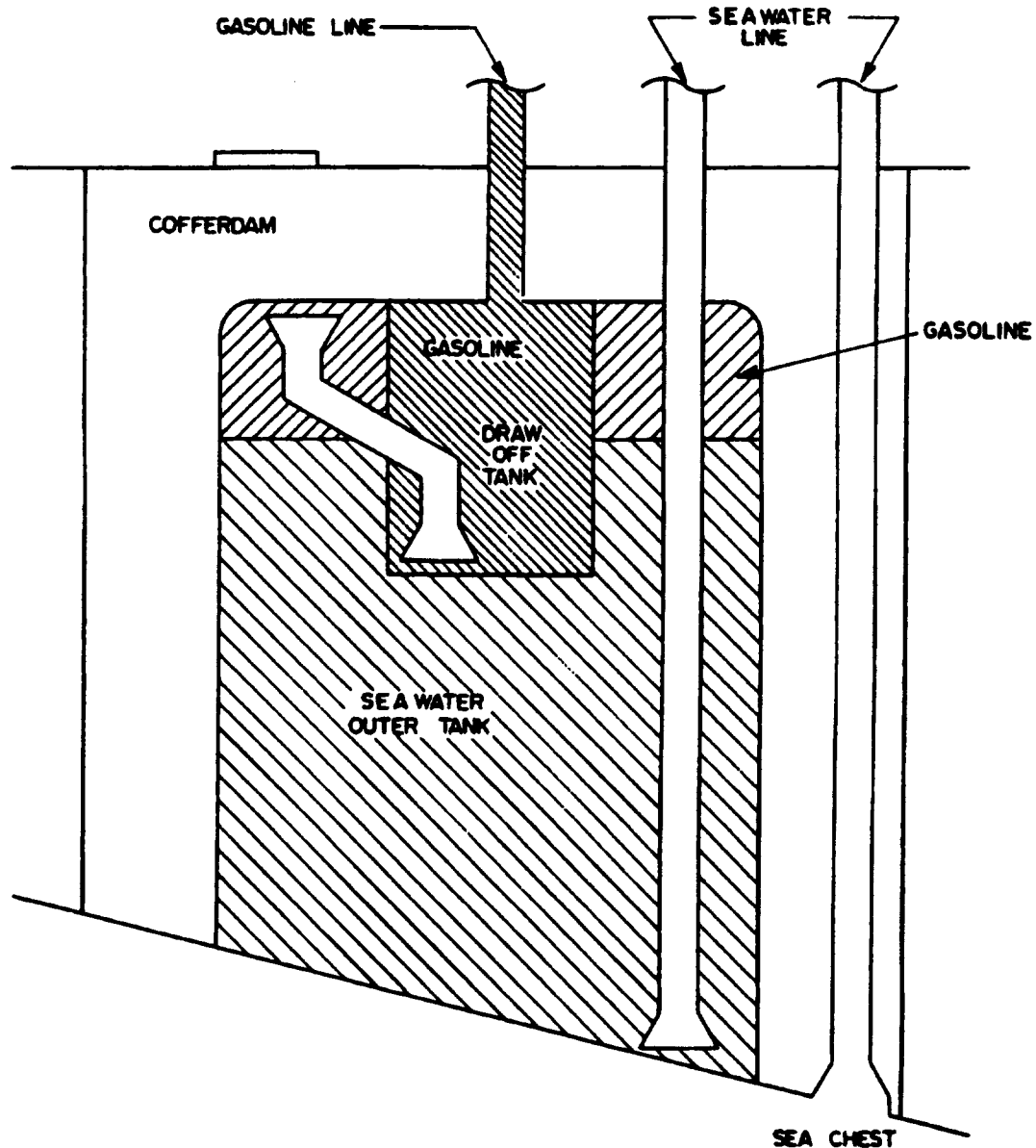

Figure 542-3-2. Seawater Compensated Gasoline Storage Tank

542-3.2.1.2 Inert Gas Compensated Storage. Gasoline vapor is combustible when mixed with air because air contains oxygen, which is an element necessary for combustion. Without the proper proportion of oxygen, fire or explosion is impossible. Carbon dioxide inerting systems protect the gasoline system by preventing air from mixing with gasoline vapors and by reducing the percentage of oxygen. CO₂ is safe for use near electrical equipment because it is a nonconductor.

542-3.2.1.2.1 The inert gas displacement storage tank consists of a single tank and does not require a drawoff tank.

542-3.2.1.2.2 A CO₂ inert gas compensated storage tank is used onboard LST ships. This type of storage uses CO₂ as a protective blanket over the gasoline. CO₂ fills the void area of the tank as gasoline is pumped out; alternatively, CO₂ is forced out of the tank as it is filled with gasoline. Therefore, the tank is always inerted unless it is full of fuel.

542-3.2.1.3 GASOLINE TANK EXTERNAL PROTECTION. In addition to the compensating systems inside gasoline tanks, which protect against explosion by keeping air away from the fuel surface, tanks are also protected externally by a cofferdam around them, as follows:

- a. Rectangular tanks forming part of the ship structure are surrounded by cofferdams except for the points where they intersect with the ship shell.
- b. Tanks independent of the ship shell may be installed in separate tank compartments with controlled atmospheres. Cofferdams and compartments are inerted to protect against fire and explosion. They also serve as voids to collect possible gasoline leaks from tanks. A cofferdam arrangement is shown in [Figure 542-3-2](#).

542-3.2.1.3.1 Nitrogen Inerting of Cofferdams and Piping. Nitrogen (N_2) is an odorless, colorless, and tasteless gas stored at a minimum purity of 97 percent for the protection of MOGAS systems as follows:

- a. The cofferdam, which surrounds the gasoline storage tank, will be inerted to a minimum of 50 percent by volume of nitrogen in order to keep the atmosphere in this space nonflammable and noncombustible. A portable inertness analyzer will be used to determine the inertness of the space.
- b. In the outer portion of the gasoline double-walled piping.
- c. For purging and inerting the gasoline piping and filter after handling operations.

542-3.2.1.3.1.1 Nitrogen is stored in 3000 or 5000 psig flasks or 1800 psig (12400 kPa) cylinders, for use as required. The gas passes from the storage flasks or cylinders to pressure reducing panels. In the 3000 or 5000 psig flask configuration, a regulating valve on each panel reduces the pressure from the stored flask pressure to 300 psig. Three additional pressure regulating valves on each panel further reduce the pressure to the required level. In the 1800 psig (12400 kPa) cylinder configuration, a pressure reducing station reduces the pressure from the stored cylinder pressure to 20 psig (140 kPa). Low pressure distribution piping leads from the regulating valves to the cofferdam, the gasoline double walled piping, and the gasoline distribution piping. Nitrogen for charging the cofferdam is reduced from the low pressure distribution piping. In the 3000 or 5000 psig flask configuration, an additional pressure reducing panel further reduces the nitrogen distribution piping pressure to 3 psig for cofferdam charging. In the 1800 psig (12400 kPa) cylinder configuration, an additional pressure reducing panel further reduces the nitrogen distribution piping pressure to 4 psig (28 kPa) for cofferdam charging. Low pressure piping leads directly from the panel through the gasoline pump room to the cofferdam. A stop valve in the pump room controls the release of nitrogen into the cofferdam. Diffusers at the ends of the distribution lines in the cofferdam distribute the inert gas evenly throughout the space.

542-3.2.1.3.1.2 Vent piping for the cofferdam leads to the outside of the ship. A stop valve in this piping is located in the gasoline pump room. A relief valve is installed in a bypass line around the stop valve to protect against excessive pressure in the cofferdam. An additional relief valve, installed on a cross connection between the nitrogen supply line and the vent piping, may be installed to ensure adequate protection against excessive pressure in the cofferdam. Additionally, relief valves may be installed throughout the nitrogen inerting system in conjunction with the MOGAS system and the double walled piping. Relief valves may be installed at MOGAS fueling service stations, MOGAS ready service stations and nitrogen pressure reducing stations. On the vent piping at each area where a relief valve is located, a pressure gage and inertness analyzer connection is also provided.

542-3.2.1.3.2 CO₂ Inerting of Cofferdams and Piping. The CO₂ inerting system is also used for inerting cofferdams and piping, and operates like the nitrogen inerting system previously described. A minimum inertness of 35 percent by volume is required for CO₂. Cylinders for this system, painted red, are fitted with a handwheel-operated valve but no siphon tube. The CO₂ is fed in a gaseous form through a pressure-reducing valve, via piping to a 300-psig expansion tank.

542-3.2.1.3.2.1 The cylinders and cylinder valves for the CO₂ fire protection system and the CO₂ inerting system are not interchangeable and must never be substituted for each other. Cylinders used in CO₂ inerting systems are not fitted with siphon tubes.

542-3.2.1.3.2.2 Where liquid CO₂ is supplied by vendors, use a vaporizer to convert liquid CO₂ to gaseous CO₂ before introduction into the ship cofferdam inerting piping.

542-3.2.1.3.2.3 Vent piping for the cofferdam leads to the outside of the ship. A stop valve in this piping is located in the gasoline pump room. A relief valve is installed in a bypass line around the stop valve to protect against excessive pressure in the cofferdam. An additional relief valve, installed on a cross connection between the CO₂ supply line and the vent piping, may be installed to ensure adequate protection against excessive pressure in the cofferdam. Additionally, relief valves may be installed throughout the CO₂ inerting system in conjunction with the MOGAS system and the double walled piping. Relief valves may be installed at MOGAS fueling service stations, MOGAS ready service stations and CO₂ pressure reducing stations. On the vent piping at each area where a relief valve is located, a pressure gage and inertness analyzer connection is also provided.

542-3.2.2 Portable Containers Approved portable containers are identified in NSTM Chapter 670. Per Chapter 670, authorized containers for shipboard use are:

- a. Metal/safety cans per Commercial Item Description (CID) A-A-59592 (superseding MIL-C-53109, MIL-S-1285 and MIL-C-1283) or Underwriters Laboratories (UL) 30.
- b. Fifty-five gallon steel drums per Federal Specification PPP-D-729, Type I, Class A.
- c. Fifty-five gallon stainless steel drums per 49CFR172.101 and 46CFR147.45f(3).
- d. Collapsible rubberized fabric drums (bladders) per MIL-D-23119 or specifically approved by NAVSEA.
- e. Rigid portable fuel containers per 46 CFR 147.45f(4).

542-3.2.2.1 Portable containers are stowed aboard ship in a manner in which they may be jettisoned overboard in the event of an emergency. Portable containers may be stowed on a rack, ramp, or grated deck, where, when the release mechanism is actuated, the containers are jettisoned overboard. Additionally, smaller containers, such as 6 or 18 gallon bladders may be stowed in a jettison locker. Similarly, when actuated for release, the containers are jettisoned overboard from the locker.

542-3.2.2.2 Portable containers may also be stowed internally within the ship, in a designated space, specifically designed to house portable MOGAS containers, with NAVSEA approval.

542-3.3 MOGAS SYSTEM COMPONENTS

542-3.3.1 GASOLINE STORAGE TANKS. Storage tanks are rectangular and are provided with either seawater or inert gas compensating systems.

542-3.3.1.1 Tank Coating. Tank coating requirements are contained in **NSTM Chapter 631, Volume 2, Preservation of Ships in Service (Surface Preparation and Painting)**.

542-3.3.1.2 Tank Venting. Seawater compensated tanks are vented at the fill connection for replenishment, and at the station nozzle prior to vehicle fueling. CO₂ compensated tanks are vented through a vent line leading from the tank overboard, above the third deck.

542-3.3.1.3 Tank-Top Pressure Indicators. A gage with a fixed red pointer is connected to the storage/draw-off tank-top for indicating the maximum allowable tank-top pressure. For seawater compensated systems, the red pointer setting is equal to the difference between the design tank-top pressure and the height correction (in psig for the gasoline being used, accounting for specific gravity) from the tank-top to the centerline of the gage. For inerting systems, the maximum tank-top pressure is 4 psig of CO₂ regardless of the amount of gasoline in the

tank. A warning plate with lettering in 1-inch red letters is installed to state one of the following: “**WARNING: This maximum allowable tank-top pressure shall not be exceeded when taking on fuel**” or “**WARNING: Do not exceed maximum allowable tank top pressure when filling MOGAS tank.**” Positive control of the seawater overboard discharge connection is provided. Two configurations exist: (1) a cutout valve, locked open, near the shell and classified W, or (2) a spectacle flange (otherwise known as line blind) normally in the open position.

542-3.3.1.4 Tank Level Indicating System. Two tank level indicating systems exist for outer (bulk storage) or draw-off gasoline tanks, cofferdams or gasoline tank compartments: (1) pneumatic, static head, differential pressure and (2) electrically hydrodynamic. In the electrically hydrodynamic configuration, the indicating system will identify the MOGAS/seawater interface. Additionally, a level switch may be installed in the draw-off gasoline tank and the cofferdam. The draw-off gasoline tank level switch is typically set to activate at the 10 percent level of the tank capacity in order to avoid seawater intrusion from the outer (storage) tank. The cofferdam level switch, located at a nominally low position with respect to the cofferdam bottom, is installed to provide detection of seawater or MOGAS leakage. The switches activate alarms in the gasoline pump room, as a minimum, either visually, aurally or both. Gage panels with appropriate gages for the pneumatic, static head, differential pressure tank level indicating system are installed in the gasoline pump room.

542-3.3.1.5 Tank Sluice Piping and Diffuser. In seawater compensated tanks, a sluice pipe is installed between the outer and the drawoff tank. The upper end of the sluice pipe in the outer tank is located at the highest point of the tank, and the lower end terminates near the bottom of the drawoff tank. The diffuser is mounted on the bottom of the drawoff tank at the end of the sluice pipe. The inert gas displacement system does not require sluice piping.

NOTE

LHA Class ships were originally constructed with a seawater compensated tank configuration. Authorization via an Alteration Equivalent to Repair (AER) allows the installation and subsequent use of a portable MOGAS holding configuration, thereby providing direction to place the fixed MOGAS system in an inactive status. LHA-1 Class AER No. 07/98, applies.

542-3.3.2 PUMPS. Electric motor-driven centrifugal gasoline booster pumps (commonly called gasoline pumps) and seawater compensating pumps are installed on LPDs and LHAs. LSTs have seawater turbine or hand-operated gasoline pumps. The motor-driven gasoline pumps and seawater pumps and associated piping are of nonferrous construction and are installed so that the pumps will not become airborne. The electric motors for the gasoline pumps and seawater pumps that are located in the gasoline pumproom are installed in an adjacent compartment separated from the pumproom by an airtight bulkhead. Motor shaft stuffing boxes in the bulkheads are also airtight.

542-3.3.2.1 Start-stop, explosion-proof pushbuttons for each of the pump motors are installed in the associated MOGAS motor room. A mechanical linkage or explosion-proof intrinsic controller allows remote operation of the gasoline and seawater pumps from the MOGAS pump room. In addition, a disconnect switch is installed in the control circuit of each gasoline and seawater pump. These switches are located in the vicinity of the entrance to the access trunk of the pump room and are fitted with an instruction plate inscribed or similar to: **Gasoline and seawater pump disconnect switch. Contacts shall be open at all times when pumps are not in use.**

542-3.3.2.2 An instruction plate is provided at the pumps and inscribed: Power to electric motor driven gasoline and seawater pumps shall be shut off at all times except when required. When securing plant, open gasoline pump and seawater pump disconnect switches at the entrance to access trunk to gasoline pumproom.

542-3.3.3 VEHICLE FUELING STATION. All vehicles are to be fueled and defueled at the gasoline fueling stations only. Three types of fueling stations are utilized onboard ships.

542-3.3.3.1 CLA-VAL Type Station. Gasoline stations typical of LPDs are of the CLA-VAL fuel-defuel type. The CLA-VAL fueling station consists of one or more solenoid-operated fuel-defuel valves, a positive displacement defueling pump, and the necessary piping, valves, and electric controls to service vehicles through installed hoses. An internal control wire circuit (continuity) is used to activate the CLA-VAL fuel-defuel valve. The fueling station is equipped with 1-1/2-inch gasoline fueling-defueling hoses (MIL-H-17902) which are stored on hose reels. All hoses are provided with adapters, quick-disconnect couplings, threaded nipples, and 1-1/2-inch gravity flow nozzles complete with strainers. Further information on this station is contained in paragraph [542-6.8](#).

542-3.3.3.2 Manual Type Station. Gasoline stations of the manual type are typical to that of the configuration found on LSTs. Flow control is by manual operation of a station cutout valve, fixed defueling is not provided, and hose storage is on a rack or reel. The 3/4 inch fueling hose (MIL-PRF-370) does not utilize the internal control wire circuit (continuity) for valve operation, but is equipped with a static wire in the hose carcass to dissipate any static charge. Only manual operation is provided. All hoses are provided with adapters, quick-disconnect couplings, threaded nipples, and a gravity flow nozzle complete with strainer. The hose supplied is long enough to reach from the rack or reel to the equipment being fueled in its normal refueling area.

542-3.3.3.3 Pressure-Regulating Type Station. Automatic pressure-regulating type gasoline stations include an installed pressure regulating valve to controls the station pressure. Fixed defueling is not provided. Hose storage is on a reel. A 3/4 -inch hose (MIL-PRF-370 or equal) does not utilize the internal control wire circuit (continuity) for valve operation, but is equipped with a static wire in the hose carcass to dissipate any static charge. All hoses are provided with adapters, quick-disconnect couplings, threaded nipples, and a gravity flow nozzle complete with strainer.

542-3.3.3.3.1 MOGAS Ready Service Station/Bladder Stowage The MOGAS Ready Service Station/Bladder Stowage compartment can be found on LPD-17 Class ships, which is designed to issue and store small quantities of MOGAS. Fixed defueling is not provided. The MOGAS Ready Service Station/Bladder Stowage room houses shelving to hold portable containers and is arranged to accommodate the storage of gasoline drum(s). Firefighting provisions and vapor detection is provided.

542-3.3.4 GASOLINE FILTER SEPARATOR. The gasoline riser has a filter separator for the removal of water and sediment from the gasoline. The filter separator has a bypass, a vent and a manual drain. A pilot-operated stop valve at the filter separator outlet prevents delivery of water to the service station. Ship's equipped with filter separators have been authorized to place the filter separators in an inactive status or removed and utilize the bypass. LPD-4 Class SHIPALT 1182D refers.

542-3.3.5 MOGAS Detection Systems On newer ships, a MOGAS detection system may be is installed in spaces where MOGAS vapors could be present. The system is designed to detect vapors in compartments such as MOGAS service stations, MOGAS pump rooms, MOGAS pump motor rooms, and MOGAS Bladder Stowage and Ready Service stations. The system is designed to detect MOGAS vapor at concentrations of 20 percent of its lower explosive limit (LEL). Multiple sensors or detectors must be used where the use of a single sensing

point does not adequately cover adjacent compartments making up the hazard area. A MOGAS detector or detector alarm is located outside the hazard space, adjacent to the access to each gasoline hazard space or group of spaces.

542-3.4 MOGAS SYSTEM PIPING REQUIREMENTS

542-3.4.1 GENERAL. The gasoline piping and equipment within the ship is mainly confined to gasoline spaces such as pump rooms, replenishment or service stations, and similar compartments. Piping within the ship, but external to these spaces, is double-walled and located within trunks. The operation and routine maintenance of the gasoline systems can be performed from outside the inerted cofferdams or gasoline tank compartments.

542-3.4.1.1 Coamings around gasoline pumps and hose reels in enclosed gasoline service stations are provided to collect spilled gasoline. Service mains and branches have a slope toward the storage tank to permit drainback. Pockets are avoided in the gasoline system, or drain piping is provided and led back to the storage tanks.

542-3.4.1.2 Piping is arranged so that seawater compensated storage tanks can be continuously flushed with seawater. Ships having compensating water supplied by a gravity head tank have hose connections in the seawater piping for temporary supply of flushing water. The seawater overflow and filter drain piping are located and arranged to prevent freezing of seawater in the pipes, or heating coils or other means are provided to prevent freezing.

542-3.4.1.3 Gasoline piping has fittings for steaming out by either a pressure or vacuum steaming process. All items of equipment subject to contact with steam are constructed to withstand a temperature of 240° F (116° C) without damage. The number of flanged joints in gasoline piping is kept to a minimum. SAE AMS-C-6183, Type 1 gaskets (Buna-N and cork) should be full-faced, compressed from the original thickness of 0.125 inch to between a minimum gasket thickness compression of 20 percent (0.100 inch) and a maximum compression of 30 percent (0.088 inch). If present gaskets are flat ring, they will be replaced when the joint is repaired.

542-3.4.1.4 A flange is provided on the outboard shell at the seawater overflow line so that, by use of an adapter, a tight joint can be made between the overboard discharge and the vacuum steaming equipment during vacuum steaming out. A portable protector ring is provided to protect the flange face and studs from corrosion. A protective cover is provided for the overflow line and is hinged to permit attachment of the vacuum steaming equipment.

542-3.4.2 TANK FILLING AND DISTRIBUTION PIPING. The system can receive gasoline through a 2-inch, 2-1/2-inch, or 4-inch hose at the gasoline replenishment station. The gasoline filling connection is accessible for connecting to the gasoline hose from a shore connection. To ensure safety, **the filling connection shall be at least 15 feet away from high frequency transmitting antennas or liquid oxygen outlets.** A blank flange or hose cap is provided for the outlet side of the filling elbow. The riser, distribution main, and branches are designed for the specified delivery capacity per hose with a minimum of 10 psig at the outlet of the hose nozzle at the most remote fueling station.

542-3.4.3 PRESSURE-REGULATING AND VENTURI PIPING. On LHAs and some LPDs, the gasoline riser from the gasoline pump is fitted with a combination pilot-operated pressure-regulating valve and venturi located in the gasoline pumphouse. It controls topside pressure at the inlet to the fueling stations. See [Figure 542-6-13](#).

542-3.4.4 PUMP AND VENTURI RECIRCULATING PIPING. A recirculating line, containing an orifice, is installed on the downstream side of the venturi. The rate of venturi recirculation is sufficient to permit satisfactory operation of the regulating valve and venturi combination under a no-delivery condition. A recirculating line, with stop-check valve, is also installed for the recirculation of 5 percent of the output of the motor-driven gasoline pumps and terminates at the mid-height of the drawoff tank. A warning plate is installed at the pump station: **Venturi and pump recirculation line valves must be open before starting pump.**

542-3.4.5 INERT GAS SYSTEM PIPING. The riser from the gasoline pump room, passing through gasoline piping trunks, is double-walled piping. A gage is installed to measure the inert gas pressure in the double-walled piping. The range of the pressure gage is from 0 to 15 psig.

542-3.5 BASIC MOGAS OPERATIONS

542-3.5.1 CFOSS AND SAFETY INFORMATION. All operations of the MOGAS system shall be performed in accordance with the Cargo Fuel Operational Sequencing System (CFOSS). As part of the Personnel Qualification Standards (PQS), insure personnel are thoroughly trained in MOGAS system operating procedures and safety precautions. Observe all gasoline-related precautions throughout [Section 2](#). System operation depends on using the tank, pumps, and gasoline piping exclusively for gasoline. No JP-5 is to be allowed to enter the gasoline system with the exception of using JP-5 as the media for hydrostatic testing in accordance with paragraph [542-3.9.6](#). No gasoline is to be allowed to enter the JP-5 system.

542-3.5.2 PRE-OPERATING FIRE SAFETY CHECK. Before starting any gasoline handling operations, check the following:

- a. Check that nothing will interfere with access to the pull boxes for the CO₂ fixed flooding or Halon fire extinguishing system, or the Hepta fluoropropane (HFP) fire extinguishing system that may serve the gasoline pump room, pump motor room, gasoline filter room (if installed) and the MOGAS Ready Service Station/Bladder Stowage compartment.
- b. Check that nothing interferes with the proper operation of the CO₂ release mechanism at the CO₂ flooding bottle racks.
- c. Check to see that the CO₂ flooding bottles are properly connected to the flooding manifold.
- d. Check to see that sufficient inerting gas (carbon dioxide or nitrogen) is available for purging and inerting the system after fueling operations.
- e. Check to see that emergency air breathing equipment is on-station and properly set up.

542-3.5.3 FILLING SEAWATER COMPENSATED TANKS WITH SEAWATER. Seawater will be taken on only in deep water where the chance of picking up bottom mud or silt is remote. If tanks must be filled before leaving port, use freshwater. To fill the empty tank with seawater, observe the following procedures:

1. Check that the seawater elevated-loop overflow valve in the seawater line is locked open. If icing conditions exist, cut in the steam-heating coils for the seawater overflow line and the seawater overflow vent line. Heaters are located at the hull penetration points.
2. Vent the tank via the filling line to the deck filling connection, bypassing the gasoline pumps, pressure-regulating equipment, and filter separator.

3. For storage tanks below the waterline, line up the seawater piping to admit seawater to the storage tank from the sea chest. This allows seawater to flow into the tank through the overflow line. For storage tanks above the waterline, align the system to admit seawater to the storage tank with the seawater supply pump to the overflow used during gasoline system operation.
4. When the tank level gage for the storage tank reads empty (empty of gasoline but full of seawater), close the valves between the drawoff tank and the gasoline pump suction header. Close the valve from the seawater pump suction header to the overflow line, if used. Close the deck filling connections and the filter and pump bypass valves that were opened.
5. Close all seawater valves opened in [step 3](#) except those locked open.

542-3.5.4 FILLING SEAWATER EXPANSION TANKS WITH SEAWATER. For ships equipped with a seawater expansion tank, fill the empty storage tank with seawater as follows:

1. Fill the expansion tank with seawater from the firemain by placing the pressure-reducing station in operation.
2. If icing conditions exist, cut in the steam-heating coils for the seawater overflow line and the seawater overflow vent line.
3. Vent the storage tank via the filling line to the deck filling connection, bypassing the gasoline pumps and filter separator.
4. Open the expansion tank fill vent and the discharge to the storage tank valves.
5. When the storage tank level gage reads empty (empty of gasoline but full of seawater), close the expansion tank inlet valve. Ensure that the expansion tank is full (indicated on sight glass) and then secure the firemain pressure-reducing station.

542-3.5.5 OPERATING SEAWATER SYSTEM TO PRIME GASOLINE PUMPS. The seawater system serves to force the gasoline through the tank and up to the gasoline pump suction. A pressure of about 1/2 to 1 psig is required at the gasoline pump suction to prevent the gasoline pumps from becoming vapor locked. Start motor-driven seawater pumps, if any, before starting the gasoline pumps. Operate and align at least one seawater pump to discharge to the gasoline tank for each gasoline pump put into operation. Seawater displaces gasoline from the storage tank, thus maintaining a positive pressure on gasoline pump suction. Excess seawater will automatically discharge overboard through the elevated-loop overflow line. (Seawater systems with an expansion tank are placed in service by ensuring that the tank is full, and the discharge valve to the gasoline tank is open.) The procedure is as follows:

1. Line up the system to take suction from the sea and to discharge to the outer tank.
2. Open the suction valve and recirculating valve, if installed, for one seawater pump, then start the pump with the discharge valve closed. When the pump discharge pressure builds up, open the discharge valve slowly.
3. Cut in an additional seawater pump if another gasoline pump is to be placed in operation, using the procedure outlined in step 1 to maintain a positive pressure at the gasoline pump suction.

Seawater turbine-driven gasoline pumps are placed in service by opening the gasoline pump inlet and outlet valves, thus allowing gasoline to flow into the pump casing. Since the seawater turbine and gasoline pump ends are directly connected, the gasoline piping shall be aligned for system operation before opening turbine seawater inlet and outlet valves.

542-3.5.6 RECEIVING GASOLINE. Receiving procedures differ for seawater compensated systems and CO₂ compensated systems.

542-3.5.6.1 Receiving into Seawater Compensated Systems in an Empty Condition Observe the precautions outlined in paragraph 542-2.5.1 and its subparagraphs when receiving gasoline. Proceed as follows:

1. Check that the seawater elevated-loop overflow valve is locked open. Introduce seawater into the tank by gravity from the sea, until the reflex gage at the base of the gasoline pump suction header indicates the presence of liquid. Then close the valve in the gasoline suction line between the drawoff tank and the reflex gage. Close all sea suction valves except the locked-open leakoff valve.
2. Before filling, line up the valves in the piping system to bypass the filter, if installed, the pressure-regulating equipment, and the gasoline pumps. Check that all necessary valves are open.
3. Prepare to take gasoline received in bulk onboard by hose from the delivery source. Before connecting the hose, connect an insulated copper cable (including a single-pole electrical switch) between the source of supply and the receiving inlet, as outlined in paragraph 542-2.5.1.1. **Do not close switch until cable is connected to both the receiving and supply points. The cable shall remain in place until the delivery of fuel is secured at the source, the hose disconnected, and the fittings capped to ensure that no spark will occur except in the switch, which shall not be opened until the fittings are capped.** (When a tank truck is the supply source, use the grounding equipment furnished by the supplier only after verifying that it meets the requirements of paragraph 542-2.5.1.1.) Remove the blank flange or hose cap, and connect the hose to the filling connection. Vent the system through a hose attached to the vent at a remote fueling station. Insert the vent hose nozzle into a safety can, then open the vent valve to permit the displaced inert gas to escape as gasoline is pumped into the system. Open the filling connection valve.

WARNING

Allowable tank-top pressure, as indicated by tank-top pressure indicator, shall not be exceeded when taking on fuel, or tank might rupture.

4. Request the supply source to start pumping very slowly. When fuel appears at the vent hose, close the vent valve. Then check the reflex gage at the gasoline pump suction header to see that it is full. Open the valves between the reflex gage and the drawoff tank and request the supply source to increase filling to a normal rate.
5. When the level gage indicates that the outer tank or storage tank is almost full, stop the fill operation. Allow sufficient space in the gasoline tank for drain back of all gasoline from the piping and equipment.
6. Uncouple the fueling hose, replace the blank flange or hose cap, then open the switch and disconnect the cable.
7. Drain the gasoline piping to the draw off or storage tank by admitting inert gas (nitrogen or carbon dioxide) to the distribution piping, as far from the tank as possible, to displace the gasoline in the piping.
8. Monitor the gasoline pump reflex gage; when the reflex gage indicates the gasoline level has fallen below the header, close the drawoff tank cutoff valve.
9. Open the sea chest valve, if installed.
10. To purge the filling piping, line up all valves in the piping to bypass the gasoline pumps, the pressure-regulating equipment, and the filter separator, if installed. Open the filling liner valve in the pump room. Admit

inert gas to the filling piping through the inert gas supply line in the gasoline pump room. Allow the inert gas pressure to build up and then close supply line valve. Take inertness readings at the deck filling test connection to see if an inertness of 50 percent or better has been achieved when inerting with nitrogen, or 35 percent when inerting with carbon dioxide. If not, bleed down system, recharge, and again check inertness reading.

542-3.5.6.2 Initial Receiving in CO₂ Compensated Systems In an Empty Condition. The following procedure shall be observed:

1. Introduce CO₂ into the tank until inert pressure gage is at 1/2 psig and tank is at 35 percent inertness.
2. Before filling, line up the compensating piping to vent to atmosphere, and the gasoline piping to bypass filter, if installed, pressure-regulating equipment, and gasoline pumps. Check that all necessary valves are open
3. Follow procedure outlined for seawater compensated systems, paragraph [542-3.5.6.1](#), steps 3, 4, 5, 6, and 7.
4. Close CO₂ vent-to-atmosphere valve. Admit CO₂ to gasoline tank until gage reads 1/2 psig and inertness is at least 35 percent.
5. To purge the filling piping, follow procedure outlined for seawater compensated system, step 10 in paragraph [542-3.5.6.1](#).

542-3.5.6.3 Subsequent Receiving in Seawater Compensated Systems. In seawater compensated systems, the storage tank will already be full of seawater or a combination of gasoline and seawater. The distribution system will be charged with inert gas in a secured condition. Under such conditions, the following procedure shall be observed:

1. Check that the sea suction valve is closed and that the seawater elevated-loop overflow valve is locked open.
2. Release the inert gas pressure through the filling connection. Then proceed as outlined in steps 2 through 10 of paragraph [542-3.5.6.1](#) for initial filling.

542-3.5.6.4 Subsequent Receiving in CO₂ Compensated Systems. Before filling the tank with gasoline in CO₂ compensated systems, the distribution system will be charged with inert gas in a secured condition. Under such conditions, release the inert gas pressure through the filling connection vent. Then proceed as outlined in steps 2 through 5 of paragraph [542-3.5.6.2](#).

542-3.5.7 PREPARATION FOR FUELING VEHICLES. The actual fueling of the vehicle is handled by the fueling crew under the direction of the officer responsible for these operations. No one but a PQS qualified operator shall have anything to do with fueling. While the vehicle is being fueled, station one of the gasoline crew with a portable fire extinguisher nearby.

1. Before fueling begins, stop the engine of the vehicle to be fueled and turn all engine switches to the OFF position.
2. Before fueling starts, station a member of the gasoline crew with a swab near the vehicle fueling connection so that any spilled gasoline can be immediately swabbed up or spread around to evaporate quickly. Make readily available a nonsparking pail full of water for rinsing the swab. After rinsing, thoroughly air the swab

in an exposed location. Do not bring a contaminated swab into an enclosed space. Hold rinse water in 5-gallon safety cans and store in a protected space until water can be disposed of per **NSTM 593, Pollution Control**.

3. Before inserting the hose nozzle into a vehicle tank fueling connection, ground the vehicle by attaching a ground wire to bare deck metal and then to the vehicle. Connect the hose ground wire to the vehicle to avoid static sparks which may cause gasoline vapors to explode.

NOTE

Refer to **NSTM Chapter 670, Stowage, Handling, and Disposal of Hazardous General Use Consumables**, for additional fueling requirements. Leaks in tanks, lines, or connections, or trouble with handling equipment, shall be reported immediately to the officer in charge.

542-3.5.8 PROCEDURE FOR FUELING VEHICLES. The following procedure shall be used when fueling vehicles or filling approved containers from a fixed MOGAS system.

1. Check that installed fire fighting systems (such as CO₂, HFP or fixed flooding systems) installed in the pump room(s) and in the fueling stations are in working order and that the remote emergency activation devices are accessible. Ensure AFFF vehicle fire fighting capability is available in the vehicle stowage area.
2. In a secured condition, the piping system will be charged with inert gas. Vent the inert gas into a safety can by opening the vent connection in the distribution system at the fueling station. When the pressure in the system drops to zero psig on the inert gas pressure gage, close the vent.
3. Pressurize the gasoline tank by placing one seawater pump into operation.

NOTE

Ships employing CO₂ compensating systems shall start CO₂ compensating system operation.

4. Line up the distribution system to deliver gasoline from the draw off tank, by way of the gasoline pump, to the fueling station(s) through the pressure regulating equipment and filter/separator, where installed.
5. On ships with a venturi, open the recirculating line downstream of the venturi and open the pump recirculating line for each gasoline pump to be placed in operation. These lines return to the same drawoff tank from which gasoline is taken. On ships provided with seawater pumps, have one seawater pump already running for each gasoline pump to be started.
6. Where installed and operational, vent the filter separator until fluid appears at the vent sight glass. Then open the vents at the deck fueling stations fitted with vent connections until fluid appears at the vent connection.
7. First connect the ground wire to the ship metal structure and then to the vehicle. Then connect the fueling nozzle ground wire to the vehicle. When grounding the vehicle to the ship structure, remove oil, paint, non-skid found on deck tie-downs, or any other substance which might prevent a bright metal contact.

WARNING

On ships equipped with CLA-VAL fuel/defuel valve stations, overriding the electrical continuity system by manually operating the solenoid pilot valve is prohibited.

8. Insert the fueling nozzle into the vehicle tank and start the defueling pump where installed. Operate the defueling pump during both fueling and hose evacuation for the fuel-defuel valve to function properly. Ships employing manual or pressure-regulating fueling stations do not have a defuel pump. Fueling is accomplished by utilizing the gasoline pump and a manual stop valve.
9. At the end of fueling for ships equipped with CLA-VAL fuel/defuel valve stations, close the nozzle, place the quick disconnect coupling (QDC) switch at the nozzle in the defueling position to evacuate fuel from the hose, and remove the hose nozzle from the vehicle. Ships employing a manual stop valve must drain hoses into a safety can. After this has been completed, detach the nozzle ground wire before the vehicle ground wires are removed from the deck connection. Make sure that the gasoline tank cap is secured. Return gasoline drained into safety can to gasoline tank, or dispose of in accordance with **NSTM Chapter 593, Pollution Control**.
10. After all fueling is completed, drain the system and then charge it with inert gas.

542-3.5.9 DELIVERING GASOLINE OFF-SHIP. To deliver gasoline to a bladder, other storage devices, or off-ship, observe the following procedure:

1. Normally, the system will be in a secured condition and will be charged with inert gas. Bypass the pressure-regulating equipment and filter. Then open the main deck filling connection vent and bleed off inert gas until the pressure in the system reaches zero psig.
2. Close the filling connection valve. Then connect the copper cable with switch (as described in paragraph [542-2.5.1.1](#)) between the filling connections and the receiving container inlet. Do not close switch until cable is connected to both the receiving and filling points. The cable shall remain in place until the delivery of fuel is secured at the source, the hose disconnected, and the fittings capped, to ensure that no spark will occur except in the switch, which shall not be opened until the fittings are capped. Attach the transfer hose. Start the seawater or inert gas compensating system and one gasoline pump, then proceed with the delivery operation.
3. After delivery has been completed, close the filling connection valve. Uncouple the hose, then open the switch and remove the cable. Drain the system, then purge and charge it with inert gas.
4. If the storage tank is to be emptied of gasoline, proceed as in one of the following:
 - a For seawater compensated systems, delivery shall be continued until seawater is detected at the gasoline pump suction header. When all gasoline in the tanks has been pumped out, as determined from tank level gage readings, check at the deck test connection for seawater. When seawater appears at the test connection, discontinue delivery. Then drain piping using CO₂ or N₂ inert gas system.
 - b For inert gas compensated systems, continue delivery until the tank level gage reads empty. When all gasoline in the tank has been pumped out, as determined from tank level gage readings, check at the deck test connection for gasoline. When gasoline disappears at the test connection, discontinue delivery. Do not flush the inert gas compensated system.

542-3.5.10 DRAINING AND SECURING SYSTEM. At the completion of any gasoline-handling operation, drain the piping of gasoline, purge of gasoline vapor, and charge with inert gas to minimize fire and explosion hazards. To drain and secure the gasoline system, observe the following procedures:

1. Close all fueling station cutout valves. Check that all fueling station vent valves and the tank filling connection cutout valve are closed. Close all seawater valves except those locked open.
2. Open all gasoline distribution piping valves, including the bypass valves, except those valves closed in step 1. Admit inert gas through the connection at the filter separator bypass (if installed) or other suitable location. The inert gas will bubble up through the gasoline to the high points in the system, displacing the gasoline, and forcing it to drain back to the draw off tank. If a filter separator is installed, open the drain line bypass valve from the filter separator sump to drain off water from the filter separator. When gasoline appears in the drain sight glass, close the drain line bypass valve and, if installed, open the filter separator drain line valve to the gasoline pump discharge line.
3. When the sight glass (also known as reflex gage) in the pump room indicates that all gasoline has drained from the system, close the valve between the draw off tank and the suction header, and close all independent recirculating line valves that discharge to the draw off tank. In water compensated systems, take care to prevent inert gas from entering the draw off tank, as it may form a gas lock in the tank that may prevent pumping and that later must be bled off through the distribution piping.
4. Close affected inert gas inlet valves to the distribution piping, and admit inert gas to the system through the connection just above the sight glass (or reflex gage) in the pump room. Connect a portable inertness analyzer to the fueling stations provided with vent connections. Take inertness reading to determine that at least the required inertness reading (50 percent for nitrogen and 35 percent for CO₂) has been obtained. Also check the inertness reading at other fueling stations. If the correct inertness reading has not been obtained, bleed off some inert gas, build system up to 10 psig, and recheck inertness reading.
5. For draining and securing (after operations in which the filter separator, if installed, is bypassed), leave the filter separator cut out (if installed), and admit inert gas for draining the system through the connection to the filter separator bypass or where applicable. The rest of the procedure, except for draining the filter separator (if installed), will be the same in principle as already outlined.

542-3.6 OTHER MOGAS OPERATIONS

CAUTION

Ships shall be a minimum of 50 nautical miles from shore before flushing. Permission shall be granted from commanding officer before starting to flush.

542-3.6.1 FLUSHING THE WATER COMPENSATED STORAGE TANK. Do not flush or drain the storage tank until all the gasoline from the tank has been off loaded or consumed during normal operations. Flushing procedures vary for each ship class, and shall be performed in accordance with CFOSS or SIB, as applicable. Inert gas displacement gasoline storage tanks are not flushed.

542-3.6.2 EMPTYING OF STORAGE TANKS. Normally, emptying the storage tanks is a shipyard operation, and is done so that repair work can be accomplished. Empty the tanks only after the gasoline has been offloaded and the tank has been completely flushed with seawater. refer to paragraph 542-3.9.8 for flushing requirements.

542-3.6.2.1 To empty the storage tank on ships equipped with motor-driven seawater pumps, observe the following procedure

1. Release the inert gas and vent the system through the deck filling connection, with the pressure regulating equipment and the filter separator, if installed, bypassed.

CAUTION

In port, gasoline tanks shall be offloaded to tank trucks.

2. Close the seawater suction sea valve. Start one seawater pump to take suction from the seawater filling lines for the outer tank and discharge in compliance with OPNAVINST 5090.1.
3. When the seawater pump begins to cavitate, secure the pump, close the gasoline pump bypass valve, and apply air pressure to the drawoff tank through the steaming out connection; continue pumping seawater until the tank is empty.
4. If the gasoline piping has not been steamed out, purge and charge the system with inert gas after the emptying operation.

542-3.6.2.2 To empty the storage tank for ships equipped with expansion tanks, observe the following procedure:

1. Close expansion tank inlet valve from the firemain reducing station.
2. Release the inert gas, then vent the system through the deck filling connection, bypassing the filter separator, if installed.

CAUTION

In port, gasoline tanks shall be offloaded to tank trucks.

3. Empty the expansion tank, ensure expansion tank outlet valve to the gasoline tank is open, and operate the gasoline pumps to discharge seawater through the deck filling connection, in compliance with OPNAVINST 5090.1.
4. Remove the expansion tank outlet valve from the system, and connect the portable eductor suction hose to the gasoline tank piping at the removal point. Eductor inlet and discharge connections are provided in the pump-room.

CAUTION

In port, gasoline tanks shall be offloaded to tank trucks or barges.

5. Install portable eductor inlet and discharge hoses, and activate eductor. Eductor operations shall be in accordance with **NSTM Chapter 079, Volume 2, Practical Damage Control**. Empty the gasoline tank.
6. When the tank is empty, disconnect eductor, and replace expansion tank outlet valve.
7. If steaming-out operation is not to begin immediately, the tank shall be inerted.

CAUTION

During steaming out, all pumps must be replaced by a spool piece (or blank) of non-ferrous metal. Additionally, for ships equipped with filter separators, the filter discharge automatic shutoff valve, the filter automatic drain valve, the filter rotary (float) control valve must be replaced by a spool piece (or blank) of non-ferrous metal.

542-3.6.3 STEAMING OUT. To render gasoline system safe for hot work, remove all vapors and fumes by steaming out after emptying the tank. Steaming out is normally a shipyard operation. It should be accomplished by a vacuum steaming method using a Wheeler type vacuum machine. Steam temperature should be a minimum of 240° F (116° C). Steaming out shall be continuous until system is certified gas-free. It may take 24 hours to complete the evolution. At the completion of steaming out, check all gaskets for tightness. Remove one valve from the line, and inspect for wear. Each time the system or part of the system is steamed out, inspect a different valve.

542-3.6.4 STRIPPING THE DRAWOFF TANK. One of two types of stripping systems can be found in MOGAS systems, a hand-operated or motor stripping system. The intent of the stripping system is to remove sludge and water from the tank bottom for each draw off tank. A stop valve is fitted at the pump suction. A sight glass and a test connection are contained in the discharge line. The discharge piping can lead to the associated outer tank, overboard or to a deck connection. For prohibitions concerning overboard discharge, refer to paragraph 542-2.10. Before fueling, completely strip the draw off tank of water and sludge as follows:

1. Align the system per CFOSS or local procedures.
2. Open pump suction and discharge valves.
3. Operate pump until there is no indication of water passing through the sight glass (clear sample is observed).
4. Secure suction and discharge valves of the pump, and start fueling operations

542-3.6.5 STRIPPING CO₂ COMPENSATED TANKS. A hand-operated stripping system has been provided to remove water from the tank bottom. A stop valve is fitted at the pump suction. A sight glass and a test connection are contained in the discharge piping. The discharge is piped overboard. For prohibitions concerning overboard discharge, refer to paragraph 542-2.10. Before fueling operations, completely strip the storage tank of water and sludge as follows:

1. Open hand-operated pump suction and discharge valves.
2. Operate hand pump until there is no indication of water passing through the sight glass (clear sample is observed).
3. Secure suction and discharge valves of the hand pump, and start fueling operations.

542-3.6.6 USING TANK LEVEL INDICATING SYSTEM. Two types of level indicating systems exist: (1) a pneumatic, static head, differential pressure, liquid level system, or (2) electrical type liquid level system. The pneumatic, static head, differential pressure, liquid level indicator system is installed in outer gasoline tanks and in cofferdams surrounding gasoline tanks or in gasoline compartments. The gages for these systems are arranged on a gage board installed in the gasoline pump room. For cofferdams, gages indicate the presence of liquid, alert-

ing the operator to system failure. The electrical liquid level system is installed in outer gasoline tanks and draw off tanks (GEMS type). In the tank, a float travels along a transmitter rod to reflect the level of the tank and transmits an electrical signal to a receiver for display of the tank capacity. Local receivers are provided in the pump room. On newer ships, the indicating system may be is designed to reflect the MOGAS/seawater interface in the outer gasoline tank. Additionally, a low MOGAS level alarm is typically installed, set to actuate at 10 percent of the draw-off tank. On newer ships, visual and audible alarms may be are installed in the MOGAS pump room. Also, a level switch may be is provided in the cofferdam at the lowest are to detect seawater or MOGAS leakage. For gasoline tanks, gages indicate the following conditions:

542-3.6.7 DRAINAGE OF COFFERDAM AND PUMPROOM. Fixed eductors are used to drain accumulated water or fuel from the cofferdams surrounding storage tanks. Discharge of oily waste overboard is prohibited within any restricted zone in accordance with OPNAVINST 5090.1. (Fixed eductors for direct overboard discharge will be used only for emergency overboard discharge of fuel.) The operating gear for the eductor is located in a watertight box in the gasoline pumproom. Operate the eductor as follows:

1. Connect supply hose between the eductor supply hose valve and the hose valve on the seawater supply line in the pump room.
2. Connect discharge hose between the eductor discharge valve and the hose valve on the overboard discharge line in the pump room.
3. Open the eductor discharge valves.
4. Open the firemain supply hose valve. Ensure prescribed pressure at the eductor supply valve.
5. Open the forward eductor suction valve.
6. Open the eductor supply valve on the water supply line in the pump room.
7. When one end of the cofferdam has been drained, close the forward eductor suction valve and open the aft eductor suction valve.
8. When drainage has been completed, close the water supply and overboard discharge valves and the eductor suction and discharge valves.
9. Disconnect and stow the eductor supply and discharge hoses.

Provision is made for draining the gasoline drain well by a portable eductor, if installed. In this configuration, the drain line terminates with a globe hose valve, enclosed in a watertight box, and located in the pump room. A connection on the fire main fitted with a locked-closed, globe, hose supplies the actuating water to the drain eductor. A locked-closed, globe, stop-check, hose valve is fitted to the overboard discharge line to receive the eductor discharge. Eductor suction is taken from the globe hose valve fitted on the drain line. On newer ships, a dedicated portable eductor may be installed in the vicinity of the MOGAS pump room entry point. The dedicated portable eductor is intended to provide provisions to evacuate liquid from the MOGAS pump room in the event of an emergency. Hoses and adapters should be are provided to make proper eductor connections.

542-3.7 TROUBLESHOOTING

This section lists some of the more common problems that may require troubleshooting. Other problems can be resolved by referring to other sections of this chapter, other chapters in the Naval Ships' Technical Manual (NSTM), the Ship Information Books, and related manuals.

542-3.7.1 WATER IN THE MOGAS SYSTEM. Sources of water contamination are usually limited to residual water from improper tank cleaning procedures and water received along with the gasoline.

- a. Check the operation of the drawoff tank stripping system to see that it is functioning properly.

WARNING

Filter separator, if installed, must be steamed out and certified gas-free before opening manhole.

- b. If filter separator is installed, replace filter separator coalescer elements. Inspect separator elements, and replace as necessary. Ensure that all elements are installed correctly.
- c. If filter separator is installed and equipped with automatic water drain, check to see that the float control valve and the water drain valve of the filter are operating properly.

542-3.7.2 MALFUNCTION OF GASOLINE TANK LEVEL INDICATORS. Refer to the liquid level indicating equipment technical manual and **NSTM Chapter 504, Pressure, Temperature, and Other Mechanical and Electromechanical Measuring Instruments.**

542-3.7.3 PUMP CAVITATION. For any given pump, capacity and efficiency are not affected until the suction lift exceeds a certain value. When this value is exceeded, the pump capacity and efficiency drop. The pump will cavitate and in severe cases may lose prime and seize.

542-3.7.4 FUELING STATION PRESSURE PROBLEM. To limit the pressure at the inlet of the most remote deck fueling station, most ships are equipped with pressure-regulating equipment in the gasoline pump room. If installed and operational, the gasoline filter separator outlet pressure will drop due to the coalescer elements clogging. It may be necessary to readjust the setting of the pilot valve of the automatic pressure-regulating system to maintain the desired pressure at the outlet.

542-3.8 MOGAS SYSTEM MAINTENANCE

542-3.8.1 TOOLS. Nonsparking tools must be used in spaces where fuel with a minimum flash point of less than 140° F (60° C) is stored or handled. Gasoline has a flashpoint of approximately -45° F (-43° C); therefore, spark resistant tools are mandatory in gasoline hazardous areas. Such tools are made of beryllium copper or aluminum alloys and do not wear well. Therefore, their use is restricted to hazardous areas. They shall not be used indiscriminately in nonhazardous locations.

542-3.8.2 FILTER ELEMENTS. A filter separator may be installed and operational in some gasoline systems. Typical filter separators are equipped with two types of elements: (1) coalescer elements and (2) separator elements. Water in the fuel does not affect the performance of the coalescer elements as compared to solids contamination. Coalescer elements can collect only a limited amount of solids before adversely affecting the performance of the filter separator unit. Adherence to established preventive maintenance procedures prevent fuel contamination by coalescer element renewal and separator element inspections. Refer to paragraph [542-6.2.4.1](#) for replacement requirements.

542-3.8.3 COFFERDAM AND DOUBLE-WALL PIPE INERTING. Charge the cofferdam or tank compartment surrounding the gasoline tank at all times with an inert gas. Check the cofferdam daily with the appropriate inertness test equipment to determine the percentage of inertness. (refer to paragraph [542-2.8.1](#) for a descrip-

tion of inertness test equipment.) Percent inertness is the percent reduction of oxygen in the space. For example, 50 percent inertness indicates that air in the space contains about 10.5 percent oxygen, or half the normal 21 percent. With nitrogen, a reading of at least 50 percent is required. If CO₂ is used for inerting, a reading of at least 35 percent is required. A pressure gage is installed for monitoring inert gas pressure in double-wall piping. Check the gage daily for normal operating pressure.

542-3.8.4 HOUSEKEEPING. Proper maintenance and cleanliness (housekeeping) cannot be overstressed. Deal immediately with minor gasoline system difficulties. Leaks, spillage, malfunctioning equipment, contaminated fuel, and poorly kept records are dangerous.

542-3.8.5 MOGAS FUEL SAMPLING AND TESTING. Refer to [Table 542-7-1](#) for MOGAS sampling and testing requirements.

542-3.9 MOGAS SYSTEM PRESSURE TESTING

542-3.9.1 GENERAL. The following quality assurance (QA) tests are normally performed by the contractor or shipyard, following repairs that require welded joints. Ship's force is required to witness all QA functions.

542-3.9.2 AIR AND SF₆ REFRIGERANT TEST OF STORAGE TANKS. The draw off tank, cofferdam and outer gasoline storage tank, with the sluice lines blanked off, shall be subjected to an independent 10 psig air and SF₆ refrigerant test. The amount of SF₆ refrigerant required for air and SF₆ tests is one ounce by weight of SF₆ for each 30 cubic feet of enclosed space. During a period of 10 minutes there shall be no pressure drop. Remove blank flanges or plugs after test.

542-3.9.3 HYDROSTATIC TEST OF STORAGE TANKS. Fill the drawoff tank and the outer gasoline storage tank with filtered freshwater, with the sluice lines unobstructed. Hydrostatically test tanks as a unit to the specified design head. Maintain pressure for at least 30 minutes; tanks pass the test if there is no evidence of leakage, weeping, or drop in pressure.

542-3.9.4 HYDROSTATIC TEST OF MOGAS AND SEAWATER PIPING. After installation, hydrostatically test MOGAS and seawater piping to 135 percent of system design pressure, or perform tightness test option in accordance with **NSTM Chapter 505, Piping Systems**. Before the test, flush the system in accordance with **NSTM Chapter 505**. Flushing water can be used to pressurize the system to the hydrostatic test pressure required. Isolate the gasoline pumps and the filter separator (if installed) from the system. Test the seawater piping up to the overboard discharge connection.

542-3.9.5 AIR AND SF₆ TEST OF MOGAS AND SEAWATER PIPING. Upon completion of the hydrostatic tests, test the MOGAS and seawater piping, including the filter separator (if installed) but excluding the pumps and sluice piping, with air and SF₆ refrigerant, and correct all leaks. Keep the tank manhole access openings to the MOGAS tank open during these tests to protect the tanks. Blank the seawater overboard discharge line. Initially test piping with the filters isolated from the system. Pressurize to the system design pressure, but not less than 50 psig. Build up test pressure gradually and hold long enough to permit examination of all the piping system joints with a halogen electronic leak detector (preferred method), a halide torch, or other approved detector. Drop the air and SF₆ pressure to 30 psig, and test the filter separator (if installed). Check for leaks. Open closures in the seawater overboard discharge line after completion of the test.

542-3.9.6 DRY CLEANING SOLVENT OR JP-5 HYDROSTATIC TEST OF MOGAS PIPING. After completion of the foregoing tests, hydrostatically test the MOGAS system (including gasoline pumps, tanks, and filter separator, if installed) with either dry cleaning solvent MIL-PRF-680, Type III, or JP-5. Before starting the test, inert the cofferdams to 8 psi. Fill storage tanks with clean freshwater. Displace the water by introducing a test fluid by way of the draw off tank. Test the system (including the gasoline pumps and filter separator, if installed) on the discharge side of the draw off tank cutout valves to 135 percent of system design pressure but not less than 50 psig. Test the remainder of the system, including the tanks, to a pressure equal to the specified design head. Hold pressure long enough to permit examination of all tanks and piping, but for at least 6 hours. During this time, the entire system fails the test if it is not absolutely tight.

542-3.9.7 OPERATIONAL TEST OF MOGAS SYSTEM. While at sea, give the MOGAS system an operational test with the test fluid, as follows:

1. Check the liquid level indicating gages for accuracy and adjust for true readings.
2. Check the rate of delivery at the MOGAS fueling station.
3. Test the accessibility of steaming-out connections and fittings by connecting the steam supply hose to steam inlets of the MOGAS systems. The steam shall not be turned on.
4. After all tests, remove the test fluid from the system.

542-3.9.8 STORAGE TANK FLUSH. After completion of all tests, flush the storage tanks for at least 3 complete volume changes with clean seawater before initial filling with gasoline. Do the flushing operation in deep water, free of mud and sea growths.

542-3.9.9 ADDITIONAL TESTING INFORMATION. refer to **NSTM Chapter 505, Piping Systems**. for test intervals, testing of removed and refurbished piping system components, requirements for remade mechanical joint or modified piping where hydrostatic testing is impractical, tightness test at operating pressure in lieu of hydrostatic test, test precautions, and inspection requirements.

SECTION 4

JP-5 SYSTEMS (AVIATION AND AIR CAPABLE TYPE SHIPS)

542-4.1 PRINCIPLES OF JP-5 SYSTEMS

542-4.1.1 SHIP TYPE. Shipboard JP-5 fuel systems are provided primarily to dispense fuel to aircraft. Ships that dispense fuel to aircraft can be categorized into two types: aviation and air capable.

542-4.1.1.1 Aviation Type Ships. Aviation ships are ships whose primary mission is the support of fixed and rotary wing aircraft. Carriers (CV and CVN), which primarily support fixed wing aircraft, and amphibious ships (LHA, LHD and LPD), which primarily support rotary wing aircraft, are aviation ships.

542-4.1.1.2 Air Capable Type Ships. Air capable ships, in this context, are ships whose primary mission is other than the support of aircraft, but which are equipped with JP-5 systems for on-deck rotary wing aircraft fueling or helicopter in-flight refueling (HIFR). Air capable ships are not designed to operate with fixed wing aircraft. Ships such as cruisers, destroyers, frigates, LSDs, and others are air capable ships.

542-4.1.1.3 JP-5. JP-5 systems for aviation ships are more complex and extensive than those for air capable ships; therefore, [Section 4](#) will provide separate discussions for aviation ship JP-5 systems and air capable ship JP-5 systems.

542-4.1.2 JP-5 SYSTEM PRIMARY FUNCTION. The primary function of the JP-5 system is to provide aircraft with proper quality aviation turbine fuel at specified delivery rates. To ensure that high-quality fuel is delivered to the aircraft, two independent stages of purification and handling are provided. Depending on the ship type, JP-5 from storage tank(s) is delivered to service tanks via centrifugal purifiers or transfer filter separators, or "Transfer filters". The second stage of purification occurs between the service tank(s) and the aircraft refueling stations. Service filter separators, or "Service filters", are used as the second cleaning stage where service fuel is delivered from the service tank(s) to aircraft via service filter separators. In addition, tanks are coated, and piping, in most cases, is non-ferrous. New construction ships may utilize stainless steel, CRES 316, as the piping material in efforts to reduce copper leaching in the fuel path over periods of time. Stripping systems are furnished to remove settled contaminants, such as water or sludge, from the bottoms of JP-5 tanks.

542-4.1.3 OTHER JET FUELS PROHIBITED IN JP-5 SYSTEMS. JP-4 and JP-8 are aviation turbine fuels used by the United States Air Force and Army. Jet A-1 and Jet A fuels are used commercially. These other aviation turbine fuels all have flashpoints significantly lower than the minimum 140° F of JP-5, and would dangerously lower the flashpoint of JP-5 if defueled into the ship's JP-5 system, or drained into any other shipboard system, such as an oily waste system. Navy and Marine Corps aircraft are sometimes fueled at land-based stations or through in-flight tanking with these low-flashpoint fuels. A flashpoint test shall be conducted on fuel extracted from aircraft low-point drains before defueling. Aircraft with fuel having a flashpoint less than 140oF shall not be defueled into ship's JP-5 system, or drained into any other shipboard system, such as an oily waste system. Use of the aircraft-to-aircraft transfer cart is recommended, if installed, to handle low flashpoint fuels. Additional requirements for handling lower flashpoint fuels are covered in NAVAIR 00-80T-1 **Aircraft Refueling NATOPS Manual**.

542-4.1.3.1 Aviation Turbine Fuel Thermal Stability Additive The United States Air Force (USAF) utilizes an aviation turbine fuel thermal stability additive, commonly referred to as "+100". The additive is designed to

increase the thermal stability of aviation turbine fuel by 100° F. The +100 additive is considered a dispersant or detergent. The additive has detrimental affects to shipboard systems, which include:

- a. Tendency to disarm the filter separator coalescer elements used in aviation turbine fuel purification systems. Filter separator coalescer elements, which come in contact with the +100 additive, lose their ability to coalesce water, allowing the passage of water and fine sediment contaminants downstream of the filter separator unit.
- b. Affects the ability of the centrifugal purifiers to effectively separate water and sediment from the aviation turbine fuel.
- c. Detergent effect of the additive may clean tank and piping surfaces causing a potential in sediment during initial use.
- d. The presence of the +100 additive makes readings taken with the AEL Free Water Detector (FWD), a component of the combined contaminated fuel detector (CCFD), unreliable.

Currently, the USAF and several allied countries utilize the +100 additive in JP-8, and re-designates this fuel as JP-8+100 (F-37). USAF and Navy commands have established policies and protocols to avoid inadvertent refueling of shipboard naval aircraft using JP-8+100. With the additive only being used in JP-8, low flashpoint handling, as outlined in paragraph 542-4.1.3, shall be followed.

542-4.1.4 JP-5 SYSTEMS. JP-5 systems consist of various systems, depending on ship type and class.

542-4.1.4.1 All JP-5 systems are composed of the following systems:

- a. Receiving (filling) and transfer system
- b. Stripping system
- c. Service (fueling and defueling) system

542-4.1.4.2 Depending on ship class, any or all of the following additional systems may be provided on aviation ships:

- a. Ballast system
- b. Auxiliary JP-5 system
- c. Jet engine test facility fuel system
- d. Reclamation system

542-4.1.5 Ship capability for pumping, transferring, and stripping JP-5 is limited by the number and capacities of pumps, filter separators or purifiers, and system design. The JP-5 systems installed on CV, CVN, LHA, LHD and LPD ships have large storage capacity, multiple aircraft fueling stations, and multiple pumps and filtering equipment.

542-4.1.6 The JP-5 systems on air capable ships have less storage capacity, one or two service tanks, and a minimal number of pumps and filters.

542-4.2 AVIATION SHIP JP-5 SYSTEM DESCRIPTION

542-4.2.1 JP-5 TANKS. Various types of tanks are used for the storage of JP-5 onboard ships.

- a. JP-5 storage tanks are used for the storage of JP-5 received from the filling and transfer system.
- b. JP-5 storage or ballast tanks are used to selectively store JP-5 received from the filling and transfer system, or seawater from the ballasting system.
- c. JP-5 overflow tanks store JP-5 received from the filling and transfer system and overflow from tanks that have not been provided with independent overflows. In a standpipe type configuration, overflow tanks remain normally empty and receive fuel via the standpipe when an overflow condition occurs. These dedicated overflow tanks overflow directly overboard.
- d. JP-5 overflow or ballast tanks store JP-5 received from the filling and transfer system and overflow from tanks that have not been provided with independent overflows. Also, these tanks are used for selected storage of JP-5 or seawater received from the ballasting system.
- e. Contaminated JP-5 settling tanks receive contaminated JP-5 from the stripping system and from the fueling-at-sea flushing connections. These tanks facilitate the separation and removal of usable JP-5 from non-burnable liquids and solid contaminants.
- f. JP-5 defuel tanks receive fuel from aircraft or aircraft refueling stations by the defuel piping system, or via the filling and transfer main.
- g. JP-5 service tanks receive purified JP-5 from the transfer system for delivery to the service systems.
- h. Drain and sump tanks receive fuel or water and fuel mixture during normal operations and maintenance.

542-4.2.1.1 JP-5 Tank Overflows. The JP-5 storage tanks and the JP-5 storage or ballast tanks are associated with specific overflow tanks. Each overflow tank is arranged to take the overflow from a group of storage tanks. The JP-5 storage and JP-5 storage or ballast tanks are equipped with overflow piping and one-way check valves to prevent backflow from the associated overflow tank. Overflow lines from the overflow, contaminated settling, and service tanks are normally fitted with a check valve to prevent seawater from flowing back into the tanks. In a standpipe type configuration, overflow tanks remain normally empty and receive fuel via the standpipe when an overflow condition occurs. These dedicated overflow tanks overflow directly overboard and are also equipped with a check valve to prevent seawater from flowing back into the overflow tank. In the event of overboard discharge from the overflow tank, report the incident and clean up in accordance with OPNAVINST 5090.1 and **NSTM Chapter 593, Pollution Control**.

542-4.2.1.2 JP-5 Tank Sounding Tubes and Air Escape Piping. Each JP-5 tank has a sounding tube for volume measurement and sampling. The sounding tube in most cases is perforated so that the fuel level in the tube is the same as in the tank. Sounding tubes are equipped with takedown joints to facilitate removal of broken tapes or bobs. Sounding tube caps are drilled to permit equalization of pressure prior to cap removal. Each tank is fitted with air escapes terminating to a common flame arrestor for tank venting during filling and emptying.

542-4.2.1.3 JP-5 Tank Level Indicators. Tank level indicators (TLIs) are used to provide information on the amount of fuel in tanks. Most ships are equipped with TLIs in all JP-5 storage, service, and contaminated tanks. Older ships may only be equipped with TLIs in JP-5 storage overflow, service and contaminated tanks. There are three types of TLIs that may be observed on ships. First, the pneumatic, static head design, liquid level indicating systems in accordance with NAVSHIPS Dwg 810-1385847 may be found on older ships. Gages used in this

configuration are calibrated with JP-5 having a specific gravity of 0.816. Typically, these types of TLIs are usually scheduled for replacement with one of the other forms of TLIs. Second, an electric TLI system (MIL-L-23886) utilizes a magnetic float (MF) sensing technique. The MF floats on the surface of the liquid level and travels on a transmitting rod with the rise or fall of the liquid. The level at which the MF is located is used to equate the capacity through a calibrated TLI meter. For JP-5 contamination tanks, the tanks are typically equipped with two indicating systems, one to show JP-5 and air interface and one to show JP-5 and water interface. The third type of TLI is the sounding tube pulse radar unit. A sounding tube pulse radar unit is installed at the top of a tank's sounding tube. The radar unit transmits signals down the sounding tube, where the signal reflects off of the top of the liquid level and returns to a receiver integral with the radar unit. The radar unit software uses the time required for the signal to travel to the level surface and return to calculate the level in the tank. The software then equates the sounding level to gallons and provides tank level data to output source, such as a meter, digital display or computer. Overflow tank indicators should be clearly marked to indicate the tanks from which they receive overflows.

CAUTION

Do not fill overflow tanks (service, storage, or contamination) above 80 percent level in port, except overflow tanks in a standpipe configuration. At sea, do not fill overflow tanks (service, storage, or contamination) above 95 percent, except overflow tanks in a standpipe configuration. If entering port with tank levels exceeding 80 percent, do not attempt to lower the tank(s) level to the 80 percent level for the affected tanks. Fuel movement in port should be minimized to avoid inadvertent fuel discharges overboard. For overflow tanks in a standpipe configuration, the overflow tanks must remain empty and all associated tanks utilizing the standpipe as the means to overflow may be filled to 95 percent level in port and at sea.

542-4.2.1.4 JP-5 Tank Level Alarms. A high-level audible and visual alarm is provided with the tank liquid level indicator for tanks overflowing overboard. For contaminated JP-5 settling tanks, the alarm is provided only for JP-5 and air interface indicator. Dependent upon the ship, the tank level indicators and alarms may be located at respective tank manifolds or cutout valves, pump rooms, fuel control space or control consoles. High-level alarms are set to actuate at a point between 95 and 98 percent of tank capacity to provide an approximate 2-minute warning before overflow occurs when the tank is being filled at its design fill rate. In the standpipe configuration, the overflow tanks have low level and high level alarms, at 5 and 95 percent, respectively. Additionally, to prevent overflow, the standpipe liquid level is monitored. Drain and sump tanks may have a float type or sounding tube radar type alarm system. Both systems activate an audible alarm at 60 percent capacity.

542-4.2.1.5 JP-5 Tank Coating. All JP-5 tanks must be coated. See the surface preparation and painting section in **NSTM Chapter 631, Preservation of Ships in Service**, for tank coating requirements.

542-4.2.1.6 JP-5 Tank Cleaning. Periodic JP-5 tank cleaning promotes safe fuel handling by identifying and/or removing sediment accumulation or microbiological growth. Planned Maintenance System (PMS) procedures are established to provide guidance on the frequency and procedures for tank cleaning. Deposits within the tanks are washed away easily by utilizing a fire hose with seawater. Wash water can be removed from the storage tanks that have ballast capability by the main drainage eductors and from the service tanks and non-ballast type tanks by the motor-driven stripping pumps. Portable drainage pumps can be used to complete removal of water. The danger of damaging the tank coating prohibits steaming out. Port Engineers, ships or Type Commanders are to

insure tanks are cleaned in accordance with the appropriate Class Maintenance Plan (CMP), Integrated Class Maintenance Plan (ICMP) or the applicable Tank and Void Program.

542-4.2.2 AVIATION SHIP JP-5 STRIPPING SYSTEM. Stripping systems are provided for removing water and sludge from the bottoms of all storage tanks and service tanks. The stripping system is also used to remove residual JP-5 below the tank's fill and transfer tailpipe for consolidation purposes. A cross-connect between the storage stripping and service stripping systems provides for service tank stripping when the motor-driven stripping pump is used during tank-cleaning operation. The storage stripping system shall not be cross-connected to the service system unless fitted with a pipe blind (also called spectacle flange) or locked closed valve. Either shall remain normally closed unless cleaning service tanks.

542-4.2.2.1 Motorized Pump Stripping for Storage Tanks. A stripping system is provided for all storage tanks containing JP-5. Motor-driven stripping pumps located in each JP-5 pump room take suction from the main in each tank group, and discharge through a stop-check valve to the contaminated JP-5 settling tank. The stripping pump discharge has a sight glass and a test connection. The stripping systems in forward and aft JP-5 pump rooms are not cross-connected. Each stripping system discharge main, forward and aft, is connected to the transfer main for consolidation of JP-5 remaining in storage tanks beneath the suction tailpipes.

542-4.2.2.2 Stripping Systems for Service Tanks. A JP-5 service stripping system is provided for stripping JP-5 service tanks. The JP-5 service stripping contains either a hand stripping pump or a dedicated motor-driven stripping pump. The system consists of a stripping line containing a cutout valve, which terminates in a non-vortex bell mouth fitting (without splash plate) at the lowest point of the JP-5 service tank bottoms. The lines from each service tank are combined into a common suction header. A hand or motor-driven stripping pump, sight glass, test sample connection, check valve, and cutout valve are installed in that order downstream from the JP-5 service tank cutout valve in the JP-5 pump room. A globe stop check valve is sometimes installed in lieu of the check valve and cutout valve. The stripping pump discharges to the contaminated JP-5 settling or purifier drain tank.

542-4.2.3 AVIATION SHIP JP-5 FILLING AND TRANSFER SYSTEM. A transfer system consists of transfer pumps, centrifugal purifiers or filter separators, and piping that permits the transfer pumps to take suction from storage tanks in one tank group and distribute to other storage tanks in other tank groups and to service tanks via the centrifugal purifiers or filter separators. The purposes of the filling and transfer system are listed below.

- a. For filling the storage tanks
- b. To transfer from storage tanks through a purifier or transfer filter separator, or "Transfer filter", to the service tanks
- c. To transfer from port to starboard, starboard to port, forward to aft, aft to forward, and, in emergencies, to change the list or trim of the ship
- d. To transfer to the ship propulsion system for use as propulsion fuel
- e. To consolidate

542-4.2.3.1 Fueling-at-Sea (FAS) Connections. Filling connections begin with a stop valve and a 90 -degree elbow. The elbow has a 6- or 8-inch flange, dimensioned and drilled for connecting to the receiving equipment. The elbow has a 1/4-inch test valve and a pressure gage. In several instances, a connection is available for use of a portable gage in lieu of a permanently installed pressure gage. A flushing line is installed outboard of the fill connection stop valve on some carrier and amphibious aviation type ships. It is used for hose flushing and to

receive the initial flow during FAS, and is directed to the contaminated JP-5 settling tanks (or designated JP-5 storage tanks) directly or through the defueling main. JP-5 filling connections are connected to a filling main. The filling main directs the fuel to the JP-5 storage, storage or ballast, and overflow tanks. Valves are provided in the main between the points of connection of the filling lines and the main to permit main segregation. The system is sized so that the design filling rate can be achieved with 40 psig pressure at the filling connection.

542-4.2.3.2 JP-5 Transfer Pumps. Electric motor-driven, positive displacement (such as rotary vane, rotary gear, or rotary screw) pumps are normally used for transferring JP-5. On new construction ships, such as CVN-77, a two-speed, positive displacement transfer pump is used to combine the functions of JP-5 transfer and JP-5 stripping operations via the use of one pump.

542-4.2.3.3 JP-5 Transfer Filter Separator. Most aviation ships have centrifugal purifiers, but air capable ships and LPDs have a transfer filter separator, MIL-PRF-15618, installed in the pump room. The transfer filter separator is equipped with a vent and a drain for accumulated water to the contaminated drain tank. Typically, the drain is configured for automatic and manual operation.

542-4.2.3.4 JP-5 Purifiers. The transfer system in each pump room has two 200 or 300 gpm centrifugal purifiers, MIL-P-22088. One transfer pump supplies one centrifugal purifier. Waste discharges from the purifier bowl to purifier drain tanks. The casing drain and bowl drain for each purifier discharge to these drain tanks independently. No manual valves shall be installed in these lines.

542-4.2.4 AVIATION SHIP JP-5 SERVICE SYSTEM. The purpose of the service system is to deliver clean, bright, and sediment-free fuel to aircraft fueling stations from the service tanks through the service filter separator. The system consists of service tanks, pumps, filter separator, distribution piping, and aircraft fueling stations with hoses, hose reels, and fueling nozzles.

542-4.2.4.1 JP-5 Service Tanks. Service tanks are fitted with a filling line, a service pump suction line, an air escape, a sounding tube, a service pump recirculating line, an overflow line, two stripping lines, and a remote-reading liquid level indicator.

542-4.2.4.2 JP-5 Service Pumps. The JP-5 service pumps are centrifugal, and have a 5 percent recirculating line with an orifice and a stop-check valve. A warning plate is installed at the pump inscribed: **Valve must be open before starting pump**. The centrifugal pumps used in the service system are not self-priming and cannot pump air; therefore, an air eliminator is installed on some ships where necessary. The air eliminator ensures that the pump casings are filled with JP-5 by removing air and fuel vapors from them before starting the pump.

542-4.2.4.3 JP-5 Service Filter Separator. The pump room JP-5 service system risers have a filter separator, MIL-PRF-15618, Class 1. Depending on the ship, the filter separators may be located in specifically designated filter rooms, at the fueling stations, or in the pump room. The filter separator is installed with a bypass, vent, sump drain to drain tank or contaminated JP-5 settling tank, manual and automatic sump drain (water) or to contaminated JP-5 settling tank, and an automatic shutoff valve at the filter outlet to prevent delivery of water to the fueling stations. Some older ships may still contain drain or vent piping leading overboard. Facilities are provided for the removal and lowering of the filter heads, or manhole covers, in order to facilitate replacing filter elements.

542-4.2.4.4 JP-5 Service System Piping. In each pump room on CV/CVN, LHA, and LHD ships, service pumps take suction from the JP-5 service tanks and discharge via port and starboard riser lines to filter separa-

tors. The distribution piping consists of a loop formed by cross-connecting port and starboard and forward and aft filters at the discharge side of the filters so that any service pump can serve any aircraft fueling station.

542-4.2.4.4.1 JP-5 service piping is arranged, and valves provided, so that the system can be segregated into independent systems, each serving a quadrant of the ship. The piping is sized by ship's class so that each riser can convey the specified quantity of JP-5 to the fueling stations in that quadrant of the ship. The riser, mains, and branches are designed for the required delivery capacity per hose with a minimum pressure of 30-45 psig at the hose nozzle of the most remote fueling station.

542-4.2.4.4.2 Cross-connections with pipe blinds (also called spectacle flanges) are provided between the service pump suction main and the transfer pump suction main, and between the service pump discharge main and the transfer pump discharge main, to permit the use of service pumps for off loading JP-5, or cargo fuel operations.

542-4.2.4.4.3 JP-5 service piping on LPD ships is supplied from a single pump room.

542-4.2.4.5 JP-5 Fueling Station. A number of flight deck and hangar deck fueling stations are provided for fueling and defueling aircraft.

542-4.2.4.5.1 JP-5 CLA-VAL Valve and Defueling Pump. Each CLA-VAL type JP-5 aircraft fueling station is provided with a fuel-defuel valve and a defueling pump. The defueling pump is a motor-driven, constant-speed, positive-displacement, vane-type pump. The CLA-VAL fuel-defuel valve has two operating modes. In the fuel mode, it delivers JP-5 to the fueling hose. A pressure reducing feature built into the valve regulates downstream pressure at the nozzle to 45 psig gage. In the defuel mode, the valve connects the fueling hose to the JP-5 defueling pump suction. The JP-5 defueling pump takes suction from the fueling station fuel-defuel valve adjacent to the hose reel inlet and discharges to the JP-5 defueling main, which is independent of the JP-5 service main. A vacuum pressure gage is installed between the hose reel and the fueling-defueling valve. The JP-5 defueling main conveys the JP-5 from the aircraft fueling station back to the JP-5 transfer system and an available JP-5 storage tank, defuel tank, or contaminated settling tank.

542-4.2.4.5.2 JP-5 Hoses, Hose Reels, and Nozzles. JP-5 refueling stations aboard aviation type ships are equipped with either 2-1/2 inch collapsible hose assemblies for refueling aircraft or 1-1/2 inch non-collapsible hose assemblies for defuel operations. The hoses used, both 2-1/2 inch collapsible and the 1-1/2 inch non-collapsible, are constructed to MIL-H-17902. A hose assembly consists of hoses, hose couplings, hose continuity spider assemblies and continuity (or control) wire). A quick disconnect coupling (QDC) is installed between the last hose and the refueling nozzle. The QDC used may be a standard bronze coupling type (per MIL-C-19179, Class 2) or the aluminum constructed dry break coupling (per MIL-C-24788). The MIL-C-19179 QDC is no longer supplied by the supply system. In-service MIL-C-19179 QDCs are not required to be replaced for the installation of a dry break QDC unless material integrity and operation dictate replacement. The dry break QDC is equipped with an integral strainer, which negates the necessity of the nozzle strainer typically located at the nipple, and provides easy accessibility for routine maintenance. The bronze QDC assembly does not include an integral strainer. When using the bronze QDC, the nozzle strainer is located in the nipple used to mate to the single point pressure, D-1 nozzle. The flanged nipple is used for pressure refueling nozzles. 2-1/2 inch pressure nozzles are constructed per SAE AS5877. Threaded nipples are used for mating with gravity type nozzles. 1-1/2 inch gravity nozzles are constructed per MIL-N-87963. Hose reels, per MIL-R-15917, are used to hold the hose assemblies with QDC and nozzle.

542-4.2.4.5.3 JP-5 Hose Flushing Connections. A connection is provided at each aircraft fueling station for flushing the service system piping and fueling hoses, via the defueling main prior to fueling aircraft. A warning plate is provided at the station stating: **Hoses are to be flushed until an acceptable sample is obtained prior to fueling aircraft.** A warning plate located on a fueling station may be considered a Foreign Object Damage (FOD) item. An alternative means of conveying the intent is stenciling the warning on a bulkhead in the fueling station. Refer to [Table 542-7-1](#) for sampling requirements.

NOTE

Fixed eductors and associated piping and valves up to the manifolds are the responsibility of the ships Engineering Department. This includes preventive and corrective maintenance.

542-4.2.5 AVIATION SHIP JP-5 BALLAST SYSTEM. To provide stability for the ship and to preserve the integrity of the underwater and side protection systems, certain JP-5 tanks can be ballasted with seawater when empty of JP-5. These tanks are provided with ballast/deballast tailpipes connected to the ship's ballast/deballast system. These tailpipes are also used for tank stripping. Cutout valves are installed in the transfer lines connected to the JP-5 storage or ballast tanks, and have a locking bar and warning plate inscribed: **Valves must be locked closed when tank is flooded with seawater.**

542-4.2.6 AVIATION SHIP JP-5 AUXILIARY SERVICE SYSTEM. The JP-5 auxiliary service system installed on CV/CVN, LHA and LHD type ships delivers JP-5 service fuel to emergency diesel generators, auxiliary boilers, incinerators, small boat filling stations, or combat vehicle/support equipment filling stations.

542-4.2.7 AVIATION SHIP JP-5 JET ENGINE TEST SYSTEM. This system provides JP-5 service fuel to the Jet Engine Test Facility located on the fantail of aircraft carriers. Some systems are provided with a dedicated pump and filter separator to deliver JP-5 service fuel to the Jet Engine Test stand. Other ships provide JP-5 service fuel from the aft filter separator cross connection piping. The system is provided with a return line from the service stand to permit operating jet engines at various flow rates. The maximum flow is 200 gpm with unloading valve set to maintain 50 psig under all flow conditions. A solenoid-operated shutoff valve is provided, for emergency use, to secure fuel flow from jet test filter separator. The solenoid-operated shutoff valve is also provided in the configuration where service fuel is delivered via the aft JP-5 service filter separators. The emergency shutoff control switch is located inside the jet engine test facility control booth.

542-4.2.8 AVIATION SHIP JP-5 RECLAMATION SYSTEM. The JP-5 reclamation system is designed to reclaim usable fuel from the JP-5 contamination tanks. The JP-5 contamination tanks receive fuel from hose flushing operations, JP-5 tank stripping operations, and the initial flow during an Underway Replenishment (UNREP or fueling-at-sea, FAS). The water and sediment received from the foregoing operations are permitted to settle out in the contaminated JP-5 settling tanks. The JP-5 transfer pump is used to draw suction from the JP-5 contamination tank and deliver the fuel to the reclamation pre-filter and filter separator (MIL-F-15618). Fuel is discharged through the reclamation filter separator and directed to the JP-5 storage tanks. The intent of the pre-filter unit is to entrap heavy sediment and avoid premature reclamation filter separator coalescer element clogging. Some new construction ships may be designed without a pre-filter.

542-4.3 AVIATION SHIP JP-5 OPERATIONS

542-4.3.1 AFOSS AND SAFETY INFORMATION. Conduct JP-5 system operations under the direct supervision of the officer in charge. Only thoroughly trained, PQS-qualified personnel shall operate the JP-5 system.

Non-PQS qualified personnel shall be under direct control of a qualified operator. See dangers listed in paragraphs 542-2.3 and 542-2.4, and precautions throughout Section 2. Schedule fuel system operations to rotate tanks and pumps. Perform operations in accordance with the Aviation Fuel Operational Sequencing System (AFOSS) when installed. refer to Table 542-4-1 for a summary of basic JP-5 operations.

Table 542-4-1. AVIATION SHIP BASIC JP-5 OPERATIONS

Operation	Drawn From	Deliver To	Pumps Used
Filling Tanks (FAS)	Deck Fill Connections	Storage tanks	None
Transferring	Storage tanks	Service tanks	Transfer pumps via purifiers or transfer filter separators
Transferring (FAS) (refer to paragraph 542-4.3.4.3)	Service tanks	Ships in company	Service pumps
Fueling aircraft	Service tanks	Aircraft	Service pumps via service filter separators
Defueling aircraft	Aircraft	Storage, defuel, or contaminated settling tanks	Defueling pump
Offloading	Storage or service tanks	Deck fill connections	Transfer or service pumps
Stripping	Storage or service tanks	Contaminated settling tank	Storage motor stripping pumps, transfer/stripping pumps (2-speed), service hand or motor stripping pumps
Ballasting	Firemain	Storage or ballast tanks	Fire pumps
Deballasting	Storage or ballast tanks	Storage tanks	Main drainage eductor
Reclamation	Contaminated settling tanks	Storage tanks	Transfer or stripping pumps (via reclamation system pre-filter, if installed, and filter separator)
Emergency fuel to boilers	Storage or service tanks	Ship's fuel service tanks	Transfer pumps

CAUTION

Do not fill overflow tanks (service, storage, or contamination) above 80 percent level in port, except overflow tanks in a standpipe configuration. At sea, do not fill overflow tanks (service, storage, or contamination) above 95 percent, except overflow tanks in a standpipe configuration. If entering port with tank levels exceeding 80 percent, do not attempt to lower the tank(s) level to the 80 percent level for the affected tanks. Fuel movement in port should be minimized to avoid inadvertent fuel discharges overboard. For overflow tanks in a standpipe configuration, the overflow tanks must remain empty and all associated tanks utilizing the standpipe as the means to overflow may be filled to 95 percent level in port and at sea.

542-4.3.2 RECEIVING JP-5 ON AVIATION SHIPS. If JP-5 storage or ballast tanks have been ballasted, deballast and strip as dry as possible with the motor-driven stripping pumps before receiving JP-5 onboard. Ships planning to replenish in port shall deballast outside the prohibited zone (refer to paragraph 542-2.10.1) Discharge all strippings to a contaminated JP-5 settling tank or oily waste holding tank. Refuse fleet oiler or barge deliver-

ies if the JP-5 contains solids in excess of 10 milligrams per liter or if it is not clear and bright with no visible water. To be acceptable, JP-5 fuel must be clear and bright and contain no free water, in accordance with the free water visual test in paragraph 542-5.3.3, test f. A cloud, haze, specks of particulate matter, or free water indicates that the fuel is unsuitable and points to a breakdown in fuel handling equipment, fuel purification equipment, or procedures. Before and during receipt of JP-5 (every 15 minutes), samples are taken at all in-use deck fill connections in containers that permit visual fuel inspection. Discharge unacceptable JP-5 to the contaminated JP-5 settling tanks pending determination of acceptable quality via the hose flushing connection.

NOTE

The rated capacity of a JP-5 service or storage tank is 95 percent. The remaining 5 percent capacity is to account for JP-5 thermal expansion. Never fill fuel tanks to more than 95 percent of capacity. Double bottom tanks are to be filled to 80 percent. If double bottom tanks must be filled to 95 percent, reduce tanks to 80 percent as operations dictate.

542-4.3.3 AVIATION SHIP JP-5 STORAGE PROCEDURES. The storage period between receipt of JP-5 from a tanker or shore base and delivery to an embarked aircraft is a vital link in the purification process. This settling period, in addition to proper stripping, will minimize the load on other purification processes in the system.

542-4.3.3.1 Stripping of JP-5 Storage Tanks. Tanks are stripped until visual samples from the motorized stripping pump outlets are free from settled solids contamination and water. Stripped JP-5 is discharged to the contaminated settling tank. Stripping intervals are specified in paragraph 542-7.6.

CAUTION

Conduct ballasting of JP-5 tanks only when the integrity of the ship's underwater protection system necessitates. Adverse conditions such as damage to tank coatings, loss of fuel system icing inhibitor (FSII) by leaching, tank overpressurization or water contamination may result when tanks are ballasted. Ballasting or deballasting of JP-5 tanks prior to entering dry dock and repair facilities shall be avoided because of the foregoing adverse conditions and the potential for discharge of JP-5 into prohibited waters.

NOTE

Fixed eductors and associated piping and valves up to the manifolds are the responsibility of the ships Engineering Department. This includes preventive and corrective maintenance.

542-4.3.3.2 Ballasting and Debballasting JP-5 Storage or Ballast Tanks. The ballast system, which is maintained and normally operated by the engineering department, allows for flooding selected JP-5 tanks with seawater via the firemain, ballast pumps, or directly from the sea; it also allows for drainage through the main drainage system. A common tailpipe is used for ballasting, debballasting, and stripping (through the JP-5 flood and drain manifold) of the storage or ballast tanks. Seawater ballast should be admitted only to tanks completely emptied of JP-5. After a tank has been ballasted, debballast and strip prior to refilling the tank with JP-5. The use of seawater ballasting to replace JP-5 in tanks will result in water contamination of the replacement JP-5. Sound the tanks

with water-indicating paste (NSN 6850-00-270-5526) MIL-W-83779, to ensure that tanks are water free before receiving JP-5. Ballasting instructions shall agree with the liquid loading instructions on Plate No. 1, Part II of the Damage Control Book for the specific ship.

542-4.3.4 AVIATION SHIP JP-5 TRANSFER SYSTEM OPERATION. During the transfer of JP-5 from storage to service tanks, take samples for visual examination from the transfer system centrifugal purifier or filter separator outlet at 15-minute intervals. Samples shall be clear and bright and contain no free water or particulate matter. Particulate matter or free water indicates that the fuel is probably unsuitable and points to a breakdown in the transfer filter separator or purifier equipment or operation. If visual samples fail to meet this test, secure transfer operations until the following steps are taken:

- a. Storage tanks concerned have been re-sampled for proper effluent and re-stripped, if required.
- b. Purifiers have been inspected for:
 - 1 Proper discharge ring
 - 2 Cleanliness
 - 3 Correct inlet and outlet pressures.
- c. Transfer filter separator elements have been replaced as necessary.

542-4.3.4.1 Consolidation and Settling. After a transfer operation, consolidate the remaining JP-5 in the JP-5 storage tanks used. Use the JP-5 motor-driven stripping pumps, taking suction through the stripping line in the storage tanks, and discharging to the transfer main, and then to a designated storage tank. Consolidated fuel shall have the maximum possible settling time before use.

WARNING

Once JP-5 is transferred to piping or tanks of any auxiliary user, such as to propulsion boilers, emergency diesel generators, or incinerators, regardless of shipboard departmental ownership, it shall not be taken back into the aviation JP-5 fuel system. This includes direct issue points and overflow/air escape piping from any auxiliary user tank(s). The issued JP-5 shall no longer be considered aviation grade fuel. The shipboard aviation fuel system is not equipped to process any potential commingled fuel in order to recreate aviation grade fuel, JP-5.

542-4.3.4.2 Emergency JP-5 Fuel to Boilers. In the event the ship's F-76 propulsion fuel supply has been depleted or otherwise becomes unusable, provision is made for providing JP-5 to the ship's fuel system. JP-5 is an acceptable substitute for F-76 fuel. The ship's fuel service tanks are filled with JP-5 by the transfer pumps, transfer main, and cross-connections between the JP-5 system and the ship's F-76 fuel system. The cross-connections are fitted with cutout valves and spectacle flanges that must be opened to allow for the transfer of JP-5 to the ship's F-76 fuel service tanks.

542-4.3.4.3 Replenishing Ships in Company. Replenishing ships in company shall provide JP-5 service fuel unless operational commitment dictates otherwise, in which case JP-5 storage fuel may be delivered. When JP-5 storage fuel is delivered, the JP-5 service system shall be thoroughly flushed upon completion of the replenishment operation.

542-4.3.5 AVIATION SHIP JP-5 SERVICE SYSTEM OPERATION. When performing any JP-5 service system operation, observe precautions in [Section 2](#).

542-4.3.5.1 Service System Startup. Basic startup procedures for the service system are:

1. Strip service tanks before each use.
2. Sample service tank fuel for analysis by ship's aviation fuel laboratory as required by [Table 542-7-1](#).

NOTE

No settling time is required for JP-5 service tanks.

3. Line up the service pump to take suction from the designated service tank and to discharge through the service filter separator to the aircraft fueling stations.
4. Line up the pump's recirculating line to permit recirculation to the tank from which suction is being taken. This line is sized, or equipped with an orifice, to prevent the pump from overheating during no-flow conditions. For CVN-68 Class ships, each JP-5 service tank suction valve is electrically related to the recirculation valve. Insure the tank recirculation valve opens with the opening on the designated JP-5 service tank, suction valve.
5. Line up the defueling piping from the aircraft fueling station defueling pump discharge to a slack JP-5 contaminated settling tank, JP-5 storage tank, or JP-5 defuel tank for aircraft fueling station operation.
6. Start the service pump with the discharge valve closed. When pump reaches rated discharge pressure, slowly open the discharge valve to build up pressure in the service system. Sudden, high-velocity flow causes hydraulic hammer, which shocks the service filter separator. Ensure that filter bypass valve is closed.

542-4.3.5.2 Service System General Operating Information. The following instructions should be observed during service system operation:

1. During fueling operations without installation of an in-line fuel quality sensor (Autogrape), sample for visual examination and conduct shipboard tests for solids contamination and free water. Take samples from service filter separator outlet and from each fueling station hose, refueling nozzle in accordance with [Table 542-7-1](#). Refer to [Table 542-7-1](#) for ships outfitted with in-line fuel quality sensors.
2. Stripping of service tanks is imperative to ensure that water contaminated fuel is not delivered to the aircraft. Stripping intervals are specified in paragraph [542-7.6](#).
3. Keep topside mains and risers full of JP-5 during all operating periods to prevent the formation of condensate. Secure the service pump discharge valves before securing the service pumps. After the topside mains and risers have been drained (such as during extended in-port periods or for maintenance), and before fueling aircraft, flush the affected quadrant(s) to remove condensation and particulate matter.
4. Sufficient discharge pressure is available from any service pump in either JP-5 pump room to supply JP-5 to any aircraft fueling station.

5. Gravity nozzles are rarely used for fueling aircraft. However, when fueling with gravity nozzle, be sure that the nozzle grounding wire (not required for pressure nozzles) is connected to aircraft metal before removing tank filler cap from aircraft.
6. After fueling, store hose on hose reel, or on a designated rack near the JP-5 delivery valve. Store hose to preclude damage or water entry.

542-4.3.5.3 JP-5 Fueling Station Operation. A solenoid control circuit allows the fueling-defueling valve to be put in the fueling or defueling position electrically. This is done by a manually controlled switch at the hose nozzle quick-disconnect coupling (QDC), by a high resistance ground, or by breaking the ground connection to the aircraft being fueled. A single insulated control wire is extended through the hose and hose reel from the nozzle QDC switch to the solenoid control. A magnetic amplifier (or solid state control), provided for each fuel-defuel valve, employs the small direct current to control a larger alternating current that actually activates and deactivates the solenoid-operated pilot valve. The control circuit is limited to a current of such low magnitude that circuit interruption cannot ignite fuel vapors.

542-4.3.5.4 Preparations for JP-5 Fueling and Defueling of Aircraft with Engines Off. Aircraft fueling and defueling is a continuous operation; all personnel involved must be thoroughly experienced in the operations and all safety precautions required. The following preparations and safety precautions shall be observed before fueling or defueling:

CAUTION

The fuel crew shall be constantly alert to maintain the cleanliness of the fueling area, as serious damage to an aircraft engine can result from foreign object damage (FOD).

1. The fueling and defueling crews shall be on station and in proper flight deck clothing, in accordance with NAVAIR 00-80T-109, **Aircraft Refueling NATOPS Manual** .
2. The refueling and receiving crew sound-powered phone talker shall maintain communication with flight deck control at all times during operations. Sound-powered telephone cords should be equipped with quick-disconnect (bayonet) plugs (NSN 5995-01-018-9807) to facilitate rapid breakaway without unscrewing the cord end plug from the bulkhead mounted jack box.
3. Plane captains shall be at their aircraft and aircraft engines stopped. Secure all electronic and electrical switches not required for fueling.
4. Make a mobile firefighting vehicle available to aircraft to be fueled, or a fueling crew member shall stand by with a portable PKP or CO₂ fire extinguisher. Make swabs and seawater available for cleaning up fuel spills.
5. Align the service system to take suction from a designated service tank and to discharge to the fueling stations via the service filter separator.
6. Align the defuel system to direct JP-5 from routine aircraft fueling station operation back to the defuel tank or a designated storage tank.

WARNING

JP-5 is flammable and can be dangerous to personnel.

542-4.3.5.5 JP-5 Fueling. If not sampled and tested (manually or via in-line fuel quality sensor) within a 24-hour period with acceptable fuel quality results, Each refueling hose (with nozzle) shall be flushed until a acceptable sample is obtained prior to fueling aircraft (refer to [Table 542-7-1](#)). Attach the nozzle to the fuel station flushing connection to flush back through defueling main to a JP-5 storage tank. Fueling procedures are as follows:

1. Unreel the hose and proceed to aircraft to be fueled.

NOTE

Ensure nozzle quick-disconnect coupling (QDC) switch is in OFF (defuel) position.

NOTE

Ground connections shall be made to bare metal.

2. Connect ground wire to metal deck and then to aircraft.
3. Remove refueling adapter cap from the aircraft.
4. Remove dust cover from the pressure fueling nozzle.
5. Lift nozzle by lifting handles; align the slots on the nozzle with the lugs on the aircraft adapter.
6. Press nozzle firmly onto adapter; ensure that all three nozzle lock keys are depressed.
7. Rotate nozzle clockwise to a positive stop.
8. Open station reel/riser valve.
9. Open defuel pump discharge valve.
10. Start defuel pump or station pump as applicable.
11. Place nozzle QDC switch in ON (fuel) position.
12. Fuel aircraft as directed by plane captain. Nozzle operator to confirm actuation of aircraft automatic fuel shutoff valve (as applicable) and check for leaks. If valve malfunctions, or leaks are detected, shut the nozzle and secure refueling until repairs are accomplished.
13. Rotate the nozzle flow control handle to the FULL OPEN position. The handle shall rotate 180 degrees to ensure that the poppet valve is fully open and locked.
14. When directed by plane captain, stop fueling aircraft. Shut the nozzle valve by rotating nozzle control handle 180 degrees to SHUT position.

NOTE

When the nozzle QDC switch is placed in the OFF position, the service station fuel/defuel CLA-VAL will automatically return to the defuel position and evacuate the hose.

15. Place nozzle QDC switch in OFF (defuel) position.
16. When the hose has completely collapsed, shut station riser valve.
17. Stop the defuel pump and shut the defuel pump discharge valve.
18. Disconnect nozzle from aircraft.
19. Replace refueling adapter cap on aircraft.
20. Replace dust cover on the pressure fueling nozzle.
21. Remove ground wire from aircraft, then from metal deck.
22. Restow hose.

NOTE

Do not drain back the JP-5 service system except for long periods of stand-down.

542-4.3.5.6 Refueling of Aircraft with Engines Operating (Hot Refueling). Preparations for aircraft hot refueling are the same as for normal refueling except as noted below:

1. Pilot selects fuel loading, ensures that the cockpit switches are in the proper positions, and maintains UHF radio contact with the tower.
2. Pilot secures all electronic and electrical equipment not required for refueling.
3. Pilot places all armament switches in the SAFE position.

NOTE

Aircraft shall be chocked and have initial tiedown prior to attaching ground wire and fueling nozzle. Canopy shall be closed.

4. Attach ground wire to metal deck, then to aircraft.
5. Nozzle operator attaches nozzle to the aircraft.
6. Plane captain then signals the nozzle operator to commence fueling. Nozzle operator to confirm actuation of aircraft automatic fuel shutoff valve (as applicable) and check for leaks. If valve malfunctions, or leaks are detected, shut the nozzle and secure refueling until repairs are accomplished.
7. Plane captain/aircrew shall check the vents for airflow unless the aircraft is equipped with a tank pressure gage or warning light.
8. When the required fuel has been added, the nozzle operator shuts off the fuel, evacuates the hose, and disconnects the nozzle.
9. Remove ground wire from the aircraft.
10. After all equipment is disconnected, the aircraft is ready for operations.

11. Restow all hoses.

542-4.3.5.7 Defueling JP-5. After making preparations shown in paragraph 542-4.3.5.4, proceed with JP-5 defueling as follows:

WARNING

Flash point shall be conducted on fuel extracted from aircraft low-point drains before defueling any aircraft. Aircraft with fuel having a flash point less than 140° F shall not be defueled into ship's JP-5 system, or drained into any other shipboard system, such as an oily waste system. Use of the aircraft-to-aircraft transfer cart is recommended, if installed, to handle low flash point fuel. Additional requirements for handling lower flash point fuels are covered in NAVAIR 00-80T-109, Aircraft Refueling NATOPS Manual . If required, defuel overboard where permitted by NSTM Chapter 593, Pollution Control .

1. Unreel the 1-1/2" non-collapsible hose and proceed to aircraft to be defueled.

NOTE

Ground connections shall be made to bare metal.

2. Connect ground wire to metal deck, then to aircraft.

NOTE

Ensure nozzle QDC switch is in OFF (defuel) position.

3. Remove refueling adapter cap from the aircraft.
4. Remove dust cover from the pressure fueling nozzle.
5. Lift nozzle by lifting handles and align the slots on the nozzle with the lugs on the aircraft adapter.
6. Press nozzle firmly onto adapter; ensure that all three nozzle lock keys are depressed.
7. Rotate nozzle clockwise to a positive stop.
8. Open the station defuel pump discharge valve.
9. Start defuel pump or station pump as applicable.
10. Place nozzle QDC switch to ON (fuel) position momentarily, then return nozzle ground switch to OFF (defuel) position.
11. Defuel aircraft as directed.
12. Rotate the nozzle flow control handle to the FULL OPEN position. (The handle shall rotate 180 degrees to ensure that the poppet valve is fully open and locked.)

13. When defueling is complete, shut the nozzle valve by rotating nozzle control handle 180 degrees to SHUT position.
14. When the hose has completely emptied, stop defuel pump and secure valves.
15. Disconnect nozzle from aircraft.
16. Replace refueling adapter cap on aircraft.
17. Replace dust cover on the pressure fueling nozzle.
18. Remove ground wire from aircraft, then from metal deck.
19. Restow hose.

542-4.3.6 AVIATION SHIP AUXILIARY SERVICE JP-5 SYSTEM. The auxiliary service JP-5 system installed on CV/CVN, LHA, and LHD ships provides for the delivery of fuel to emergency diesel generators, auxiliary boilers, small boat filling stations, incinerators, and combat vehicles and support equipment filling stations. The procedures for delivering JP-5 to the auxiliary transfer main is as follows:

1. Strip the selected service tank.
2. Open the tank valve from the JP-5 service tank selected and the cutout valve to the auxiliary service pump suction.
3. Make sure that the tank valves for service tanks not involved in the operations are closed.
4. Open the valves in the discharge line from the JP-5 auxiliary service pump to the distribution main.
5. Open valves in the JP-5 auxiliary service line to the stations to be serviced and check to determine that all valves in any branches not be used in the specific evolution are closed.
6. Establish communications between the pump room and the stations to be serviced.
7. Start the JP-5 auxiliary service pump.
8. When delivery operation is complete, secure the JP-5 auxiliary service pump and close all valves.

WARNING

If using service pumps to offload storage tanks, ensure the recirculation valve is closed. Leaving this valve open can lead to an inadvertent overboard discharge.

542-4.3.7 DELIVERING JP-5 OFF-SHIP. JP-5 is offloaded from service tanks by the service pumps. Storage tanks can be offloaded by transfer pumps or service pumps. It is essential that offloaded JP-5 be free of water and contaminants. To ensure this, offloading JP-5 shall not proceed until the following steps are taken:

1. Tanks to be offloaded have been stripped of water and contaminants before offloading in the same manner as is required before transfer from storage to service tanks.
2. JP-5 is determined acceptable by obtaining clear and bright samples from the stripping pump discharge for each tank to be offloaded.

3. System is aligned for offloading in accordance with AFOSS or the SIB.

542-4.4 AIR CAPABLE SHIP AVIATION JP-5 SYSTEM DESCRIPTIONS

542-4.4.1 INTRODUCTION. Many features of JP-5 systems are similar for both aviation ships and air capable ships. Paragraph 542-4.4, and its subparagraphs, address those specific features that are different for air capable ships.

542-4.4.1.1 System Functions. Air capable ship JP-5 fuel systems have fewer JP-5 storage and service tanks and a minimal number of pumps and filtering equipment, and are typically used for fueling helicopters. The JP-5 systems on air capable ships can be aligned to accomplish the following functions:

1. Receive and discharge JP-5 at deck filling connections and direct it to and from the storage tanks.
2. Deliver JP-5 from the storage tanks to the service tanks through a transfer pump and filter separator.
3. Deliver JP-5 from the service tanks to a fueling station via a service pump and service filter separator.
4. Strip JP-5 storage and service tanks through tailpipe(s) and pump(s) that are independent of all other fuel systems pumps and piping.

542-4.4.1.2 JP-5 Tanks and Tank Level Indicators. Tank level indicators (TLIs) are used to provide information on the amount of fuel in tanks. Most ships are equipped with TLIs in all JP-5 storage, service, and contaminated tanks. Older ships may only be equipped with TLIs in JP-5 storage overflow, service and contaminated tanks. Newer ships may be designed with a standpipe configuration, where the overflow tanks normally remain empty and tanks overflow into the overflow tank via a standpipe. There are three types of TLIs that may be observed on ships. First, the pneumatic, static head design, liquid level indicating systems in accordance with NAVSHIPS Dwg 810-1385847 may be found on older ships. Gages used in this configuration are calibrated with JP-5 having a specific gravity of 0.816. Typically, these types of TLIs are usually scheduled for replacement with one of the other forms of TLIs. Second, an electric TLI system (MIL-L-23886) utilizes a magnetic float (MF) sensing technique. The MF floats on the surface of the liquid level and travels on a transmitting rod with the rise or fall of the liquid. The level at which the MF is located is used to equate the capacity through a calibrated TLI meter. For JP-5 contamination tanks, the tanks are typically equipped with two indicating systems, one to show JP-5 and air interface and one to show JP-5 and water interface. The third type of TLI is the sounding tube pulse radar unit. A sounding tube pulse radar unit is installed at the top of a tank's sounding tube. The radar unit transmits signals down the sounding tube, where the signal reflects off of the top of the liquid level and returns to a receiver integral with the radar unit. The radar unit software uses the time required for the signal to travel to the level surface and return to calculate the level in the tank. The software then equates the sounding level to gallons and provides tank level data to output source, such as a meter, digital display or computer. Overflow tank indicators should be clearly marked to indicate the tanks from which they receive overflows. In the standpipe configuration, the overflow tanks have low level and high level alarms, at 5 and 95 percent, respectively. Additionally, to prevent overflow, the standpipe liquid level is monitored. A 50-gallon JP-5 drain tank is provided where a dedicated, contamination tank is not installed or oily water drain collecting system is not readily available.

542-4.4.2 AIR CAPABLE SHIP JP-5 RECEIVING SYSTEM. A pressure filling system is installed for filling the JP-5 storage tanks. The system is piped and sized to obtain the required receiving rate with a maximum pressure of 40 psig at the deck filling connection. The deck filling connection(s) is located to accommodate receipt of JP-5 in bulk from shore facilities and specified fueling-at-sea arrangements. Deck connections for 4-inch and

smaller fuel hose terminate in a gate valve installed in the vertical deck riser. A 90-degree elbow is installed at the deck connection with a pressure gage connection and a valved sampling test connection. The filling connection line connects to the transfer main serving the JP-5 storage tanks.

542-4.4.3 AIR CAPABLE SHIP JP-5 STRIPPING SYSTEM. The JP-5 storage, service, and drain tanks have a stripping tailpipe. Each tailpipe contains a stop-check valve and leads to a stripping main. The main contains stripping pump(s), sight glass, a test connection, and a cutout valve. The stripping discharge is directed to an oily waste holding tank or contaminated oil settling tank through a stop-check valve. In some instances, stripping discharge can be directed to a slack JP-5 storage tank due to the limited capacities of the oily waste holding tank or contaminated oil settling tank.

542-4.4.4 AIR CAPABLE SHIP JP-5 TRANSFER SYSTEM. The JP-5 transfer system typically consists of a 50-gpm transfer pump and a 75-gpm transfer filter separator. The system is arranged to permit transfer of JP-5 between storage tanks, and distribution of filtered JP-5 to the deck connections for small boat filling and to the JP-5 service tanks via the transfer filter separators.

542-4.4.5 AIR CAPABLE SHIP JP-5 SERVICE SYSTEM. Each JP-5 service tank for helicopter service typically can support maximum flight operations of the largest helicopter for 6 hours. On older ships, the system for servicing helicopters typically includes a 50-gpm service pump and a 50-gpm service filter separator. Newer ships have 100-gpm pumps and filter separator. The JP-5 service pump takes suction from the service tank and discharges through the service filter separator to the helicopter fueling stations. A service system, unloading valve (pressure regulating valve) is typically installed to insure fueling pressures do not exceed 55 psig. The service system arrangement allows the filter separator discharge piping, including fueling hose and nozzle, to drain back into the service tanks.

542-4.4.5.1 Helicopter In-flight Refueling System. Helicopter In-flight Refueling (HIFR) is used to refuel a helicopter from the ship, while the helicopter is in-flight, which increases helicopter capabilities. Most air capable ships are equipped with a NATO High Capacity (NHC) HIFR assembly (NSN 4720-01-293-0815). The NHC HIFR assembly consists of the following: (a) 100 feet length of on-deck refueling hose, (b) 100 feet length of refueling hose with a deck tie down fitting, (c) automatic emergency breakaway coupling, (d) 10 feet length of refueling hose, (e) closed circuit refueling (CCR) nozzle, and (f) associated unisex hose couplings. Ships with HIFR capability require service pumps producing adequate discharge pressures to deliver in-flight fueling to the helicopter at rated capacity of 50 (or 100) gpm.

542-4.4.5.2 Helicopter Fueling Station. To permit helicopter fueling in the landing area, or in-flight, provide the helicopter fueling station with the following items:

- a. A 2-inch fueling hose for ships having HIFR capability (100 feet collapsible and 100 feet non-collapsible). A 1-1/2-inch fueling hose for ships not having HIFR capability.
- b. One 1-1/2-inch, gravity-flow fueling nozzle.
- c. One 2-1/2-inch D-1R pressure fueling nozzle with hose end pressure control valve (HEPCV).
- d. One CCR nozzle with hose end 45 psig (+/- 5 psig) regulator. Approved CCR nozzles are Aeroquip model AE87548R and JC Carter model 64048B.
- e. Adapters for connecting each nozzle to the hose.
- f. A HIFR assembly with automatic breakaway.

- g. A sampling connection at the fueling station.
- h. A remote emergency switch for stopping the JP-5 service pump motor.
- i. Flushing connection(s) to permit flushing of the service system and fueling hose (with nozzle). Flushed fuel is directed back to the storage tanks.
- j. A hose reel for storing hose to preclude damage or water entry.

WARNING

Flash point shall be conducted on fuel extracted from aircraft low-point drains before defueling any aircraft. Aircraft with fuel having a flash point less than 140° F shall not be defueled into ship's JP-5 system, or drained into any other shipboard system, such as an oily waste system. Use of the aircraft-to-aircraft transfer cart is recommended, if installed, to handle low flash point fuel. Additional requirements for handling lower flash point fuels are covered in NAVAIR 00-80T-109, Aircraft Refueling NATOPS Manual . If required, defuel overboard where permitted by NSTM Chapter 593, Pollution Control.

542-4.4.5.3 Helicopter Defueling System. Ships having aircraft maintenance facilities have a 25-gpm portable air-driven defueling pump for defueling the helicopters in the helicopter service area. The defueling pump takes suction from the helicopter fueling connection. The defuel pump suction hose is 1-1/2 inches and has a 1-1/2- by 2-1/2-inch adapter for attaching to the 2-1/2-inch pressure fueling nozzle. The length of the suction hose required is 10 feet. Hose and adapters are provided to permit the defueling pump to discharge to the fueling hose flushing line (back to the JP-5 storage tank) or to a valved riser connecting the helicopter service area to the downstream side of the JP-5 stripping pump discharge stop-check valve or to the oily waste transfer system deck connection. A warning plate is provided at the hose flushing line stating: The connection is for defueling of helicopter JP-5 clean fuel only. A warning plate is provided at the riser to the JP-5 stripping discharge stating: **The connection is for defueling of contaminated helicopter JP-5 fuel only.**

542-4.5 AIR CAPABLE SHIP JP-5 SYSTEM OPERATIONS

542-4.5.1 OPERATIONAL PROCEDURES AND SAFETY INFORMATION. Operate the fuel systems under the direct supervision of the office in charge. Read all JP-5 safety precautions in [Section 2](#) before starting any fueling operations. Only thoroughly trained PQS-qualified personnel shall be involved in fuel system operations. Schedule fuel system operations to rotate tanks. See [Table 542-4-2](#) for a summary of basic JP-5 operations on air capable ships. Use the Operational Sequencing System where installed. Aviation fuel system operating procedures for air capable ships are typically found in either the Aviation Fuel System Operational Sequencing System (AFOSS) or the Engineering Operational Sequencing System (EOSS). Fuel system certification requirements are covered in detail in the Air Capable Ships Aviation Facilities Bulletin for specific ships.

Table 542-4-2. AIR CAPABLE SHIP BASIC JP-5 OPERATIONS

Operation	Drawn From	Deliver To	Pumps Used
Filling tanks	Deck fill connections	Storage tanks	None

Table 542-4-2. AIR CAPABLE SHIP BASIC JP-5 OPERATIONS -

Continued

Operation	Drawn From	Deliver To	Pumps Used
Transferring	Storage tanks	Service tanks	Transfer pumps via transfer filters
Fueling helicopters	Service tanks	Helicopters	Service pumps via service filters
Defueling helicopters	Helicopters	Storage tanks/oily waste tank or contaminated settling tank	Defueling pump
Offloading	Storage or service tanks	Deck fill connections	Transfer or service pumps
Stripping	Storage or service tanks	Oily waste tank, contaminated settling tank, or slack storage tank	Stripping pumps

542-4.5.2 RECEIVING JP-5 ON AIR CAPABLE SHIPS. JP-5 storage tanks shall be stripped with the stripping pumps before receiving JP-5 onboard. Stripping discharge is directed to a contaminated settling tank, oily waste holding tank, or a slack JP-5 storage tank (if configuration permits). Before and during receipt of JP-5 (every 15 minutes), take samples at the deck fill connection into containers that permit visual inspection of the fuel. Acceptable JP-5 fuel shall be clear, bright, and without free water in accordance with the free water visual test in paragraph 542-5.3.3, test f. A cloud, haze, specks of particulate matter, or free water indicates that the fuel is unsuitable and points to a breakdown in fuel handling equipment or procedures. Refuse fleet oiler or barge deliveries if the JP-5 contains solids in excess of 10 milligrams per liter, or if it is not clear and bright with no visible water.

542-4.5.3 JP-5 STRIPPING ON AIR CAPABLE SHIPS. A stripping pump (either hand-operated or motor-driven) is provided for stripping the storage, service, and drain tanks. Each tank has a stripping line that leads to a stripping main for discharge of sludge and water by the pump. Check the storage and service tanks for contamination using the test connection at the stripping pump discharge, and strip if required. Storage and service tanks shall be stripped periodically as specified in paragraph 542-7.6.

NOTE

While sampling tanks on air capable ships with motor-driven stripping pumps, it is important that stripping time be minimized in order to conserve fuel. A representative sample should be achievable after 15 seconds dependent upon the distance of piping between tank and pump suction. Ensure a representative sample is achieved. The service tanks may be stripped back to a JP-5 storage tank, if the system configuration permits.

542-4.5.4 AIR CAPABLE SHIP JP-5 TRANSFER SYSTEM OPERATION. During the transfer of JP-5 from storage to service tanks, for ships without an in-line fuel quality sensor (Autogrape), take samples for visual examination from the transfer filter separator outlet at 15-minute intervals. Samples must be clear and bright. For ships equipped with an in-line fuel quality sensor, an alert/alarm on the control console will inform the operator of a sample exceeding fuel quality limitations. Particulate matter or free water indicates that the fuel is probably unsuitable and points to a breakdown in the transfer filter separator. If visual samples fail to meet this test, either manually or via the in-line fuel quality sensor, secure transfer operations until acceptable samples are obtained by performing the following procedure:

1. Re-strip the appropriate storage tanks to obtain clean samples at the stripping pump outlets, and clear and bright samples at the transfer filter separator discharge. If this step does not produce acceptable samples, proceed to step 2.
2. Replace transfer filter coalescer elements. Inspect separator elements, and replace as necessary. Ensure that all elements are installed correctly.

542-4.5.5 AIR CAPABLE SHIP JP-5 SERVICE SYSTEM OPERATION. When performing any JP-5 service system operation, observe precautions in [Section 2](#).

542-4.5.5.1 Service System Startup. Basic startup procedures for the service system are:

1. Strip service tanks before each use, using the stripping system.
2. Sample service tank fuel for analysis by ship's aviation fuel laboratory as required by [Table 542-7-1](#).
3. Line up the service pump to take suction from the designated service tank and to discharge through the service filter separator to the helicopter fueling station.
4. If installed, line up the pump's recirculating line to permit recirculation to the tank from which suction is being taken. This line is sized so that enough JP-5 is recirculated to prevent the pump from overheating during no-flow conditions.
5. Drain service filter low point drains. Visually inspect for water. Continue to drain until all water is removed. Vent and refill filter prior to refueling operations.
6. Start the service pump with the discharge with discharge valve cracked open. When the pump reaches rated discharge pressure, slowly open the discharge valve to build up pressure in the service system. Sudden high-velocity flow causes hydraulic hammer, which shocks the service filter separator, sometimes damaging the elements. Ensure that the filter bypass valve is closed.

542-4.5.5.2 Service System General Operating Information. The following instructions should be observed during service system operation:

1. During fueling operations without installation of an in-line fuel quality sensor (Autogrape), sample for visual examination and conduct shipboard tests for solids contamination and free water. Take samples from service filter separator discharge and from fueling station hose nozzles in accordance with [Table 542-7-1](#). Refer to [Table 542-7-1](#) for ships outfitted with in-line fuel quality sensors.

NOTE

Filters shall be monitored during all operations. Note filter differential pressure and sight glass gage for normal filter operation and presence of water.

2. Stripping of service tanks is imperative to ensure that water-contaminated fuel is not delivered to the aircraft. Stripping intervals are specified in paragraph [542-7.6](#).
3. After fueling, store hose on hose reel if practicable, or on a rack near the JP-5 delivery valve. Store hose to preclude damage or water entry.

542-4.5.5.3 Fueling and Defueling Preparations for Helicopters. All personnel involved must be thoroughly experienced in helicopter fueling and defueling operations and safety precautions as follows:

1. Before any fueling operation is begun, the engines of the aircraft are normally stopped and all electronic gear turned off, except as required by an aircraft Naval Air Training and Operating Procedures Standardization (NATOPS) manual.
2. Helicopters equipped for pressure fueling may be hot refueled during training, operational, and combat situations. The Landing Signalman Enlisted (LSE) is in charge and shall control the operation and personnel involved. Chock and tie down the aircraft in accordance with the aircraft NATOPS manual. Conduct fueling in accordance with Naval War Publication (NWP) 3-04.1, **Shipboard Helicopter Operating Procedures**.
3. Plane captains shall be at their helicopter, and helicopter engines are stopped. Secure all electronic and electrical switches not required for fueling.
4. The Damage Control Assistant (DCA) on air capable ships shall ensure that the helicopter fire party is properly organized and trained.
5. Fueling crew shall stand by with a PKP or CO₂ portable extinguisher. Make swabs and seawater available for cleaning up any fuel spills.
6. Align the JP-5 service system to take suction from a designated service tank and discharge to the stations via the service filter separator.

CAUTION

The fuel crew shall be constantly alert to maintain cleanliness of the fueling area as serious damage to an aircraft engine can result from ingesting foreign object damage (FOD).

542-4.5.5.4 On-Deck Helicopter Fueling. Unless acceptable sample results (manually or via in-line fuel quality sensor) have been secured within a 24-hour period, before fueling helicopters, flush fueling hose until a clear and bright sample (manually) or acceptable in-line fuel quality sensor reading is obtained. Refer to [Table 542-7-1](#) for sampling requirements. See [Figure 542-4-1](#) for configuration requirements to conduct the following procedures for helicopter on-deck fueling and flushing.

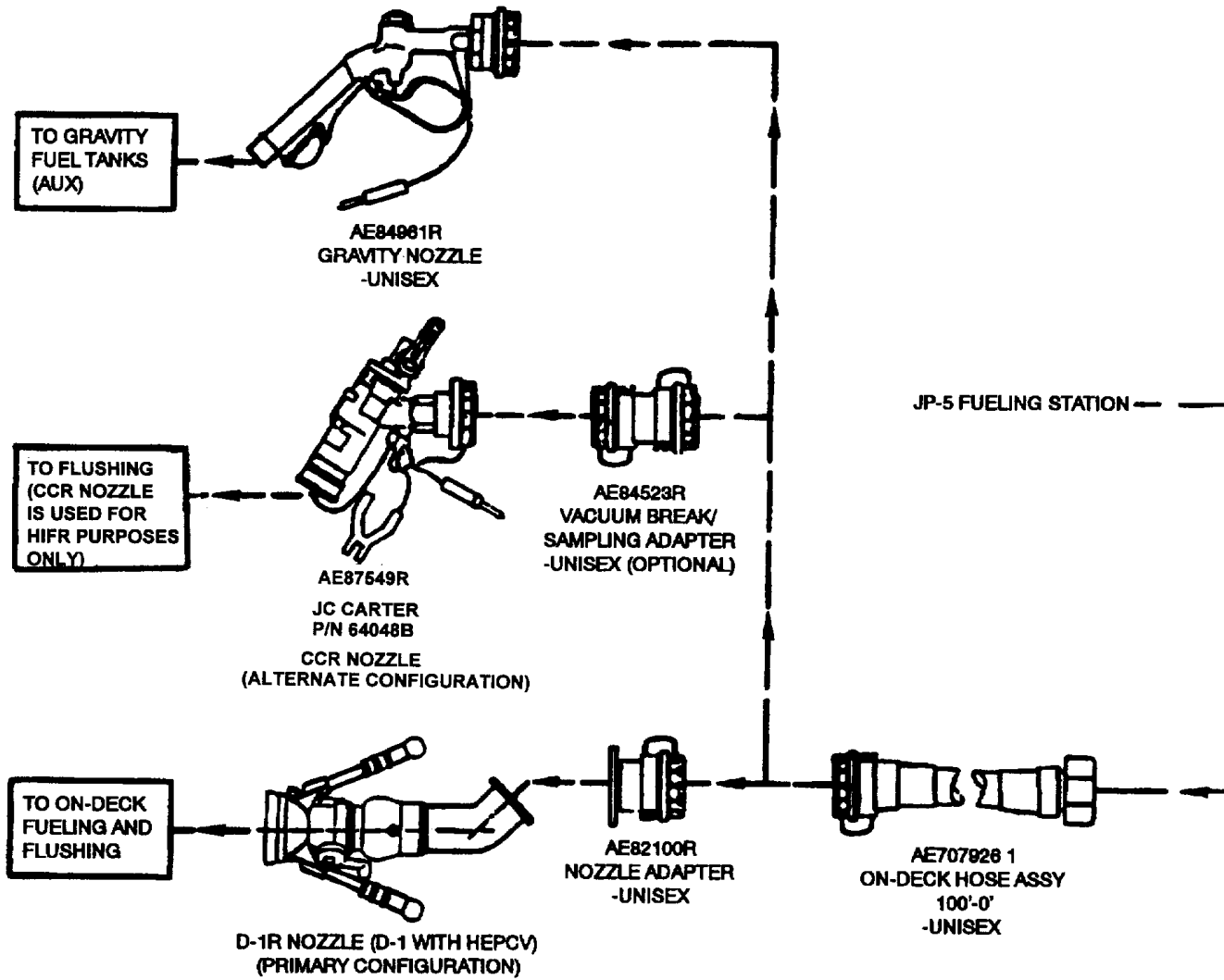

Figure 542-4-1. Helicopter On-Deck Fueling and Flushing

1. Unreel the hose and proceed to aircraft to be fueled.

NOTE

Ground connections shall be made to bare metal.

2. Connect ground wire to metal deck, then to aircraft.
3. Connect ground wire from gravity (over wing) nozzle to aircraft metal, as applicable.
4. Remove refueling adapter cap from the aircraft.
5. Remove dust cover from the pressure fueling nozzle.
6. Lift nozzle, using lifting handles, and align the slots on the nozzle with the lugs on the aircraft adapter.
7. Press nozzle firmly onto adapter; ensure that all three nozzle lock keys are depressed.
8. Rotate nozzle clockwise to a positive stop.
9. Open station riser valve.
10. Fuel aircraft as directed by plane captain. Nozzle operator to confirm actuation of aircraft automatic fuel shutoff valve (as applicable) and check for leaks. If valve malfunctions, or leaks are detected, shut the nozzle and secure refueling until repairs are accomplished.
11. Rotate the nozzle flow control handle to the FULL OPEN position. The handle must rotate 180 degrees to ensure that the poppet valve is fully open and locked.
12. When directed by plane captain, stop fueling aircraft. Shut the nozzle valve by rotating nozzle control handle 180 degrees to SHUT position.
13. Shut station riser valve.
14. Disconnect nozzle from aircraft.
15. Replace refueling adapter cap on aircraft.
16. Replace dust cover on the pressure fueling nozzle.
17. Remove nozzle ground wire from aircraft.
18. Remove ground wire from aircraft and then from metal deck.
19. Drain back hose and restow.

542-4.5.5.5 On-Deck Refueling of Helicopters with Engines Operating (Hot Refueling). Preparations for helicopter hot refueling are the same as for normal refueling except as noted below:

1. Pilot selects fuel loading, ensures that the cockpit switches are in the proper positions, and maintains UHF radio contact with the tower.
2. Pilot secures all electronic and electrical equipment not required for refueling.
3. Pilot places all armament switches to the SAFE position.

NOTE

Aircraft shall be chocked and have initial tiedown prior to attaching ground wire and fueling nozzle.

4. Attach ground wire to metal deck, then to aircraft. If using a gravity (over wing) nozzle, then attach ground wire from nozzle to aircraft. Remove refueling adapter cap from aircraft.
5. Nozzle operator attaches nozzle to the aircraft.
6. The plane captain then signals the nozzle operator to commence fueling. Nozzle operator to confirm actuation

of aircraft automatic fuel shutoff valve (as applicable) and check for leaks. If valve malfunctions, or leaks are detected, shut the nozzle and secure refueling until repairs are accomplished.

7. When the required fuel has been added, the nozzle operator shuts off the fuel, evacuates the hose, disconnects the nozzle, removes the nozzle ground wire from the aircraft (if using the gravity nozzle), replaces refueling adapter cap, and replaces dust cover on the pressure fueling nozzle.
8. Remove the ground wire from the aircraft.
9. After ensuring that all equipment is disconnected, the aircraft can be moved out of the area.

542-4.5.5.6 HIFR Preparations. Align the ship fueling system as required for on-deck fueling. Attach the HIFR assembly with CCR nozzle to the end of the deck hose. See [Figure 542-4-2](#) for configuration requirements to conduct HIFR. Proceed as follows:

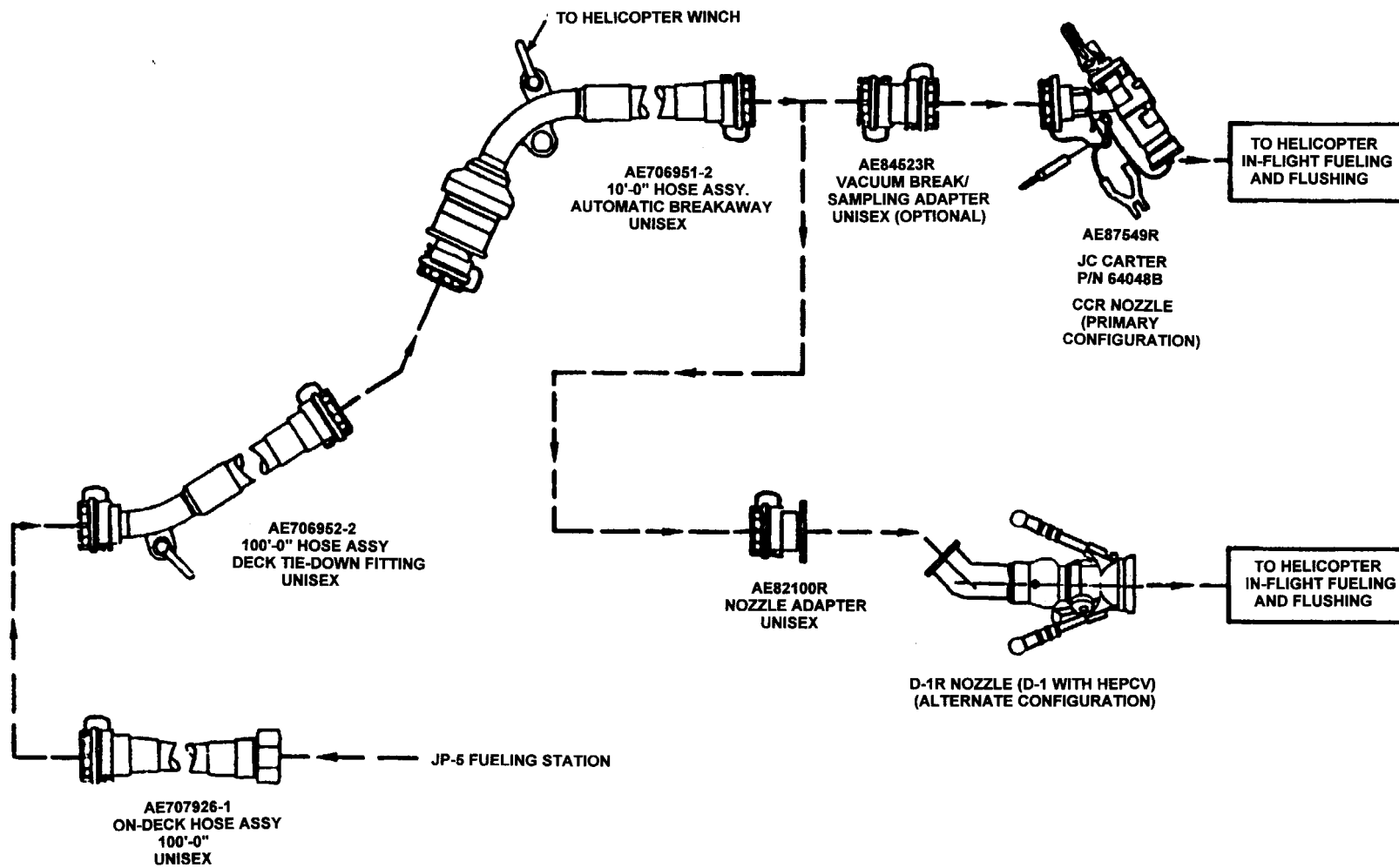

Figure 542-4-2. Helicopter Inflight Fueling and Flushing

NOTE

All NATO countries may conduct HIFR operations from U.S. ships equipped with the new Aeroquip HIFR assemblies using the standard D-1 pressure fueling nozzle. This provides those aircraft crews with the same automatic quick-disconnect capability now provided to U.S. flight crews.

1. Check the grounding circuits on jacks, clip, nozzle, and automatic breakaway unit for circuit continuity.
2. Flush the fueling system until an acceptable sample is obtained (manually or via in-line fuel quality sensor). Refer to [Table 542-7-1](#) for sampling requirements.
3. Check the pressurized hose for leaks.
4. Depressurize the hose, but do not drain the hose.
5. Lower all flight deck safety nets (if applicable) and other obstructions.
6. Inspect the entire area of the ship that is subject to helicopter rotor wash to prevent Foreign Object Damage (FOD).
7. The rescue boat shall be made ready and the boat crew shall be on station.
8. Secure all hatches and scuttles in the refueling area.

CAUTION

Advise aircraft personnel to monitor fuel quantity gages to ensure that fuel is being received.

542-4.5.5.7 HIFR Procedure. Refueling of helicopters while in flight is conducted according to the following operating procedure:

WARNING

Personnel shall not touch the hoist hook as it is lowered from the helicopter. Static discharge may be dangerous. Ground the pickup hook with the grounding wand to avoid electrical shock from the aircraft hoist cable.

1. The helicopter will make an approach, hovering so that a static bond can be established between aircraft and ship deck, and the hoist hook can be engaged with the loop attached to the fueling hose saddle. The fueling hose shall not be pressured.
2. If the pilot desires to see the fuel sample, he should request it prior to HIFR hookup and furnish a bag for pickup.

WARNING

All personnel shall remain clear of the area between the fuel hose and the port deck edge after the helicopter has received the fuel hose. If the hose should be drawn taut, personnel in this area could be pulled overboard.

3. When the fueling hose is hoisted, the helicopter crewman shall first attach the grounding wire to the airframe, then attach the fueling nozzle to the fueling adapter. The helicopter will then move clear of the deck to port, slightly lowering its altitude. The crewman will then signal to commence pumping fuel.

NOTE

The Aeroquip quick-disconnect fitting provides for automatic emergency break-away. If it becomes necessary to use this automatic breakaway feature, secure pumping of fuel immediately. Thoroughly flush the equipment before it is used again.

4. During pumping operations with the helicopter hovering clear of the ship, at least two crew members shall tend the fueling hose to prevent excess slack from developing in the hose. It is absolutely essential that no excess strain be placed upon the hose. Under strain, the automatic breakaway device will actuate, dropping the hose into the sea.
5. When fueling is complete, the crewman shall signal for the pumping to stop, and the hose shall be drained back. The helicopter will then be repositioned over the deck. Disconnect and lower the hose.

542-4.5.5.8 Helicopter Defueling. The following procedure provides for defueling aircraft on ships equipped with CLA-VAL type fueling stations. Ships not provided with CLA-VAL type stations are equipped with portable air-driven defuel pumps.

WARNING

Flash point shall be conducted on fuel extracted from aircraft low-point drains before defueling any aircraft. Aircraft with fuel having a flash point less than 140° F shall not be defueled into ship's JP-5 system, or drained into any other shipboard system, such as an oily waste system. Use of the aircraft-to-aircraft transfer cart is recommended, if installed, to handle low flash point fuel. Additional requirements for handling lower flash point fuels are covered in NAVAIR 00-80T-109, Aircraft Refueling NATOPS Manual . If required, defuel overboard where permitted by NSTM 593, Pollution Control .

1. Unreel the non-collapsible hose and proceed to aircraft to be defueled.

NOTE

Ground connections shall be made to bare metal.

2. Connect ground wire to metal deck, then to aircraft.
3. Remove refueling adapter cap from the aircraft.
4. Remove dust cover from the pressure fueling nozzle.
5. Lift nozzle, using lifting handles, and align the slots on the nozzle with the lugs on the aircraft adapter.
6. Press nozzle firmly onto adapter; ensure that all three nozzle lock keys are depressed.
7. Rotate nozzle clockwise to a positive stop.
8. Open station defuel valve.
9. Start defuel pump.
10. Defuel aircraft as directed.
11. Rotate the nozzle flow control handle to the FULL OPEN position. (The handle must rotate 180 degrees to ensure that the poppet valve is fully open and locked by toggle action.)
12. When defueling is complete, shut the nozzle valve by rotating nozzle control handle 180 degrees to SHUT position.
13. When the hose has completely emptied, as indicated by significant discharge pressure drop, stop defuel pump and shut defuel valve.
14. Disconnect nozzle from aircraft.
15. Replace refueling adapter cap on aircraft.
16. Replace dust cover on the pressure fueling nozzle.
17. Remove ground wire from aircraft, then from metal deck.
18. Rewind hose on reel.

542-4.6 JP-5 SYSTEM TROUBLESHOOTING (AVIATION SHIPS AND AIR CAPABLE SHIPS)

542-4.6.1 JP-5 PUMP FAILS TO TAKE SUCTION. If the JP-5 pump fails to take suction, refer to appropriate manufacturer's technical manual and **NSTM Chapter 503, Pumps**.

542-4.6.2 MALFUNCTIONS OF JP-5 TANK LEVEL INDICATORS. Consult the manufacturer's technical manual and **NSTM Chapter 504, Pressure, Temperature, and Other Mechanical and Electromechanical Measuring Instruments**, in specific cases of JP-5 tank level indicator malfunction.

542-4.6.3 WATER IN JP-5 SYSTEM. Water in the JP-5 system is more serious than water in a gasoline system because water and JP-5 are more difficult to separate, and because jet engines cannot tolerate it. Therefore, ensure stripping procedures are rigidly followed. If water continues to contaminate the system, check the JP-5 purifiers, filter separator, filter elements, and associated automatic drain/shutoff devices for proper operation. Refer to [Section 6](#).

542-4.6.4 MICROBIOLOGICAL GROWTH IN JP-5. Microbiological contamination is evidenced by a slimy-gelatinous substance in the fuel, usually at an interface between JP-5 and unremoved water. Proper stripping procedures and frequent turnover of the fuel load will eliminate or minimize this growth.

542-4.6.5 FAILURE OF JP-5 FUELING STATION SOLENOID VALVE. If a fueling station is not operating properly, but can be made to deliver manually, try the following procedure for isolating the electrical problem:

1. Disconnect the control wire at the hose reel connection (see [Figure 542-4-3](#)).

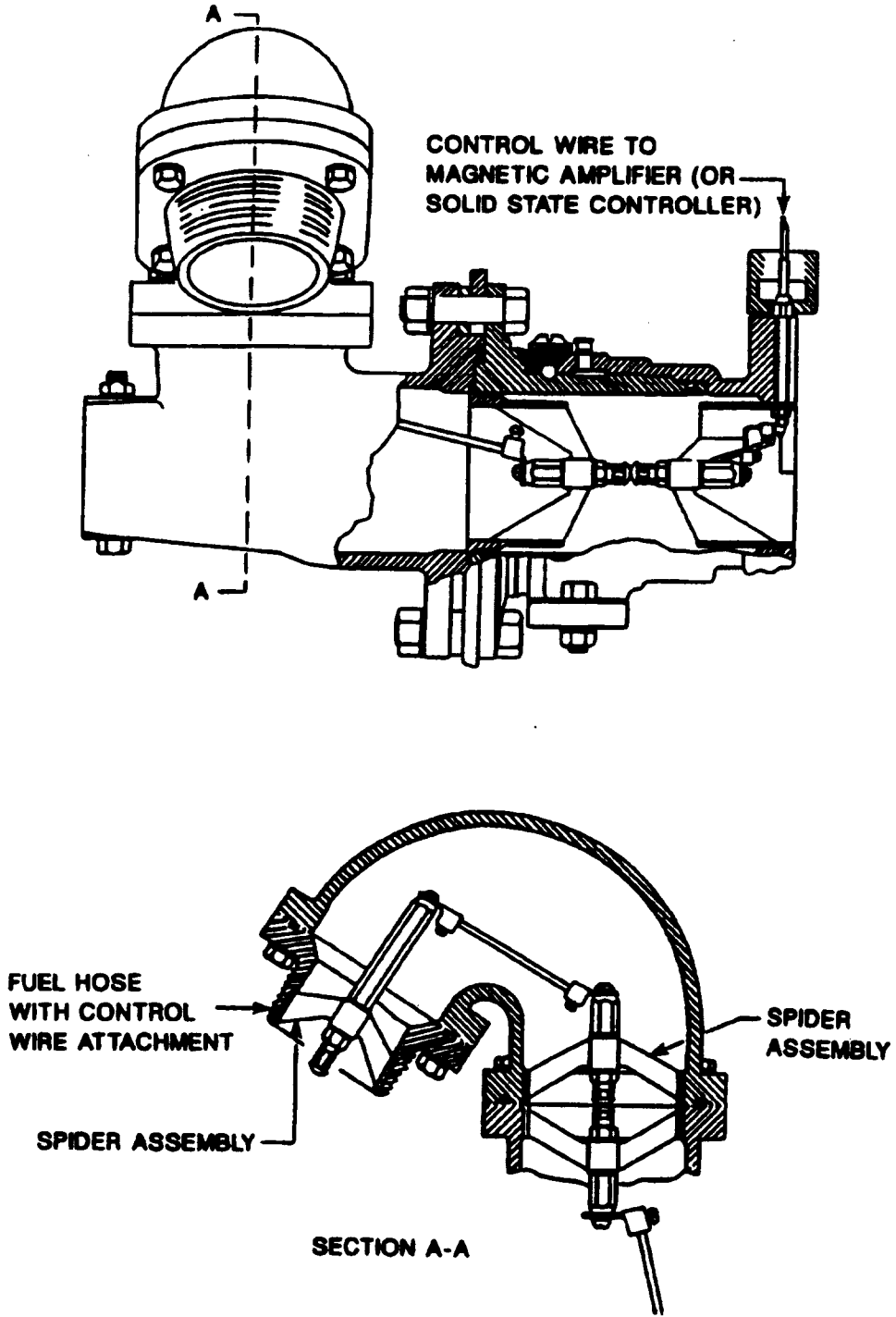

Figure 542-4-3. Hose Reel Fluid Path with Control Wire

2. To check for proper operation of the system, exclusive of the control wire in the reel and hose, start the station. If the solenoid is energized at this time, the control wire is shorted to ground between the hose reel connection of the wire and the connection at the magnetic amplifier (or solid state control). Disconnect the wire at the magnetic amplifier, then locate and eliminate the short to ground.
3. If the solenoid does not energize when the station is turned on, touch the control wire lead (just disconnected from the hose reel connection) to ground. If the valve solenoid operates and the hose is primed with fuel, remove the wire from ground. The solenoid should return to its original position and the hose should defuel and collapse. Proper operation of the solenoid during this procedure would eliminate the magnetic amplifier and solenoid from the possible suspects. Proceed to next step. (If the solenoid doesn't operate properly, the magnetic amplifier and solenoid would be likely suspects and should be tested according to applicable ship manual).
4. Next, using an ohmmeter, check for continuity of the control wire in the hose and reel, from the alligator clip and plug termination on the nozzle to the reel connection. If this reading is less than 140 ohms, it is satisfactory. If it is greater, check for dirty connections at the hose and reel contactor assemblies, weak springs on the contactor plunger, or broken wires in the reel or hose.

CAUTION

Ensure that control wire is disconnected at the hose reel connection. The system shall never be meggered back through the magnetic amplifier, since damage will occur from placing a 500-volt megger across parts rated at lower voltages.

5. If continuity check was satisfactory, examine the hose and reel for low impedance to ground. Roll out the hose on the deck and, with the control wire still disconnected, megger the hose and reel. If this reading is two million ohms or greater, it is satisfactory. If it is less than this value, remove the hose and megger the hose and reel separately to determine if either or both has a low impedance to ground. If this is determined, check for bare wires touching the metal hose or reel fittings, or for defective contactor assemblies or pin bushing.
6. If an aircraft must be fueled by manually operating the valve solenoid, it is still necessary to ground the aircraft to the deck.

NOTE

Refer to technical manual SG-120-AB-MMO-010, **Description and Maintenance of the Electrical Continuity Control System for Aircraft JP-5 Fueling Stations.**

542-4.6.6 HELICOPTER FUEL TANK OVERPRESSURIZATION. Ships that have helicopter fueling capability on deck and in flight shall ensure that the adjustable pressure-regulating valve is set for the correct fueling operation. Failure to adjust the pressure-regulating valve to the required pressure may result in aircraft fuel tank overpressurization. refer to SIB/PMS for pressure settings.

542-4.7 JP-5 SYSTEM MAINTENANCE (AVIATION SHIPS AND AIR CAPABLE SHIPS)

542-4.7.1 JP-5 FILTER SEPARATOR MAINTENANCE. Refer to paragraph [542-6.2.4](#) for JP-5 filter separator maintenance.

NOTE

Due to adverse effects to downstream aircraft engine components upon fuel delivery, zinc anodes shall not be used in JP-5 tanks.

542-4.7.2 JP-5 TANK INSPECTION AND CLEANING. When cleaning JP-5 tanks, observe precautions in paragraph 542-2.4.1 and 542-2.4.2. Inspect and clean the storage and service tanks in accordance with the Planned Maintenance System (PMS). In the event that ships or Type Commander's policies prohibit tank entry for routine PMS, stringent management by Port Engineers, ships or Type Commanders should be followed. Port Engineers, ships or Type Commanders are to insure tanks are cleaned in accordance with the appropriate Class Maintenance Plan (CMP), Incremental Class Maintenance Plan (ICMP) or the applicable Tank and Void Program.

542-4.7.3 JP-5 TESTS AND SAMPLING INSTRUCTIONS. Refer to Section 7, Fuel Quality Management.

542-4.8 JP-5 SYSTEM PRESSURE TESTING (AVIATION AND AIR CAPABLE SHIPS)

542-4.8.1 GENERAL. The following quality assurance (QA) tests are ordinarily performed by contractor or shipyard, following repairs that require welded joints. Ship's force is required to witness all QA functions.

542-4.8.2 SYSTEM FLUSH. **NSTM Chapter 505, Piping Systems** identifies locations where silver brazed joints are prohibited. In instances where the use of silver-brazed joints are approved in the JP-5 system by the Technical Warrant Holder, after installation, flush silver-brazed joint in new, repaired or renewed piping for flux removal in accordance with **NSTM Chapter 505, Piping Systems**. With approval from the Technical Warrant Holder on the use of silver-brazed joints for new construction ships, air and SF6 refrigerant shall be used to test approved silver brazed joints.

542-4.8.2.1 Air Testing. For ships completing extended overhauls where the JP-5 system was dormant for 18 months or longer, consideration should be given to conduct system piping air testing in order to identify system piping integrity. Air testing may identify some leaks, but may not identify all leaks. Pressures shall not exceed system design pressures.

NOTE

Hydrostatic testing of JP-5 system piping introduces water into a fuel system. All water will not be removed upon the completion of the testing, regardless of the method used to remove the water. Only extensive system flushing will totally eliminate the water over an extended period of time. Strict adherence to operational procedures, including JP-5 quality assurance (QA) sampling, is required to insure elimination of water contamination.

542-4.8.3 HYDROSTATIC TEST OF PIPING. Test fluid shall be clean, fresh water. During the hydrostatic test, isolate the filters and all JP-5 pumps, including the aircraft fueling station defueling pumps.

542-4.8.3.1 Determine test pressure for the JP-5 fill and transfer system in accordance with one of the following:

- a. For ships with fill systems having a design pressure of 200 psig, hydrostatically test fill system at 135 percent of design pressure (270 psig).
- b. For aircraft carriers and oilers, with fill systems having a design pressure less than 200 psig, conduct hydrostatic testing of the fill system to 175 psig.

c. For ships other than carriers and oilers, with fill systems having a design pressure less than 200 psig, conduct hydrostatic testing of fill system to 150 psig.

542-4.8.3.2 The test pressure shall be held long enough (30 minutes minimum) to permit a thorough inspection of all valves, fittings, piping, and joints for leakage or weeping. Upon completion of the hydrostatic test, drain the system thoroughly and blow out with air.

542-4.8.3.3 refer to **NSTM Chapter 505** for tightness test at nominal operating pressure option in lieu of hydrostatic test.

542-4.8.4 OPERATIONAL TEST. After completion of the above tests, give the JP-5 system an operational test with JP-5.

NOTE

Perform operational test prior to departure from the availability, but before the first at-sea period.

542-4.8.5 ADDITIONAL TESTING INFORMATION. refer to **NSTM Chapter 505** for inspection requirements, test precautions, test intervals, testing of removed and refurbished piping system components, and requirements for remade mechanical joints or modified piping where hydrostatic testing is impractical.

SECTION 5 FLEET OILERS

542-5.1 INTRODUCTION

542-5.1.1 The fleet oiler functions as a transporter and supplier of fuel. The high costs of petroleum products and pollution-related environmental considerations necessitate clear priorities for carrying bulk fuel products. Policy guidance is provided in CINCLANTFLTINST/CINCPACFLTINST 4026.1, **Fuel Management Afloat Manual**. Precautions for fleet oilers are listed in paragraph 542-2.9. The cargo JP-5 system is arranged to receive JP-5 in bulk from shore or from ships alongside and to discharge it through a fueling hose to other ships alongside. There are no cargo MOGAS systems on fleet oilers. User ships receive gasoline by pierside delivery from gasoline trucks.

542-5.2 CARGO JP-5 SYSTEM

542-5.2.1 RECEIVING JP-5 ON OILERS. When cargo JP-5 is received or delivered, quality of product is defined by use limit specifications contained in the Fuel Management Afloat Manual, not by procurement specifications.

542-5.2.1.1 When cargo JP-5 is loaded, fleet oilers not provided with contaminated cargo JP-5 collecting tanks shall maintain an empty tank into which JP-5 tanks can be stripped before each Fueling-at-Sea (FAS) or Underway Replenishment (UNREP). Where piping arrangements permit, and maximum JP-5 load is needed, cargo JP-5 tanks may be stripped into the same tank used for receipt of cargo oil tank stripping.

542-5.2.1.2 Before receiving in port, port regulations shall be reviewed and preparations made to conform with all local requirements. Delays in cargo handling can be avoided by having all equipment ready at the time the ship arrives at berth. In most instances the following preparations can be arranged:

- a. All rigging gear at the manifold ready for arrival of hoses
- b. Valves set in advance, where possible
- c. Gear for rigging gangway ready
- d. Scuppers plugged
- e. Ullage covers and hatch covers undogged, but left in place
- f. Ullage screens in place under the covers
- g. Containers ready for use in taking samples
- h. Empty tanks stripped dry before arrival at the loading berth
- i. Ship gear ready for specific mooring requirements at the loading berth
- j. Ship tanks gaged; a copy of recorded results prepared for depot representative
- k. Before loading commences, take samples from the shore tanks (this may be accomplished by Defense Fuel Supply Center Quality Assurance Representative). Also, take samples from the bleeder valves along the line and at the dock header for check-testing to ensure cargo conforms to specification. Gage the shore tanks ullage; perform a watercut, and record temperature.

1. The Liquid Cargo Officer shall establish the tank sequence for filling while lining up the cargo system for loading. The tank loading sequence is very important because a ship is flexible. Uneven loading will cause hogging or sagging, and even leaks in the hull. Misalignment could also lead to contamination of liquid cargo.

542-5.2.2 TRANSFERRING AND OFF-LOADING CARGO JP-5. Any cargo movement within the ship (either in stripping to another tank or in transferring to another ship) will affect the stability, draft, and stress condition of the oiler. Obtain permission through the ship chain of command to begin any transfer operation. Officers whose primary duties dictate a positive need to know and who must approve cargo operations include:

- a. The Commanding Officer
- b. The Chief Engineer (Engineer Officer)
- c. The Damage Control Assistant
- d. The Supply Officer
- e. The Officer-of-the-Deck
- f. The Oil King

542-5.2.2.1 Record all cargo operations in cargo records and also in ship deck log. Times and actual conditions must be noted. Log any movement of cargo including discharge into the sea because cargo movement affects ship stability.

542-5.2.2.2 Before off-loading to refuel another ship, test an all-levels sample from each supplying tank to determine JP-5 appearance, color, specific gravity, solid contaminants, free water, and flash point. Enter test results in the replenishment record.

542-5.2.2.3 Before starting to pump cargo JP-5, and again 1 minute after starting to pump, a line sample shall be taken at the replenishment station manifold, and tested immediately for solid contaminants and free water. Use the contaminated fuel detector and the free water visual test (refer to paragraph 542-5.3.3, test f). Test results shall be made part of the replenishment record. Fleet oiler deliveries shall not contain more than 10 mg/L of solids, and shall be clear and bright with no visible free water. Samples shall be taken in clean, transparent bottles of 1 quart size minimum. (refer to Section 7 for exact container and test requirements.)

542-5.2.3 CARGO JP-5 STRIPPING PROCEDURES. Water-cuts using water-indicating paste shall be taken at least once every 3 days on all tanks, and every 24 hours after a fuel lift, until water has settled and been stripped out. Remember that water settles very slowly in JP-5 and rigid stripping procedures must be followed.

542-5.2.3.1 At each stripping, only free water shall be removed; additional settling time will drop the water to the bottom where it can be stripped, leaving the good fuel. When water-cuts indicate free water on the bottom above the low suction level in a storage tank, the tanks shall be stripped to the contaminated cargo JP-5 collecting tank, or the cargo JP-5 or settling tank. After appropriate settling time (to be determined by sample results) the contaminated tank(s) shall be drained until the sight glass reveals all water drained off and JP-5 appears in the sight glass. The contents of the contaminated tank(s) will then be returned to a storage tank(s) for issue.

542-5.2.3.2 Cargo JP-5 tanks shall be stripped at the times indicated below:

- a. Before receipt of cargo JP-5. Ships planning to be replenished in port shall strip tanks before entering harbor.
- b. The day after receipt of cargo JP-5. Ships that have replenished in port shall not strip tanks until after departure.
- c. On the day before transfer of cargo JP-5.
- d. Immediately before transfer of cargo JP-5.
- e. Weekly at sea, unless tanks have been stripped during the week as directed by steps a through d.
- f. When heavy weather is forecast, at sea. This will prevent free water, which has settled to the bottom of the tanks, from mixing with the JP-5 when riding out heavy seas.

542-5.2.4 BALLASTING OPERATION. Refer to ship liquid loading instructions for information concerning ballasting with seawater.

542-5.2.5 SHORE TANK VS. SHIP TANK GAGING DISCREPANCIES. Shore tank figures are the authority on official quantities delivered. However, if a discrepancy exists between the shore tank figures and ship tank calculations, make a recheck of the gages and calculations of all tanks. If there is still a discrepancy, take the following steps:

1. If the discrepancy is in favor of ship tanks, investigate to determine possible entry of material from other shore tanks.
2. If the discrepancy is in favor of the shore tanks, investigate for leaks and losses through the pipelines and pump houses. Ullage all tanks on the receiving ship to determine whether the excess fuel pumped by the shore activity may have entered other tanks. Where differences are unreconcilable, the shore tank figures are official. Any discrepancy between the amount invoiced and the quantity determined by the ship ullage tables will be adjusted as a gain or loss by inventory to the Navy Stock Account, and shall be covered by a DD Form 1149.

542-5.2.6 PIPING SYSTEMS. Inspect joints and valves in piping systems at frequent intervals and keep free from leaks. Consideration should be given to conducting a system piping air test where the cargo JP-5 system has been dormant for 18 months or longer. Air testing may identify some leaks, but may not identify all leaks. Pressures shall not exceed system design pressures. During system inspection, check the underside of topside piping.

542-5.3 CARGO JP-5 FUEL QUALITY

542-5.3.1 CONTAMINATION. Petroleum products become contaminated if commingled. Contamination of a fuel is defined as the presence of foreign matter or other petroleum products, resulting in failure of the fuel to meet specifications or use limit tests (refer to MIL-HDBK-200, **Quality Surveillance Handbook for Fuels, Lubricants, and Related Products**).

542-5.3.1.1 Investigation of Suspected Contamination. Whenever a product fails to meet testing requirements, immediately investigate sampling procedures, cleanliness of sample containers and storage conditions, testing procedures, and cleanliness of all operations and equipment. After investigation and correction of any discrepancies, if the product still fails, proceed as in paragraph [542-5.3.1.2](#).

542-5.3.1.1.1 Areas of possible contamination to consider are:

- a. Dissolved water. JP-5 changes in appearance with variations in ambient temperature because of the water solubility characteristics of the fuel. Cloud points have been observed with as little as 205° F (11.2° C) of change. Test by heating fuel samples to issue temperature, then using the free water visual test (refer to paragraph 542-5.3.3, test f).
- b. Leaks between tanks of different products, or from the sea through the hull.
- c. Rust and sediment resulting from improper tank cleaning procedures and schedules.
- d. Free water present in JP-5 (after stripping and water-cuts indicate no free water on the bottom) may result from:
 - 1 Pump strainer not drained of retained water.
 - 2 Open valves.
 - 3 Insufficient flushing of, or condensation in, hose.
 - 4 Leaking valves in eductor system or between sea chest and pump.

542-5.3.1.1.2 Sediment content in JP-5 line samples may fluctuate because of rust scale flaking off interior walls of ferrous piping. For this reason, a single line sample failing to meet the standards shall not be cause for rejection. Take at least three line samples (at commencement of pumping, 5 minutes, and 10 minutes after commencement of pumping) and analyze using the contaminated fuel detector. Average the results. If they are above standards, cease the transfer operation until sediment content is reduced. If operations necessitate, the receiving command may authorize the transfer operation to continue, but first take and test for sediment an all-levels sample or a composite of upper, middle, and lower samples from the receiving tanks. If this sample fails to meet standards, institute stripping procedures outlined in paragraph 542-5.2.3.

542-5.3.1.1.3 Microbiological growth in JP-5 is indicated by a slimy, gelatinous substance in the product, usually at an interface between JP-5 and unremoved water. Proper stripping procedures and frequent turnover of the cargo load can eliminate or minimize problems with this type of contamination.

542-5.3.1.2 Procedure for Reporting Contamination. When bulk cargo might be contaminated, or might not meet minimum specifications, perform the following procedures:

1. Draw several tank samples at different levels for submission to the nearest petroleum testing laboratory for analysis. Refer to MIL-HDBK-844(AS) for details regarding packaging, labeling, addressing, and shipping.
2. Isolate the product until after testing by the testing laboratory. When possible, discharge the product to isolated storage ashore while awaiting authorization for use or disposition.
3. Send a classified message report, furnishing all details available, following any incident involving refusal of Mobile Logistic Surface Force (MLSF) cargo by customer ships or shore stations.

542-5.3.2 TANK CLEANING. Periodic tank cleaning promotes safe fuel handling by identifying and/or removing sediment accumulation or microbiological growth. Planned Maintenance System (PMS) procedures are established to provide guidance on the frequency and procedures for tank cleaning. Deposits within the tanks are easily washed away by a fire hose with seawater. Wash water may be removed from the tanks by the main drainage eductors or by motor-driven stripping pumps, depending upon configuration. Portable drainage pumps can be used to complete removal of water. The danger of damaging the tank coating prohibits steaming out. In the event that ships or Type Commander's policies prohibit tank entry for routine maintenance, stringent management by Port Engineers, ships or Type Commanders should be followed. Port Engineers, ships or Type Commanders are to insure tanks are cleaned in accordance with the appropriate Class Maintenance Plan (CMP), Incremental Class

Maintenance Plan (ICMP) or the applicable Tank and Void Program. For additional information, refer to MIL-HDBK-291 (SH) **Cargo Tank Cleaning**. Discharge oily wastes generated by tank cleaning operations to a contaminated cargo JP-5 collecting tank, or cargo JP-5 or settling tank. refer to **NSTM Chapter 593, Pollution Control**, for additional information concerning disposal of oily wastes.

542-5.3.3 FUEL QUALITY TESTS. Tests that are beyond the oiler capability, or those required for verification purposes are usually made in laboratories ashore or at refineries and points of fleet issue. Fleet oiler personnel shall be familiar with the significance of test results. Because of the small volume of a product tested, any traces of dirt or residue from a previous sample or test that remain in the collection or test container will significantly change the test results. Therefore, it is essential that all bottles or other vessels used for collection of samples, including lids, caps, corks, and all test equipment, be scrupulously clean. Refer to **NSTM Chapter 541, Ship Fuel and Fuel Systems**, for applicable test methods. Oiler personnel are responsible for tests listed below, except flash point, which is the responsibility of the receiver (if equipped):

- a. Specific gravity. The purpose of the specific gravity test is to determine the weight per unit volume of a petroleum product. Specific gravity is expressed in degrees as standardized by the American Petroleum Institute (API). Specific gravity is used to determine the unit weight and total weight of a cargo of petroleum products and the draft of the ship after it is loaded. Specific gravity deviations will indicate any stratification or variation of a product in a tank. Specific gravity is a necessary factor for correcting volume to 60° F (15.6° C). It is also an indication of possible contamination with heavier or lighter product. Fleet oilers shall perform this test on all bulk petroleum oil and lubricants (POL) carried. The receiving ship uses specific gravity as one check to determine the product being supplied.
- b. Bottom Sediment and Water (BS&W). The BS&W test determines the amount of water and sediment by volume in a liquid fuel. The test provides an indication of contamination in the tank, by foreign substances contained in the fuel, which may result in clogged fuel lines, burner tips, fuel pumps, and injectors. Fleet oilers are equipped to perform the BS&W test by the centrifuge method.
- c. Flash Point. Flash point is the lowest temperature at which application of a test flame causes the vapors above the surface of the liquid to ignite. It is a means of estimating fire and explosion hazards. A flash point substantially lower than expected is a reliable indication of contamination by a highly volatile product such as gasoline.
- d. Color. The color of jet fuel is subject to change with age, but this is not detrimental to quality. However, other color changes may indicate pollution. When the fuel color at the time of the test is darker than the color reported at the time of receipt, a laboratory shall determine if the fuel is contaminated.
- e. Solid Contaminants. Perform the solid contaminant test with the contaminated fuel detector (CFD) or combined contaminated fuel detector (CCFD) (NSN 6640-01-013-5279). When testing aviation fuel for use in aircraft, solid contamination shall not exceed 2.0 milligrams per liter.
- f. Water Content of JP-5. The free water standard for cargo JP-5 carried in fleet oilers, to be transferred to ships, is clear and bright - no visible water. This is determined by the free water visual test, which is the only authorized acceptance test for this situation. The much stricter free water standard for JP-5 being fueled directly into aircraft after filtering shall not exceed 10 parts per million, not visible to the naked eye, which is checked by the free water detector test. The free water visual test for cargo JP-5 on fleet oilers is accomplished by drawing a line sample using a clean bottle or equivalent clear container. Swirl the sample so that a vortex is formed. If the fuel is cloudy, allow the sample to stand for several minutes and then determine suitability under the following criteria:
 - 1 If the bottom clears first, the cloudiness is caused by entrained air and no corrective action is required.

- 2 If the top clears first, the cloudiness is caused by entrained water. In this event fleet oilers will begin proper stripping of cargo tanks. Careful stripping will usually correct cloudiness caused by large amounts of free water.
- 3 If a replenishment sample remains cloudy, increase the temperature of the fuel sample by heating the sample-filled container in hot water to a temperature 25° F (14° C) higher than the temperature in the fleet oiler cargo tank. If the sample begins to clear, the cause of the cloudiness is dissolved water released from solution by a decrease in fuel temperature, and no corrective action is required.

NOTE

The heating of cloudy fuel samples to help determine if cloudiness is due to the precipitation of dissolved water applies to underway and/or in-port replenishment, not to aircraft refueling. It is not to be utilized as a standard procedure where visual sampling is employed when dispensing JP-5 to aircraft, small boats, or support equipment.

SECTION 6

MOGAS AND JP-5 SYSTEM COMPONENTS

542-6.1 PUMPS

542-6.1.1 MOGAS SYSTEM PUMPS. The following pumps are associated with the MOGAS systems:

- a. Seawater Compensating Pumps. These pumps are centrifugal, motor-driven, and have capacities that range from 100 to 220 gpm. They are used to pump seawater into the tanks to displace gasoline.
- b. Stripping Pump: These pumps are either hand-operated or motor-driven (rotary type) and are used to strip water and sediment from the bottom of the gasoline tank or draw off tank. Their capacities range from 10-35 gpm.
- c. Gasoline Pumps. One of three different pumps is provided to supply gasoline to the MOGAS fueling station(s):
 - 1 Seawater turbine-driven centrifugal pump.
 - 2 Electric motor-driven pump (centrifugal type) with a capacity of 35 to 160 gpm.
 - 3 Hand-operated pump with a capacity ranging to 30 gpm.
- d. Defueling Pumps. These pumps are located at the vehicle fueling stations on some LPD ships, and are used only for hose evacuation. Do not use for defueling vehicles. The pumps are electric motor-driven (rotary type) and have a capacity of 50 gpm.
- e. Seawater Leak-Off Pump. This is an electric motor-driven pump (centrifugal type) of 10 gpm capacity. It is used to maintain a pressed-up gasoline tank at all times.

542-6.1.2 JP-5 SYSTEM PUMPS. The following pumps are associated with the JP-5 system:

- a. Transfer Pumps. The JP-5 transfer pumps are electric motor-driven (rotary type), and are used to transfer JP-5 from storage to service tanks, to other storage tanks, and off the ship. Typically, a designated transfer pump is used to deliver fuel from the JP-5 contamination tank to the reclamation system on ships with a reclamation system. On aircraft carriers, LHA and LHD type ships the transfer pump(s) capacity is typically 200 to 300 gpm. On LPD and air capable ships, the transfer pump(s) capacity is typically 50 to 200 gpm.
- b. Service Pumps. Service pumps are electric motor-driven pumps that supply JP-5 from the service tanks to the aircraft fueling stations through the filter separator. The service pumps can also be used to deliver fuel to other ships in company or to off-load storage tanks. Aviation ships utilize centrifugal pumps with a range in capacity of about 200 to 1100 gpm. Air capable ships utilize rotary pumps with a range in capacity of about 50 to 150 gpm.
- c. Stripping Pumps. These pumps are either hand-operated or motor-driven (rotary type) and are used to strip water from storage and service tanks. Their capacity ranges from 30 to 50 gpm.
- d. Defueling Pumps. Defueling pumps are rotary type and either electric motor-driven or portable air-driven. Capacity ranges from 25 to 100 gpm.

542-6.1.3 PUMP OPERATION. Study the manufacturer's instruction book carefully before attempting to operate any fuel pump.

542-6.1.4 PUMP SAFETY. Pump safety precautions are as follows:

1. Since defueling pumps will overheat in the absence of liquid, secure pumps as soon as defueling is complete.
2. Check gages while the pumps are running to see that proper pressures are being developed.
3. Check bearing temperatures to ensure proper operation.
4. Check all pumps for binding, vibration, leaks, bearing noise, and proper oil level. Deal with any unusual operating condition immediately.

542-6.1.5 PUMP MAINTENANCE. Keep pump units clean. When not in service, pumps corrode. Refer to **NSTM Chapter 503, Pumps**, and to the appropriate pump technical manual for the complete description of pump maintenance.

542-6.1.6 PUMP TROUBLESHOOTING. Refer to **NSTM Chapter 503, Pumps**, and the appropriate pump technical manual for troubleshooting information.

542-6.2 FILTER SEPARATOR FOR MOGAS AND JP-5 SYSTEMS

542-6.2.1 FUNCTIONAL DESCRIPTION. The filter separator is designed to remove solids and water from gasoline or JP-5. The filter separator is a two-stage unit. The first stage consists of coalescing elements used for filtering solids from the fuel and for coalescing water into large droplets. The second stage consists of separator elements used to separate the coalesced water from the fuel (see [Figure 542-6-1](#)).

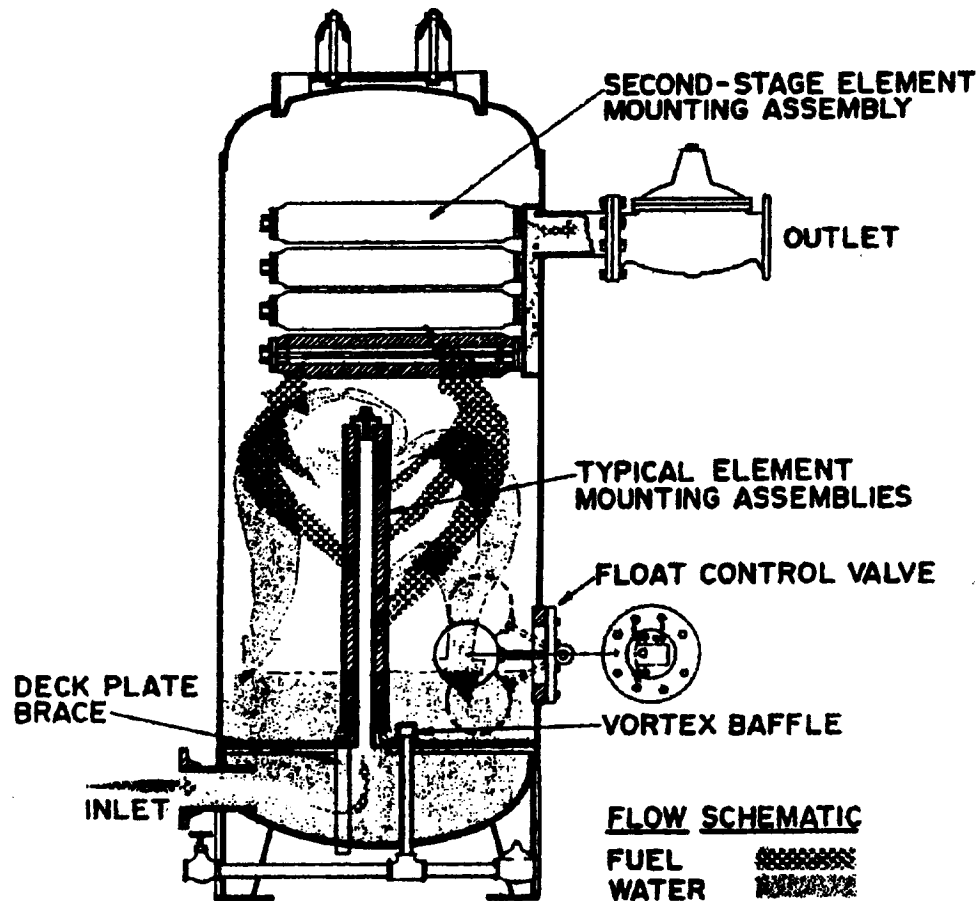

Figure 542-6-1. Filter Separator (Flow Schematic)

542-6.2.1.1 Contaminated fuel under pressure enters the unit through an inlet pipe and flows into and through the coalescing elements, which filter out the solid contaminants and coalesce the water into large droplets. The water settles out to the bottom of the unit, and the fuel flows through the separator elements, which remove any remaining water. Clean fuel is then discharged from the unit through the outlet. Filter flow rates vary from 50 gpm on air capable type ships to as high as 2,000 gpm on aircraft carriers.

542-6.2.1.2 Units can be Class 1 or Class 2. Class 1 units have automatic water drain and fuel discharge shutoff. Manual controls are also provided. Class 2 units only have manual controls for water drain and discharge shutoff.

542-6.2.2 FILTER SEPARATOR CONSTRUCTION. A typical unit (see [Figure 542-6-2](#)) has a cylindrical, welded, copper-nickel shell with legs welded to the shell for mounting. On new construction ships, the filter separator vessel may be constructed of stainless steel. A sight gage assembly, a differential pressure gage, an outlet pressure gage, an inlet pressure gage, and an outlet, sampling valve are attached to the unit. Access to the interior of the unit is through a bolted cover on the top or side of the unit. Coalescer and separator elements are removed and replaced through this access. The interior of the shell is divided into three chambers: the inlet, fallout and outlet. The inlet chamber is connected to the fallout chamber through the coalescer element; the fallout chamber connects to the outlet chamber through the separator elements. A water drain line from the fallout chamber passes through the inlet chamber to connect with the water drain system.

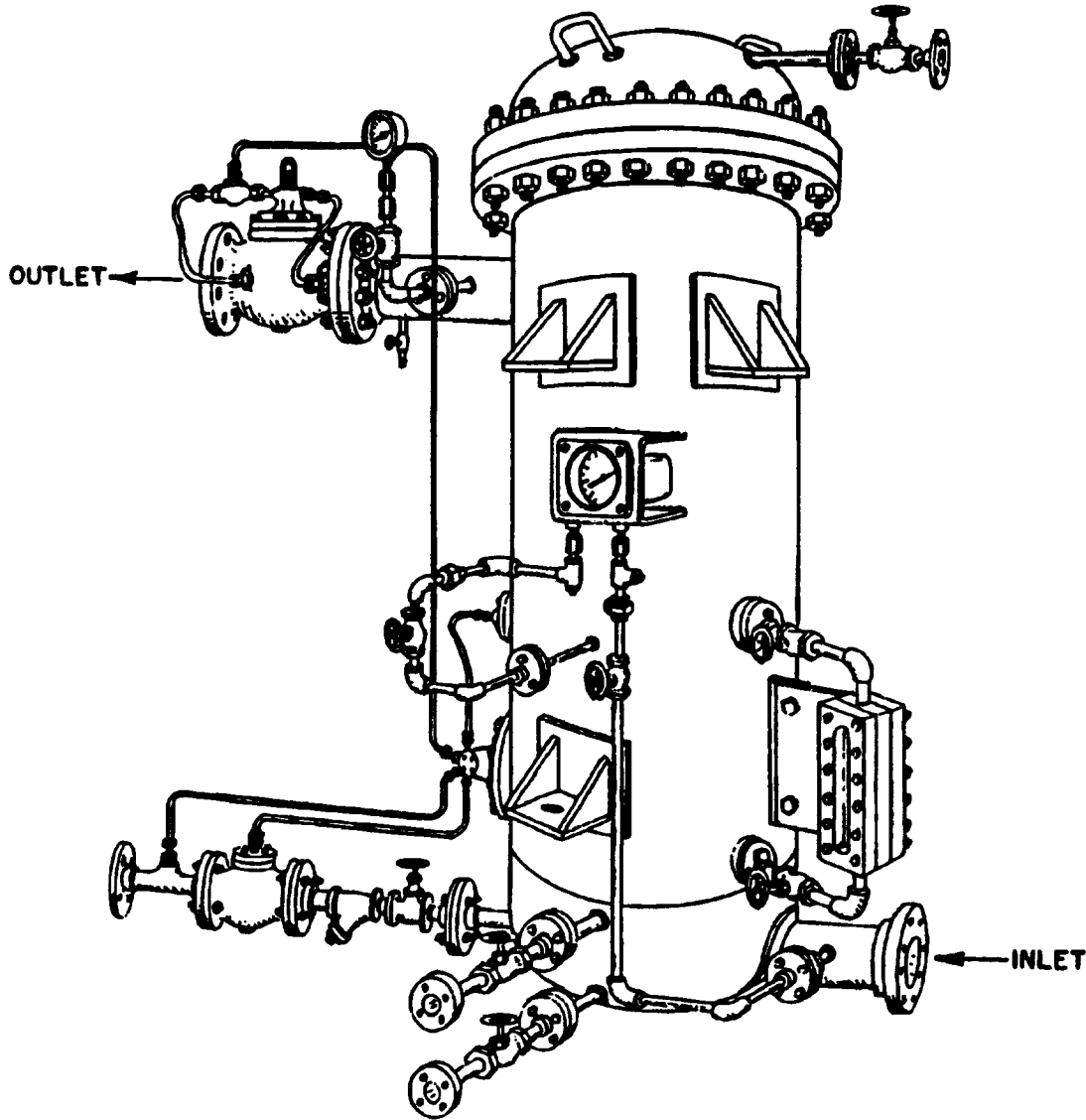

Figure 542-6-2. Filter Separator

542-6.2.2.1 For Class 1 units, a float control valve is bolted to a flange welded to the shell on or near the bottom. This valve is actuated by a captive float that rises and falls with the water level within the unit shell. The float control valve is connected by pressure control piping to the automatic water drain valve and the automatic shutoff valve located in the filter discharge line. A manually operated water drain valve is also provided in connection with the water drainpipe.

542-6.2.2.2 Some units have been upgraded with a float control tester. The tester permits manually checking the float and control functions while the filter separator is in service. In the normal operating position, a ballast is fixed to the float ball. The additional ballast weight permits the float ball to float in the water but not in the fuel. In the test position, the ballast is removed from the float, allowing the float ball to rise and float in the fuel. Observing the sequential operation of the water drain valve and the automatic shutoff (discharge) valve verifies the proper operation of the float and control functions. When the float is down, the drain valve is closed and the discharge valve is open. When the float is horizontal, the drain valve opens and the discharge valve remains open. When the float is up, the drain valve remains open, and the discharge valve closes.

542-6.2.2.3 The unit has a valved test connection at the outlet for sampling the discharge fuel. A test connection on the filter separator sump is also required for sampling sump content and may or may not be furnished with the unit.

542-6.2.2.4 The coalescer and separator element mounting assemblies (see [Figure 542-6-3](#)) consist of a perforated metal standpipe approximately 1 inch in diameter and slightly longer than the element. One end of the standpipe is fitted with a threaded base cap to facilitate screwing it into the tube sheets. The opposite end is fitted with a threaded plug for attaching the end cap. The end cap is a metal disk approximately the same diameter as the elements. Elements that have been inspected and found to be acceptable are placed over the standpipe, and the end cap is secured in place by a bolt. A metal washer and fiber washer prevent leakage at this point.

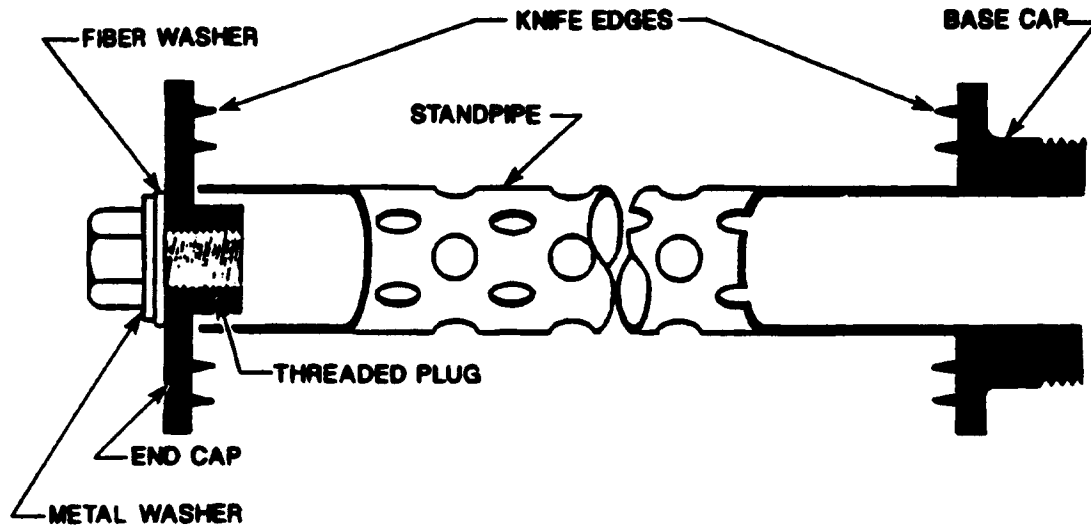

Figure 542-6-3. Filter Element Mounting Assembly

542-6.2.3 **FILTER SEPARATOR OPERATION.** During operation of the MOGAS or JP-5 filter separator, constant monitoring of the filter gages is required. Maintain a filter separator log for unit hours of operation, element replacement dates, and differential pressure. Excessive pressure can damage or rupture the coalescer elements. A drop in element differential pressure (for the same flow conditions) is an indicator of damaged elements. Start a new log when elements are changed out. Retain the last log for records.

CAUTION

Avoid draining JP-5 filter separator housing when unit is in service. JP-5 coalescer elements lose their ability to coalesce water if left in a drained, filter separator for seven days or longer. JP-5 coalescer elements shall be kept submerged to prevent accelerated deterioration (dry rot).

542-6.2.3.1 The filter separator shall be vented until a solid stream is visible in the vent line. Vent valves are then secured. For Class 1 units, operation is automatic after alignment and flow are established. Class 2 units require draining of sump before and after use. Monitoring of the sump gage glass for water accumulation is required while in use. Sample the sumps of all units (Class 1 and Class 2) before securing the pumps, to ensure that no water remains in filter bottoms.

542-6.2.3.2 Solid particles in the sump sample can indicate ruptured coalescer elements, which shall be inspected and replaced as necessary. The filter separator discharge is to be sampled frequently. Refer to [Table 542-7-1](#).

542-6.2.4 **FILTER SEPARATOR MAINTENANCE.** Review safety information in paragraphs [542-2.2.3](#), [542-2.3.2](#), and [542-2.4](#) before performing any maintenance on a MOGAS or JP-5 filter separator.

542-6.2.4.1 Filter Separator Maintenance Intervals.

The rate of flow through the filter separator and the level of contamination handled are variable; therefore, pressure drop cannot be used as the only reason for coalescer element replacement. The Planned Maintenance System (PMS) defines criteria for maintenance intervals.

542-6.2.4.1.1 Ships should deploy with new coalescer and separator elements in all filter separators. [Table 542-6-1](#) gives the percentage of spare elements required for each installed unit.

542-6.2.4.1.2 Replace coalescer elements during each regular overhaul (when filters are emptied and remain empty for more than 7 days) and under the following conditions:

- a. When fuel analysis indicates that more than 2 milligrams per liter of solids or 10 ppm of water are passing through the filter.
- b. When pressure drop across filter separator housing exceeds 15 psid.
- c. When the saturated filter elements are left in an emptied filter vessel for more than 7 days.
- d. When samples taken from the filter separator water sump contain solid particles.

NOTE

If installed and operational, MOGAS filter separator samples are taken daily when filter separator is in use.

542-6.2.4.1.3 When coalescer elements are replaced, examine the separator elements for dirt and possible Teflon damage. Test the clean separator elements, and replace only those that are defective. The Teflon-coated separator elements are considered permanent. They will function as long as they remain intact and clean.

542-6.2.4.2 Coalescer Element Removal Procedure. Remove the coalescer elements from MOGAS or JP-5 filter separator as follows:

1. Provide valve isolation and apply tag-out in accordance with the TAG-OUT USERS' MANUAL (S0400-AD-URM-010/TUM).

WARNING

Gasoline filters must be steamed out and certified safe by the Gas-Free Engineer before removing elements.

WARNING

Wear approved respiratory protection (refer to OPNAVINST 5100.19, Safety Precautions for Forces Afloat) when working in the filter housing. At all times, a man on the outside of housing shall attend personnel working in housing.

WARNING

Replacement of elements involves contact with toxic gasoline or JP-5 and their vapors. Elements that have been used in any type of fuel are a fire hazard. Remove from the compartment and place in firesafe containers for disposal. Wear protective clothing when handling elements.

2. Remove filter housing access cover(s) and gasket(s); use chain hoist and lifting lugs, if applicable. Place gasket in firesafe container. Ensure cover(s) are placed in a safe storage position.
3. Thoroughly ventilate filter housing, using air-driven blower and hose, until heavy concentration of vapor is dissipated.
4. Don approved breathing apparatus and enter housing, where necessary, and remove coalescer elements from mounts; place elements in firesafe container for disposal (refer to **NSTM Chapter 593, Pollution Control**).
5. Clean interior surfaces of coalescer side of filter housing with lint-free rags; clean center tubes with soft-bristle brush and lint-free rags. Place cleaning rags in firesafe container and remove from ship as soon as possible.

542-6.2.4.3 Coalescer Element Inspection and Replacement.

CAUTION

Exercise care not to damage or dirty coalescer element during inspection and installation. Personnel shall not touch coalescer element without having gloved hands.

At the installation site, supervisory level personnel (senior petty officer or above) shall visually inspect each coalescer element for physical damage and defects prior to installation in the filter separator. Adequate light shall be ensured, and care exercised to protect the elements from any contact with dirt, grease, and fluids. Any sign of physical damage (nicks, dents, cuts, etc.) or physical defect (gasket not properly centered, distorted center tube, gasket, or seal, etc.) shall be cause for rejection of the element. Once the element passes the visual inspection, it shall be carefully installed directly in the filter separator unit. All failed elements shall be returned to the supply point in the original packaging, and quality deficiency reports (Form 364) identifying NSN, contract number, and requisition number shall be submitted to:

Defense Construction Supply Center
Attn: Quality Assurance Director
P.O. Box 3990
Columbus, OH 43216-5000

542-6.2.4.4 Separator Element Replacement and Test. Paper separator elements are no longer specified for use. Permanent (Teflon-coated) elements are used instead. The following steps include reinstallation as well as removal, inspection, and test of the permanent elements. Observe warnings and safety precautions outlined in paragraph [542-6.2.4.2](#) and the appropriate equipment manual.

CAUTION

Separator elements and the hydrophobic dividing screen have delicate and vulnerable surfaces. The Teflon-coated screen must be protected from damage caused by hard or sharp objects. Avoid contacting screens with bare skin, particularly after separator element or hydrophobic dividing screen has been cleaned.

1. Remove separator elements from mounts, and store in a safe place until needed for cleaning and inspection.
2. Clean interior surface of separator side of filter with lint-free rags; clean center tubes with soft-bristle brush and lint-free rags.

WARNING

Wear face shield, and clear immediate area of personnel when using low-pressure air.

3. Using low-pressure air, clean hydrophobic dividing screen of all foreign matter; inspect screen for dents, punctures, and tears. Report any discrepancies to work center supervisor.
4. Wash separator elements in clean, fresh water; dry with low-pressure air.
5. Inspect elements for broken seams, dents, punctures, and foreign material. Any physical damage is cause for rejection.
6. Test permanent (Teflon-coated) separator elements (both new and used) in accordance with PMS.
 - a. Vigorously agitate element in a bath of clean JP-5 fuel to wet entire surface of Teflon screen with fuel.
 - b. Stand element on end to allow excess fuel to drain.

NOTE

Proceed with step 6 (c) within 5 minutes.

- c. Hold element in a horizontal position, preferably on a clean, dry table. Use absorbent mats, if available.

NOTE

Do not attempt to plug one end and fill unit with water in a vertical position, as leaks will occur.

- d. Pour 250-350 ml (approximately 1/2 pint) of clean, fresh water into center tube of element.
- e. Slowly rotate element and observe for water penetration or leaks. Pay particular attention to seams and end caps. Water penetrations or leaks indicate failure, and the element is not usable. Acceptable elements should be rinsed with clean fuel prior to installation.

NOTE

Submit Quality Deficiency Reports (QDR) on new elements failing test procedures.

7. Install inspected and tested elements; ensure that elements are properly positioned on each tube and tightened securely. Do not overtighten.
8. Clean access cover gasket and O-ring seating surfaces.
9. Apply a thin coat of petrolatum to new O-ring, if applicable.
10. Install new gasket(s) or O-ring; reinstall access cover(s). Tighten nuts evenly. (Refer to equipment manual for proper torque values.)
11. Shut drain valves.
12. Remove safety tags.

CAUTION

Open filter separator inlet valve slowly, to prevent rupturing filter elements.

13. Start service pump and slowly fill filter separator with fuel by cracking open inlet valve until fuel is visible in vent sight glass.
14. Shut vent valve and inspect for leaks.
15. Return equipment to normal readiness condition.
16. Place elements and cleaning rags in firesafe container for disposal (refer to **NSTM Chapter 593, Pollution Control**).

542-6.2.5 ORDERING FILTER SEPARATOR ELEMENTS. Use National Stock Numbers listed on the filter separator Allowance Parts List (APL), not manufacturer's part numbers, when ordering new elements. Stock numbers for elements are shown in [Table 542-6-1](#).

Table 542-6-1. ORDERING FILTER SEPARATOR ELEMENTS

Type	Flow	Length	National Stock Number	Deployable Service	Spares Transfer
Coalescer	Inside-to-out	20 inches	4330-00-931-2472	110%	500%
Coalescer	Inside-to-out	24 inches	4330-00-931-2473	110%	110%
Permanent type separator	Outside-to-in	17-1/2 inches	4330-00-792-6495	120%	120%
Permanent type separator	Outside-to-in	24 inches	4330-00-973-3909	120%	120%
Pre-filter	Outside-to-in	18 inches	2940-00-736-7897	120%	120%

542-6.2.6 FILTER SEPARATOR TROUBLESHOOTING GUIDE. Symptoms and corrective actions are provided for two common filter separator problems.

542-6.2.6.1 Contaminated Fuel at Service Station. Proceed as follows:

1. Check to see that the coalescer and separator elements have been installed correctly and are performing prop-

erly. Replace if necessary. Ensure that elements are securely attached to mounting assembly standpipe. Dispose of replaced elements in firesafe containers for removal to shore.

2. Check to see that the float control valve and discharge valves are operating properly. (Use the float control tester, where installed.) If they are not operating properly, proceed as follows:

CAUTION

**Do not attempt to disassemble the float control valve or to tamper with it.
Special tools and instruments are needed for assembly and adjustment.**

3. Check the flow indicator arrows on the drain and outlet valve bodies to be certain that they are properly installed.
4. Check all lines leading from the float control valve for damage. Flattened sections that restrict flow must be replaced.
5. Clean out the strainer covering the supply line port.
6. If necessary, disconnect each line and blow air through the line to ensure that all lines are free of obstruction.
7. If no defects are revealed above, remove and check the float control valve, water discharge valve, and piping. Before removal of the valve, blow air through each port with the float arm positioned to open the port. If air fails to pass through any port when the port should be open during operation, an obstruction is in the valve and the valve should be replaced.

542-6.2.6.2 Incorrect Pressure at Fueling Stations. If readjustment of the pilot valve on the automatic pressure-regulating system (LHA and some LPD ships) does not remedy this situation, a clogged service filter separator may be the cause. Check filter separator pressure drop, and replace the service filter separator elements if necessary.

542-6.3 HOSE, HOSE REELS, AND NOZZLES

542-6.3.1 HOSE DESCRIPTION AND TYPES. The hoses have a male threaded connection at one end and a female threaded connection at the other end. On ships with automatic fuel-defuel valve type aircraft fueling stations, each fueling hose (MIL-H-17902) has a full-length control wire with contacts at each end (see [Figure 542-6-4](#)). Hose lengths are connected by a special coupling so that the control wire contacts touch, completing the path from one hose length to the next. Thus, an electrical path is completed from the hose reel, through several lengths of hose, to a FUEL-DEFUEL switch on the quick-disconnect coupling (QDC) at the nozzle end of the hose. Other ship's aircraft fueling stations do not have the control wire incorporated into the fueling hose, but are provided with MIL-PRF-370 hose, which has a static wire assembled into the hose carcass to dissipate any static charge. Refer to [Table 542-6-2](#) and [Table 542-6-3](#) when ordering fueling hoses. Fueling nozzle and hose arrangements are shown in [Figure 542-6-5](#). Five types of hose are used for MOGAS and JP-5:

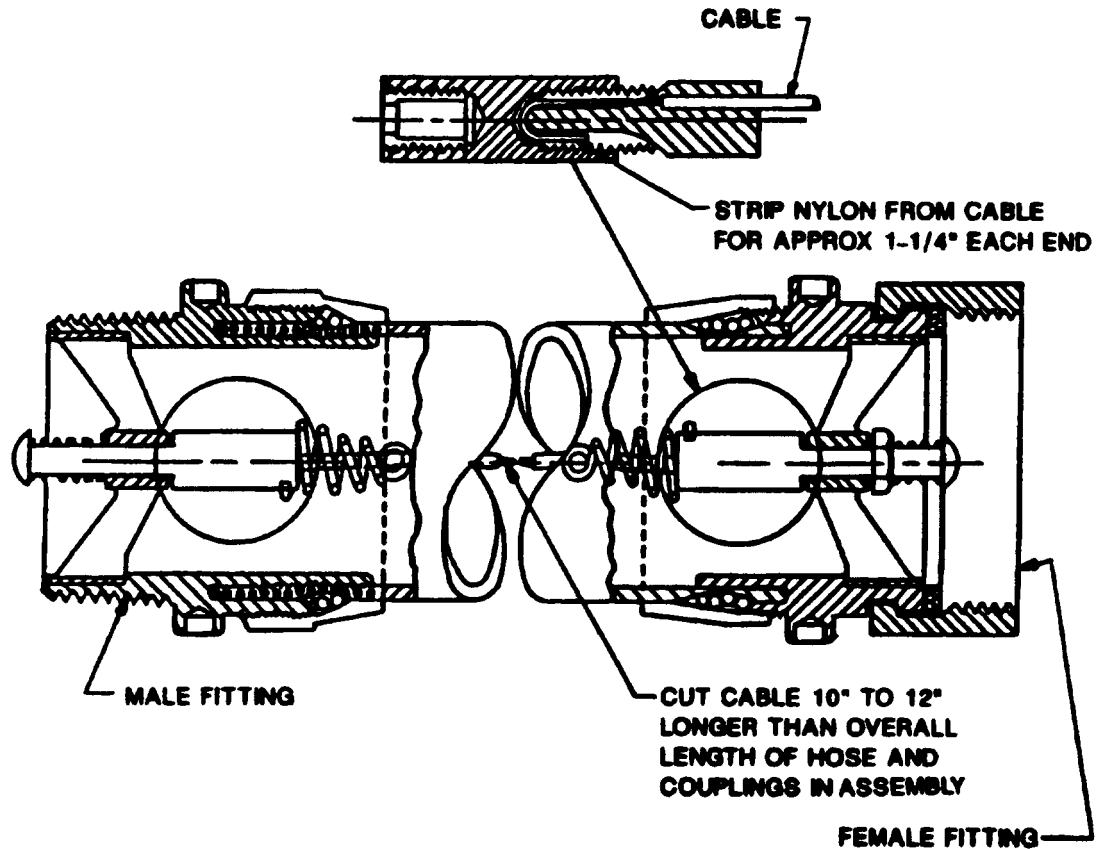

NOTE: THIS DRAWING SHOWS THE GENERAL ARRANGEMENT OF HOSE, COUPLING, AND CONTROL WIRE. IT DOES NOT PROVIDE SUBASSEMBLY DETAILS. REFER TO MIL-H-17902 FOR ADDITIONAL DETAIL.

Figure 542-6-4. Fueling Hose with Control Wire Assembly

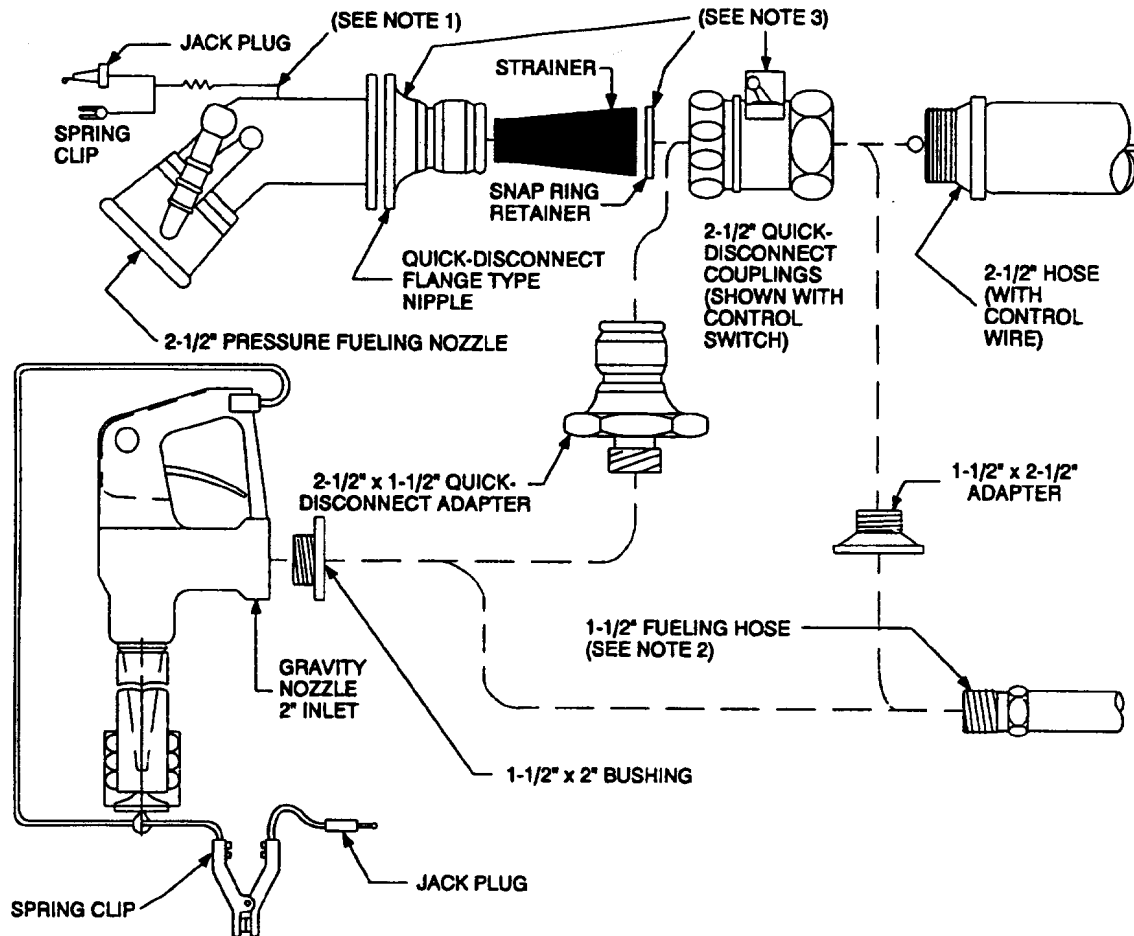
**NOTES:**

1. Grounding wire with jack plug and spring clip shown on pressure fueling nozzle is required only for HIFR fueling on air capable ships.
2. 2-1/2" hose has control wire. 1-1/2" hose is furnished with or without control wire. 1-1/2" x 2-1/2" adapter and 2-1/2" quick-disconnect coupling are available with or without provisions to suit fueling hose control wire.
3. The dry-break, quick-disconnect fuel coupling assembly, MIL-C-24788, Class II, is the only available quick-disconnect coupling assembly available in the supply system. A 60-mesh nozzle strainer is incorporated in the quick-disconnect coupling flange nipple mating to the nozzle. The retainer used in this assembly is designed for removal by hand without the necessity of tools.
4. Refer to Table 542-6-2 and Table 542-6-3 for hose and fitting ordering information.

Figure 542-6-5. Fueling Nozzle and Hose Arrangements

Table 542-6-2. ORDERING FUELING HOSTS AND HOSE END FITTINGS

Specification	Description	National Stock Number (NSN)
MIL-H-17902/B-CCA-50	2-1/2-inch, collapsible hose assembly, 50 feet	4720-00-289-0756 (open solicitation for procurement)
MIL-H-17902/B-CCA-50	2-1/2-inch, collapsible hose assembly, 50 feet	4720-01-270-5801 (Durodyne)
MIL-H-17902/B-CCH-50	2-1/2-inch, collapsible hose only, 50 feet	4720-01-254-0191
MIL-H-17902/A-NCA-50	1-1/2-inch, non-collapsible hose only, 50 feet	4720-00-826-4782
MIL-H-17902/B-FM	2-1/2-inch, male fitting	4730-01-242-2832
MIL-H-17902/B-FF	2-1/2-inch, female fitting	4730-01-242-7734
MIL-PRF-370	1-1/2-inch, non-collapsible hose assembly, 50 feet	4720-00-289-1409
MIL-PRF-370 (formerly A-A-52554)	3/4-inch, non-collapsible hose assembly, 20 feet	4720-01-274-9234

Table 542-6-3. ORDERING FUELING HOSE ACCESSORIES

Description (From Figure 542-6-5)	Specification	National Stock Number (NSN)
Nozzle quick-disconnect flange-type nipple	MS26549	4730-00-114-0913
Strainer	MS26551-2	----
Snap-ring retainer	NAS-669-225	----
Strainer & retainer (set)	----	4730-00-886-8203
2-1/2-inch X 1-1/2-inch Quick-Disconnect Adapter	MS26552-4	4730-00-759-2975
1-1/2-inch X 2-inch Bushing	MS51847	4730-00-268-7479
1-1/2-inch X 2-1/2-inch Adapter (with control spider)	----	4730-00-674-8311
1-1/2-inch X 2-1/2-inch Adapter (without control spider)	----	4730-01-136-2457
N/A	OPW 1-inch refueling nozzle	4930-01-441-1313
2-1/2 inch dry-break quick disconnect coupling	MIL-C-24788	4730-01-466-5963 (P/N 64155)
2-1/2 inch hose gasket (MIL-H-17902)	MIL-R-6855	5330-01-325-9970
1-1/2 inch hose gasket (MIL-H-17902)	MIL-R-6855	5330-01-325-1996

- a. The transfer and filling hose is used to deliver JP-5 to the ship's receiving connections from a barge or tanker. The transfer and filling hose is a fuel-resistant, oil-proof, synthetic-rubber tube, reinforced by alternating layers of fabric and rubber, and is available in sizes 2-1/2-inch, 4-inch, 6-inch, and 7-inch diameter.
- b. A 2-1/2-inch collapsible MIL-H-17902 hose is used for JP-5 fueling of aircraft and, if necessary, for defueling. When emptied of fuel, the collapsed hose will flatten throughout its length. It can then be coiled flat on the aircraft fueling hose reel.
- c. A special lightweight 2-inch hose with unisex dry-break fittings is used for helicopter fueling on air-capable ships. Two sections of hose are provided; 100 feet non-collapsible, 100 feet collapsible. Both hose sections incorporate static-bond wires.
- d. Non-collapsible MIL-H-17902 hose, available in 1-1/2-inch size is the hose type for JP-5 defueling. This hose consists of fuel-resistant, oil-proof, synthetic-rubber inner and outer covers, separated by alternating layers of impregnated cotton cord and synthetic rubber, and a helix coil of wire to prevent collapse.
- e. The fifth type hose is a non-collapsible rubber hose (MIL-PRF-370, formerly A-A-52554) available in 1-1/2-inch and 3/4-inch size for the JP-5 auxiliary service system fueling stations and MOGAS applications. Ships using

3/4-inch hose may utilize an adapter to mate to the 1-1/2-inch gravity nozzle, see [Figure 542-6-6](#).

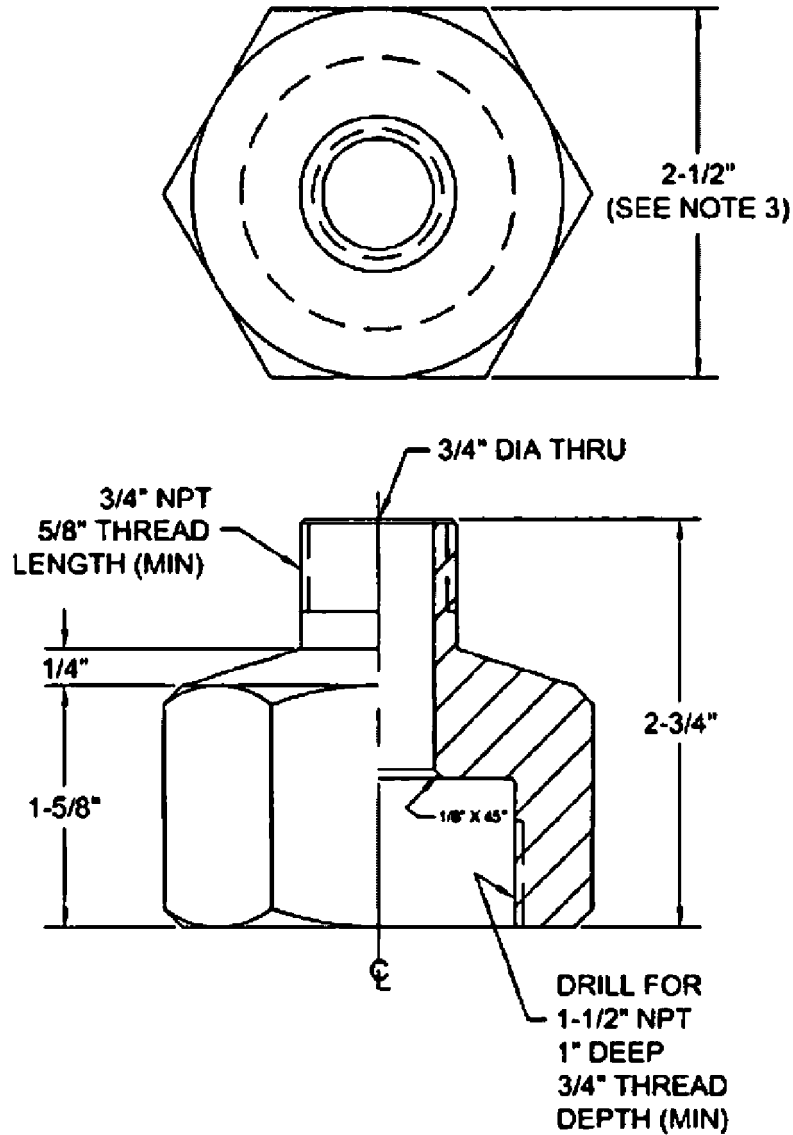

NOTES:

1. HYDROSTATIC TEST PRESSURE TO BE 150 PSI, HELD FOR 5 MINUTES.
2. ALTERNATE MATERIALS SHALL BE SUITABLE FOR USE IN JP5 FUEL SYSTEMS.
3. HEX SIZE MAY BE ADJUSTED TO SUIT AVAILABLE HEX BAR OR ROUND STOCK
4. BREAK ALL SHARP EDGES.

1	ADAPTER	1	AS REQ	CU ALLOY	ASTM B271	CU ALLOY 95500 OR SIMILAR
P/N	DESCRIPTION	QTY	STOCK	MATL	MATL SPEC	NOTES
PREPARED	F PARK	2/22/06	NAVAL AVIATION DEPOT, NORTH ISLAND			
CHECKED			CVN 68			
APPROVED			JP5 AUXILIARY FUELING HOSE ADAPTER			
TOLERANCES, UNLESS OTHERWISE SPECIFIED FRACTIONS: ±1/64, DECIMALS ±.010, ANGLES: ±1/2°				CODE IDENT. NO. 91145	SK160714	SHEET 1 OF 1

Figure 542-6-6. JP5 Auxillary Fuel Hose Adapter

542-6.3.2 PREPARING JP-5 FUELING HOSE FOR USE. Before placing a new JP-5 fueling hose in service or installing an older hose, hydrotest and flush the hose in accordance with the following procedures:

CAUTION

If the following action is taken, and a hose still delivers a higher than allowable contamination level, do not use for fueling aircraft. Request disposition instructions from Commander, Naval Sea Systems Command.

1. Unpack hose and visually inspect hose for damage.
2. Hydrotest hose to 150 percent of working pressure.
3. After hydrotest, extend hose to its full length, and elevate to drain water.
4. Install hose, place on hose reel with other new hoses or in-use hoses, and commence flushing. Flush until samples do not exceed the maximum allowed contamination of 2 milligrams per liter solids and 10 parts per million (ppm) water.
5. Hose is now ready for use.

542-6.3.3 JP-5 FUELING HOSE OPERATING PRECAUTIONS. The following precautions are for safety as well as prolonged hose life:

1. Be careful not to twist or kink the hose when removing it from a reel. Because of its length, aircraft fueling hose is likely to become twisted.
2. Avoid exposing the hose to excessive abrasion, especially when passing the hose over the edge of the flight deck.
3. Avoid exposing the hose to direct jet engine exhaust.
4. Always restow hoses on designated hose reels at the completion of refueling operations. Improperly stowed hoses could cause internal or external damage.

542-6.3.4 HOSE INSPECTION AND MAINTENANCE. Hoses shall be inspected periodically to test the static bond or continuity circuit and to check for physical damage.

542-6.3.4.1 Hoses shall be inspected in accordance with PMS requirements to test the static wire continuity of MIL-PRF-370 hose and HIFR hose or the continuity circuit of MIL-H-17902 hose. Lack of continuity in the MIL-PRF-370 or HIFR hose may indicate that the hose has stretched enough to break the static wire, making the hose unsuitable for use.

542-6.3.4.2 Inspect the fueling hose periodically for superficial cuts or abrasions, deeper cuts that expose the reinforcing wire, bulges, blisters, general swelling, extensive fraying of the fabric, and loosening of the interior tube. Salvage fuel hose damaged near an end coupling, but otherwise usable, by back-cutting as follows:

1. Disconnect and remove spiders and control wire from hose.
2. Clamp spanner type coupling into jig similar to that shown in [Figure 542-6-7](#). (Jig not required for hex-type

coupling.)

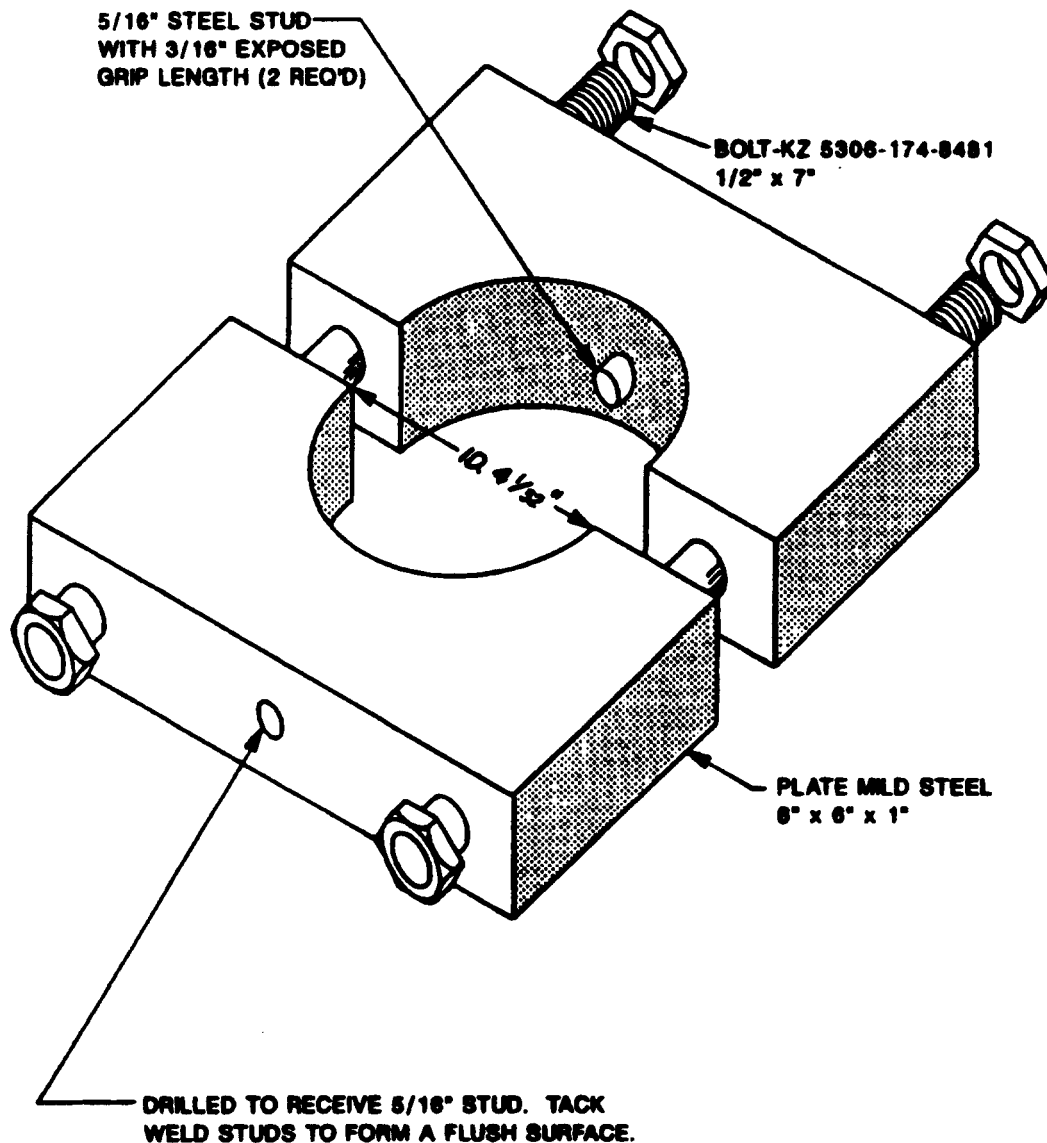

Figure 542-6-7. Fueling Nozzle and Hose Arrangements

3. Remove reusable hose coupling.
4. Slide external taper sleeve of the coupling back past damaged area. Ensure that hose is squared up and mark hose for cutting, using sleeve as a guide. Remove taper sleeve after marking hose.
5. Cut fabric-reinforced hose with a sharp knife wetted with fresh water. Cut wire-reinforced hose with a high-speed cutting abrasion wheel if available. If an abrasion wheel is not available, use a new or sharp hacksaw with fine teeth. Insert a round wood plug into the hose to eliminate danger of loosening inner liner or damaging wire reinforcement while cutting.
6. Paint the freshly cut hose end lip with a light coat of epoxy MIL-P-24441 or MIL-P-23236B primer to provide a moisture barrier.
7. Slide external taper sleeve back on hose.
8. Slide on wire helix (spiral) about 6 inches back from end of hose.
9. Insert coupling end into hose, ensuring hose is bottomed at lip.

10. Work helix into position, being careful not to overexpend helix.
11. Slide external taper sleeve into position and tighten.
12. Hydrostatically test hose per MRC.
13. Flush hose, with product to be used for service, until a clear sample is obtained.

WARNING

Remove pressure by bleeding test fluid slowly.

14. Cut control wire 10-12 inches longer than hose to absorb hose stretch.
15. Reinstall control wire and spiders. Check for electrical continuity between the contact buttons at the hose ends using an ohmmeter. Maximum allowable reading is 40 ohms.

542-6.3.5 HOSE REELS. Two types of hose reels used for storage of fueling hose are manually operated and capable of handling 150 feet of 2-1/2-inch hose. Up to 400 feet of 1-1/2-inch non-collapsible hose can be stored on the wider type reels. The reel discharge fitting has a spider with an electrical contact at the center, to bear against a similar contact button in the hose. From this contact on the discharge fitting, there is a continuous electrical path through the center of the hose reel to a terminal on the stationary part of the reel, at the inlet connection. The electrical circuit through the reel is insulated electrically from the reel.

542-6.3.6 FUELING NOZZLES. Four types of nozzles are used in fueling operations. The gravity fueling nozzle, the D-1 or D-1R pressure fueling nozzle, the OPW gravity nozzle, and the closed circuit refueling (CCR) nozzle.

542-6.3.6.1 Gravity Fueling Nozzle. The MD-3 (MIL-N-87963) gravity nozzle (see [Figure 542-6-8](#)) is used for MOGAS fueling of combat vehicles; for JP-5 fueling of combat vehicles, ship's boats, or support equipment; and for refueling aircraft when other nozzles are not appropriate. The gravity nozzle (MIL-N-87963) is attached to the fueling hose with suitable adapters, depending on hose type, and a 1-1/2- x 2-inch bushing that screws into the nozzle inlet. Either a flexible or a rigid tube, fitted with an adapter, screws into the discharge end of the nozzle. A grounding wire on the nozzle fastens to a metal part of the aircraft or vehicle with a clamp or a jack plug.

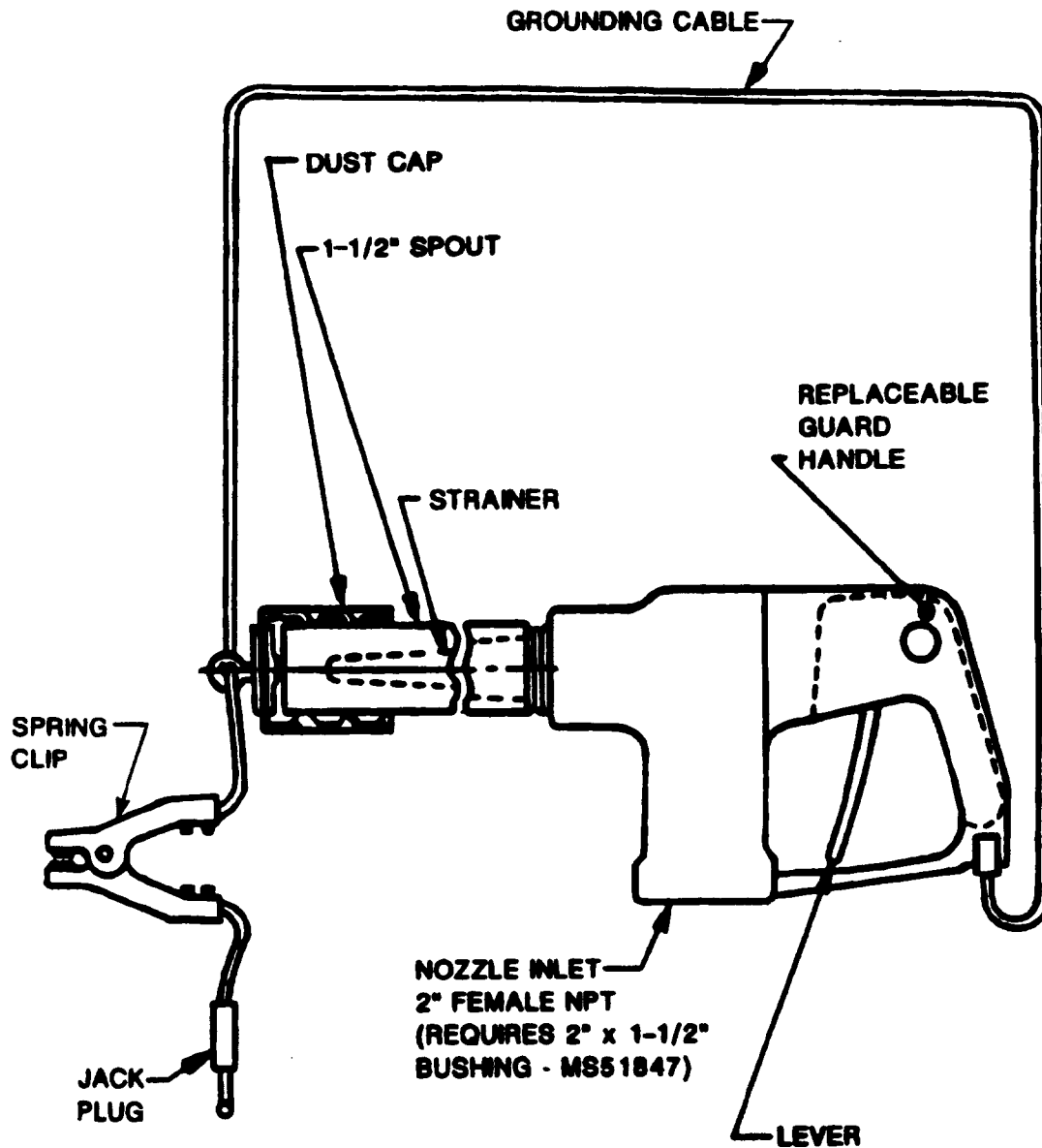

NOZZLE: NSN 4930-01-022-7901

Figure 542-6-8. Gravity Fueling Nozzle

542-6.3.6.1.1 Squeezing the control lever upward against the body of the nozzle allows the fuel to flow. The dual valve allows for gradual opening or closing. The control lever presses against the end of the valve stem and lifts the upper valve disc, which is held against its seat by the compression spring. The spring is held against the disc flange by the removable cap. Opening the smaller valve prevents a sudden flow of fuel and is known as cracking the valve. After cracking, continued squeezing of the handle depresses the valve stem further, and the flange on the stem meets the lower valve disc assembly. When the lower valve is open, full flow of fuel is obtained.

542-6.3.6.1.2 When the control lever is released, the operation is reversed, and the lower valve closes first. The small stream still coming through the upper valve relieves stress on the hose that would result if the complete flow were suddenly stopped. The smaller valve closes after the large disc seats, and the nozzle is then completely closed.

542-6.3.6.2 D-1 and D-1R Pressure Fueling Nozzle. The D-1 pressure fueling nozzle (SAE AS5877) is designed for high-capacity fueling operations, both to supply fuel under pressure to aircraft (and LCACs), and to remove fuel by suction via the ship aviation fuel system. This nozzle (see [Figure 542-6-9](#)) is the primary nozzle used for on-deck JP-5 fueling of aircraft aboard Aviation ships. The D-1R nozzle is equipped with a hose-end pressure control valve (HEPCV), (see [Figure 542-6-10](#)). The D-1R nozzle is the primary nozzle used for on-deck JP-5 fueling of aircraft aboard Air Capable ships. Complete details on the operation of the nozzle are contained in the operating manual supplied with each nozzle.

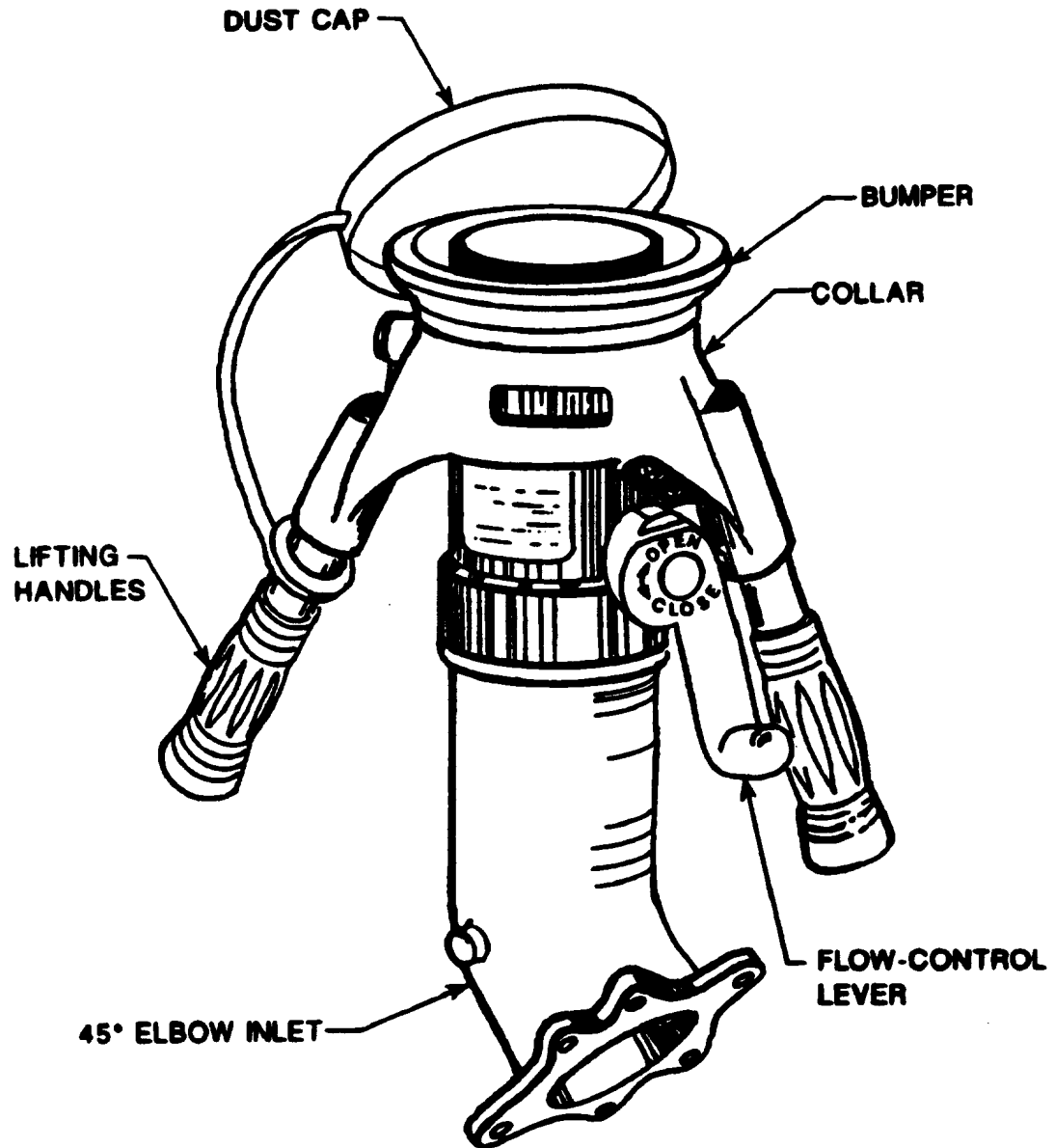

NOZZLE: NSN 4930-00-310-4858 (Generic NSN)
NSN 4930-01-385-8946 (JC Carter nozzle)
NSN 4930-01-458-5914 (Whittaker nozzle)

Figure 542-6-9. Pressure Fueling Nozzle

542-6.3.6.2.1 The nozzle is attached to the hose via a flanged nipple adapter and a quick-disconnect coupling. The nozzle outlet attaches solidly to the aircraft's SPR adapter. The nozzle can be secured properly to the aircraft's SPR fueling adapter by one person. The D-1/D-1R pressure refueling nozzle is attached to the hose with the nozzle flow control handle in the OFF (no flow) position. When the D-1/D-1R nozzle is attached to the aircraft SPR fueling adapter, the nozzle interlock is engaged and the nozzle flow control handle can be rotated to the ON (flow) position. With the nozzle flow control handle in the ON position, the D-1/D-1R nozzle cannot be removed from the aircraft SPR fueling adapter. The D-1/D-1R pressure refueling nozzle can be replaced with a gravity refueling nozzle by using suitable adapters.

542-6.3.6.2.2 Each pressure nozzle has a plugged sampling port to accept a sampling coupler and actuator assembly designed for obtaining fuel samples during fueling. The sampling assembly consists of a quick-disconnect coupler and the actuator used to draw samples. The actuator plugs into the coupler, which is threaded into the nozzle sampling port.

542-6.3.6.2.3 If a coupler fails, pieces of the coupler may get into aircraft fuel lines. To prevent this, only sampling assemblies that have proved to be satisfactory shall be used. Non-swivel type nozzles utilize GTP 234-1/4-AND couplers (NSN 4730-01-135-7461). Swivel-type nozzles utilize GTP 235-3/8-NPT couplers (NSN 1730-01-228-5410). The actuators are GTP-423 (NSN 4820-01-170-7087).

542-6.3.6.2.4 A hose end pressure control valve (HEPCV) has been introduced into the fleet to protect the aircraft when the 55-psig delivery pressure cannot be controlled otherwise. The HEPCV attaches to or is integral to the D-1 nozzle. A D-1 nozzle with an HEPCV is designated as a D-1R nozzle (see [Figure 542-6-10](#)).

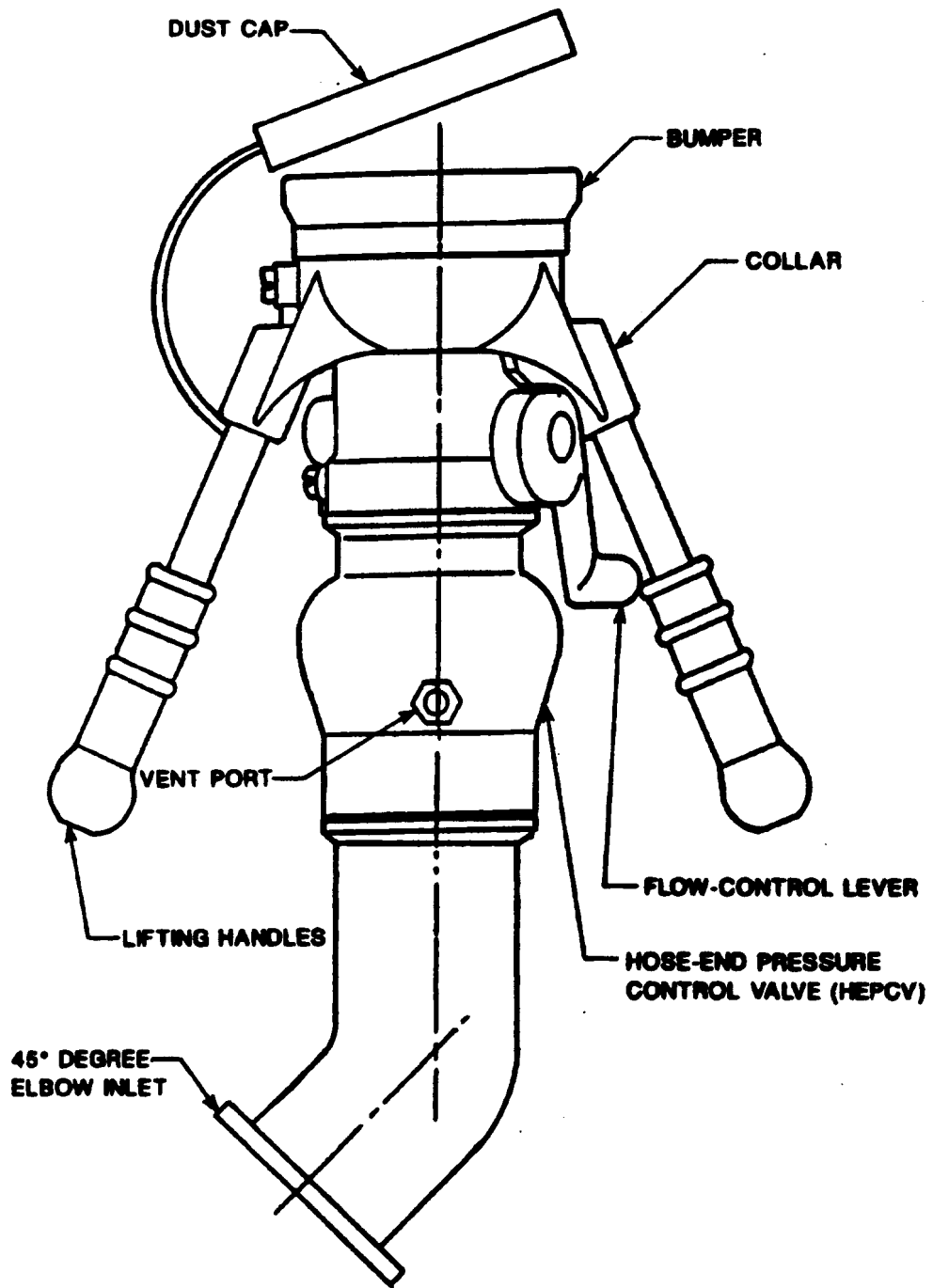

NOZZLE: NSN 4930-01-385-8991 (JC Carter D-1R nozzle)

Figure 542-6-10. D-1R Pressure Fueling Nozzle (with HEPCV)

542-6.3.6.3 OPW Gravity Nozzle. The OPW gravity nozzle (see [Figure 542-6-11](#)) can be used on shipboard JP-5 auxiliary service system boat and tractor fill stations and in MOGAS fueling operations along with MIL-PRF-370, 3/4-inch hose and end adapters. The nozzle comes equipped with a 100-mesh strainer, ground wire clip, dust cover and is lightweight and durable. A surge suppression design prevents spillage. This nozzle shall not be equipped with an automatic hold open characteristic for hands-off refueling.

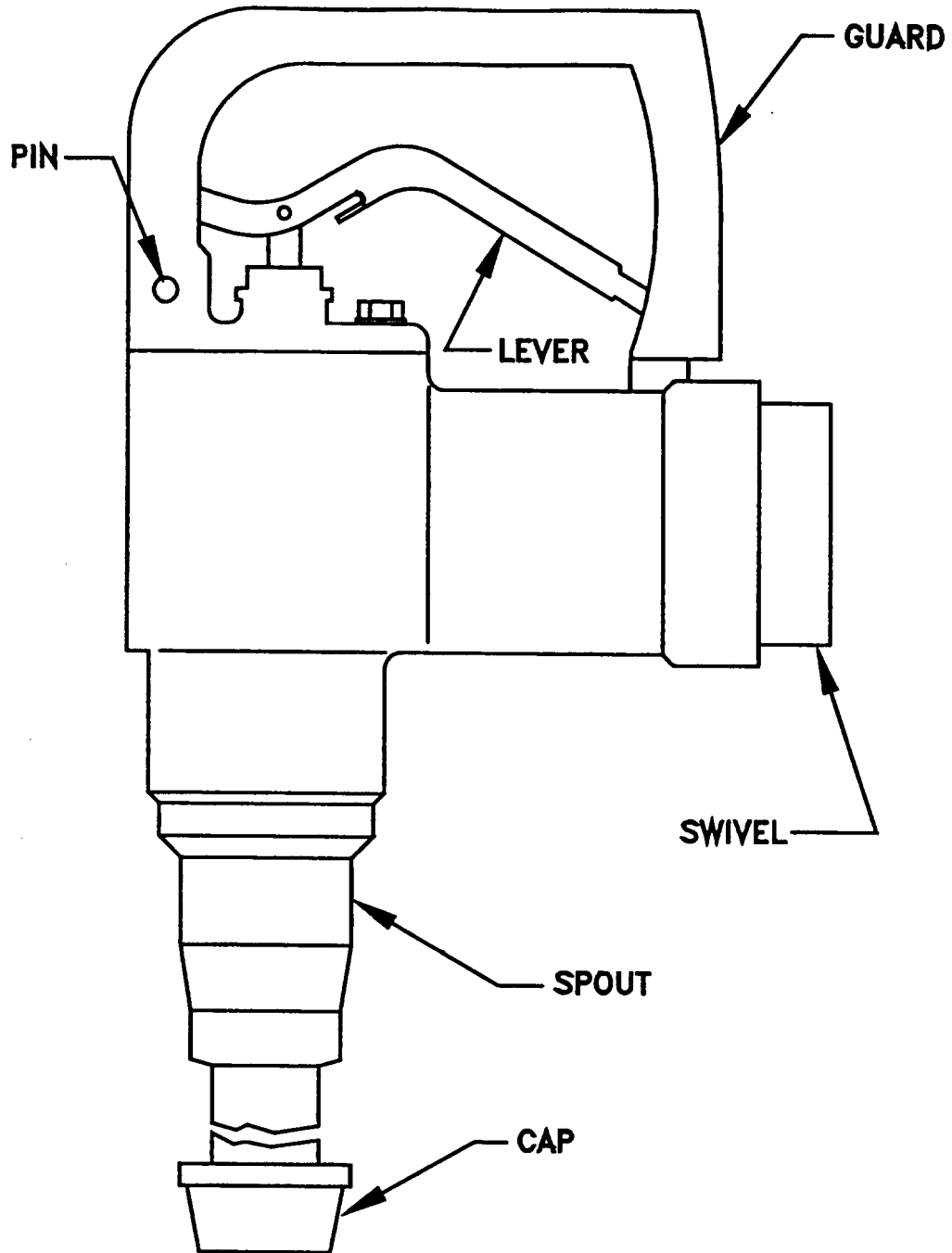

NOZZLE: OPW 295SA-135
NSN 4930-01-441-1313

Figure 542-6-11. OPW Gravity Nozzle

542-6.3.6.4 CCR Nozzle. The closed-circuit refueling (CCR) nozzle is furnished primarily to air capable ships for HIFR operations. The CCR nozzle (see [Figure 542-6-12](#)) is equipped with a quick-disconnect, automatic-shutoff coupler for direct connection to the aircraft POL series fueling adapter. The nozzle includes a ground cable assembly, a dust cap for the inlet fitting, and a dust plug or cap for the coupler. The CCR nozzle includes an integral means to regulate pressure at 45 +/- 5 psig when the nozzle is connected to the helicopter POL (HIFR) adapter. Approved CCR nozzles are Aeroquip model AE87548R and JC Carter model 64048B.

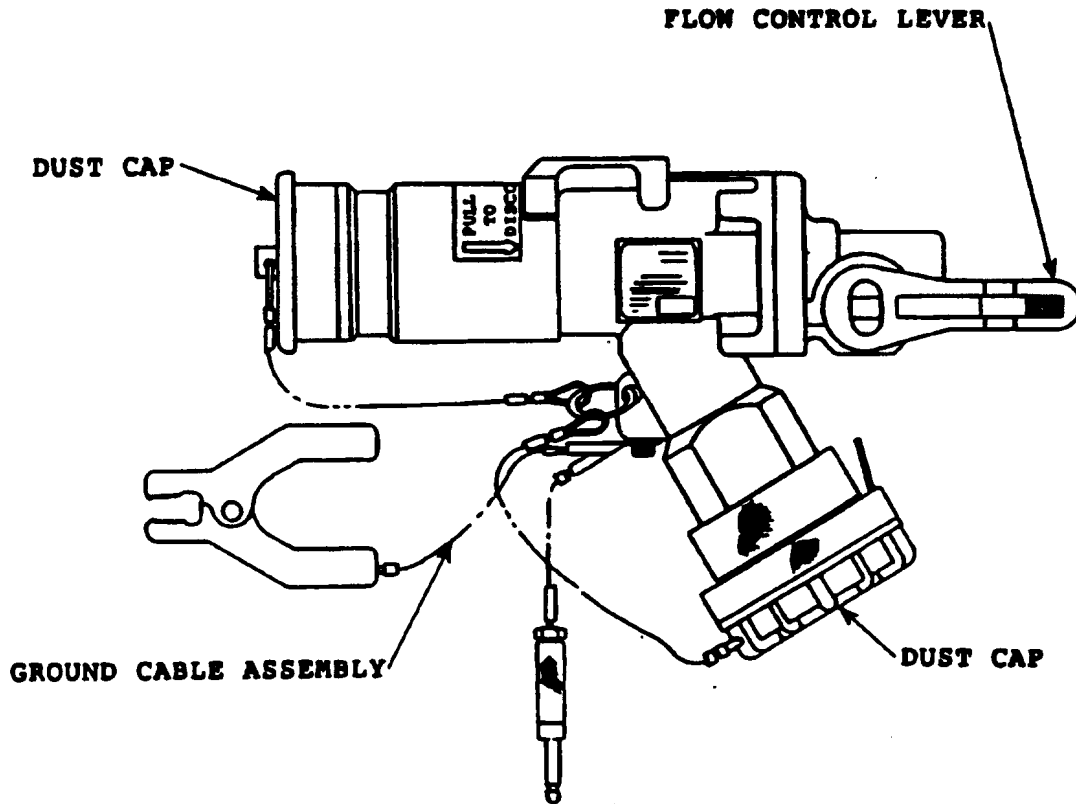

NOTE: The CCR nozzle, Aeroquip AE87548R or JC Carter 64048B, is equipped with a spring to regulate pressure to 45 psig +/- 0 psig.

Figure 542-6-12. Closed-Circuit Refueling (CCR) Nozzle

542-6.3.7 HOSE END PRESSURE CONTROL VALVE. The HEPCV is designed specifically to prevent excessive pressures in the aircraft in the aircraft fuel piping. The HEPCV is installed at the pressure nozzle inlet (see [Figure 542-6-10](#)) where it is close enough to the fast-closing aircraft valves to respond quickly to keep destructive pressure surges from developing. With the intention of the HEPCV to protect the aircraft's internal fuel system, pressure surges could be subjected to the refueling hose assembly. It is imperative that diligent hose maintenance is conducted, per paragraph [542-6.3.4](#), to prevent hose assembly failures. When pressure at the HEPCV inlet approaches the HEPCV pressure setting, an internal spring/piston arrangement reacts to reduce flow area in the HEPCV, thus limiting the outlet pressure from exceeding the set pressure. As the excessive inlet pressure decreases, the spring returns the piston assembly toward the full-open position, automatically returning the HEPCV to the normal, unregulated condition.

542-6.3.8 UNISEX COUPLINGS. Unisex coupling halves provide easy connection of fuel nozzles, hoses, and adapters used with the new HIFR rigs. The unisex design means a coupling half can be connected to another identical coupling half.

542-6.3.8.1 Each unisex coupling half (see [Figure 542-6-13](#)) has a two-position handle for FLOW or NO FLOW. Connecting or disconnecting is only possible when the handles of both coupling halves are in the NO FLOW position. At NO FLOW an internal valve is locked closed to prevent fuel spillage. At FLOW the internal valve is locked open to allow full flow with minimum pressure loss. An interlock pin locks the coupling halves together to prevent accidental disconnection and fuel spillage.

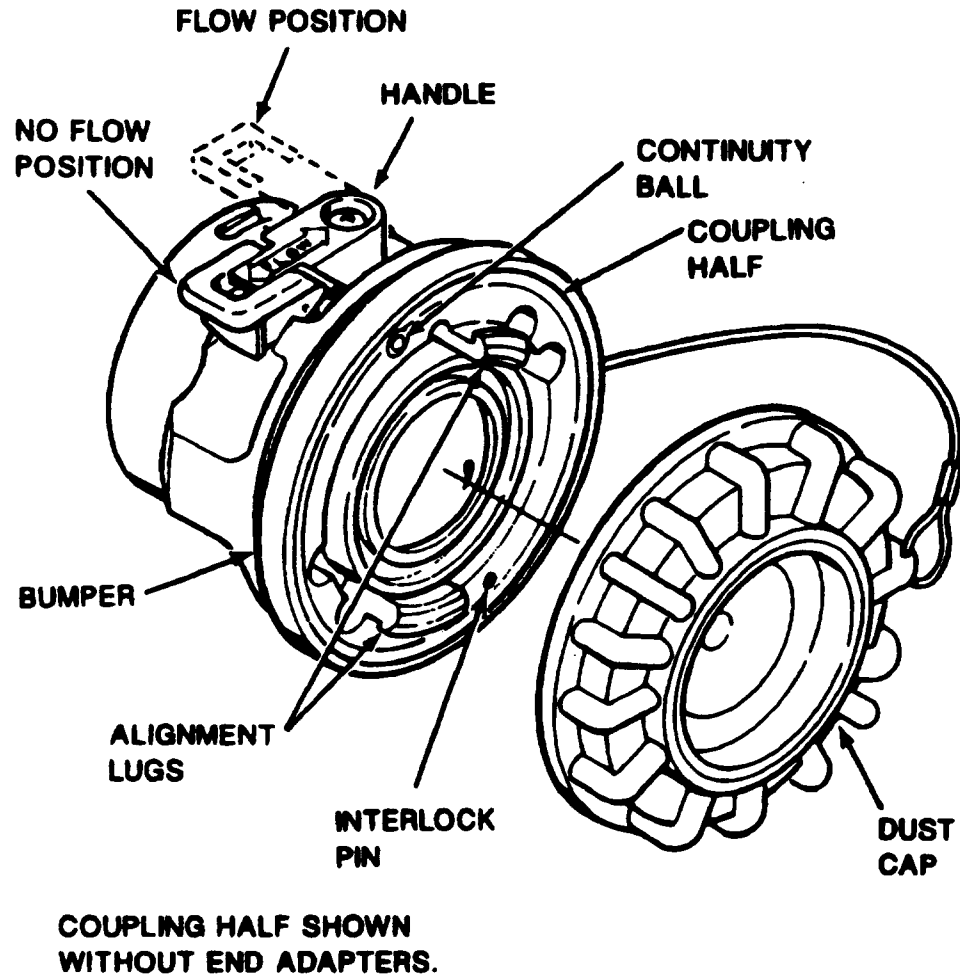

Figure 542-6-13. Unisex Coupling

542-6.3.8.2 An external rubber bumper protects the coupling half, if dropped or pulled across the ground, and acts as a dust seal when the coupling is connected. The dust cap prevents contamination when the coupling is disconnected.

542-6.4 FUELING-AT-SEA RIGS

542-6.4.1 GENERAL. Fueling-At-Sea (FAS) is transferring fuel from one underway ship to another on the open sea. Three types of FAS rigs are used by the fleet: probe and receiver, quick-release coupling with breakable spool, and combined quick-release coupling and valve (Robb Coupling). Most FAS components, including hose, hose fittings, adapters, reducers, probes, valves, and clamps are standard stock items. For MIL-SPEC and NSN information pertaining to these components, and for detailed descriptive and operating information on these three fueling-at-sea rigs, refer to **NSTM Chapter 541, Ship Fuel and Fuel Systems**.

542-6.4.2 PROBE AND RECEIVER. The probe is the primary method of fueling at sea and has been adopted as the standard method by the North Atlantic Treaty Organization (NATO). The fuel hose is suspended from a spanwire between two ships. The spanwire, having been passed from the delivery ship to the receiving ship, is connected to the pelican hook of the receiving ship's swivel arm. The probe, riding on trolleys supported from the spanwire, is inhailed by the receiving ship until it locks into the receiver. After fuel delivery, the probe can be manually disconnected by pulling down on the receiver's release lever. An emergency quick-release feature is also provided, if needed at any time during fueling.

542-6.4.3 QUICK-RELEASE COUPLING WITH BREAKABLE SPOOL. This rig is required when transferring fuel to NATO ships that are not equipped with the probe receiver. The coupling is made of two parts called A-end and B-end. The A-end is cast iron, grooved circumferentially to ensure breaking under a sharp blow, and is held by the receiving ship. The B-end is passed over by the delivery ship on the end of the hose. A specially slotted floating ring flange, with gasket fitted into the B-end, minimizes the time required to couple the hose. If an emergency quick release is necessary at any time during fueling, the A-end is struck a sharp blow with a 10- or 12-pound sledge to break it around the groove.

542-6.4.4 COMBINED QUICK-RELEASE COUPLING AND VALVE (ROBB COUPLING). The Robb coupling provides an alternative to hose connection by the probe or breakable spool. With the Robb coupling, the male end (nipple) is bolted to the standard fueling manifold flange on the receiving ship. The female part is sent over with the hose. After fueling, the coupling can be manually disconnected by retracting the spring tension sleeve.

542-6.4.5 SAFETY PRECAUTIONS. As no physical handling of the hose is required, personnel should stand clear during connect-up, fuel transfer, and breakaway. Control the travel of the probe down the spanwire to prevent the probe from striking the receiver with undue force.

542-6.4.6 BLOWDOWN OF THE HOSE. Blowdown or back suction is not required after fuel delivery with the probe rig but is required after using the breakable spool or Robb connections.

542-6.5 AVIATION SHIP JP-5 PURIFIERS

542-6.5.1 GENERAL INFORMATION. Alpha-Laval Model B-214 series centrifugal purifiers are provided in accordance with MIL-P-22088 for CV, CVN, LHA and LHD aviation type ships. The purifiers remove water and solids from the JP-5 during fuel transfer from storage tanks to the JP-5 service system. Consult the appropriate NAVSEA technical manual before operating purifiers. Refer to S9542-AB-MMO-010, **JP-5 Jet Fuel Centrifugal Purifier** for Model B-214A or S9266-AL-MMM-010, **Ships' Fuel Purifier** for Model B-214AS/B-214AS300, or S9542-AE-MMO-010, **JP-5 Jet Fuel Centrifugal Purifier** for Model B214AS-300. JP-5 is supplied to the purifier by a 200 to 300 gpm transfer pump. The purifier has a capacity of 200 to 300 gpm. It is a constant efficiency separator since the accumulated solids are stored away from the separation zone. Separation occurs within disk spaces and the liquid discharge from the outlets is removed from the interferences of stored solids.

542-6.5.2 PURIFIER DESCRIPTION. The unit consists of a frame, bowl cover, bowl, paring disk, and a driving mechanism. The frame is bolted to a base plate which is in turn bolted to the deck. All running parts and the drive mechanism are attached to the frame. The bowl casing and the lube-oil reservoir are parts of the frame. The bowl cover is connected to the bowl casing by a cover hinge which includes inlet and outlet connections. The

bowl is self-draining. Liquid drains from the bowl into the frame bowl casing and is then piped to a drain tank. The paring disk pumps the purified jet fuel from the bowl.

542-6.5.3 PURIFIER AUTOMATIC SHUTOFF. Purifiers provided on LHD Class ships are equipped with a vibration switch which will activate if excessive vibration occurs within the purifier securing power to the controller and the purifier. For CV/CVN ships with 300-gpm models, a pressure switch is installed in the clean fuel discharge piping and connected to a programmable Navy logic controller (PNLC). The PNLC is energized when the pressure switch senses 15 psi in the purifier discharge piping and will secure power to the transfer pump controller in use if pressure drops below 10 psi. An audible alarm will sound should this occur.

542-6.5.4 PURIFIER PRINCIPLES OF OPERATION. Dirty JP-5 enters the top of the revolving bowl through the regulating tube. It then passes down the inside of the tubular shaft and out at the bottom, into the stack of disks. As the fuel flows up through the holes in the disks, the force exerted by the revolving bowl causes the dirt, sludge, and water to move outward and the purified jet fuel inward towards the tubular shaft. The disks divide the space within the bowl into many separate narrow passages to avoid agitation of the liquid and increase purifying efficiency. Most of the dirt and sludge remains in the bowl and collects on the inside vertical surface of the bowl shell. Water, along with some dirt and sludge, is discharged over the ring at the top of the bowl. The purified jet fuel is picked up by the paring disk and carried away (see [Figure 542-6-14](#)) Careful selection of the proper discharge ring is essential. The specific gravity of the fuel determines the size of the ring.

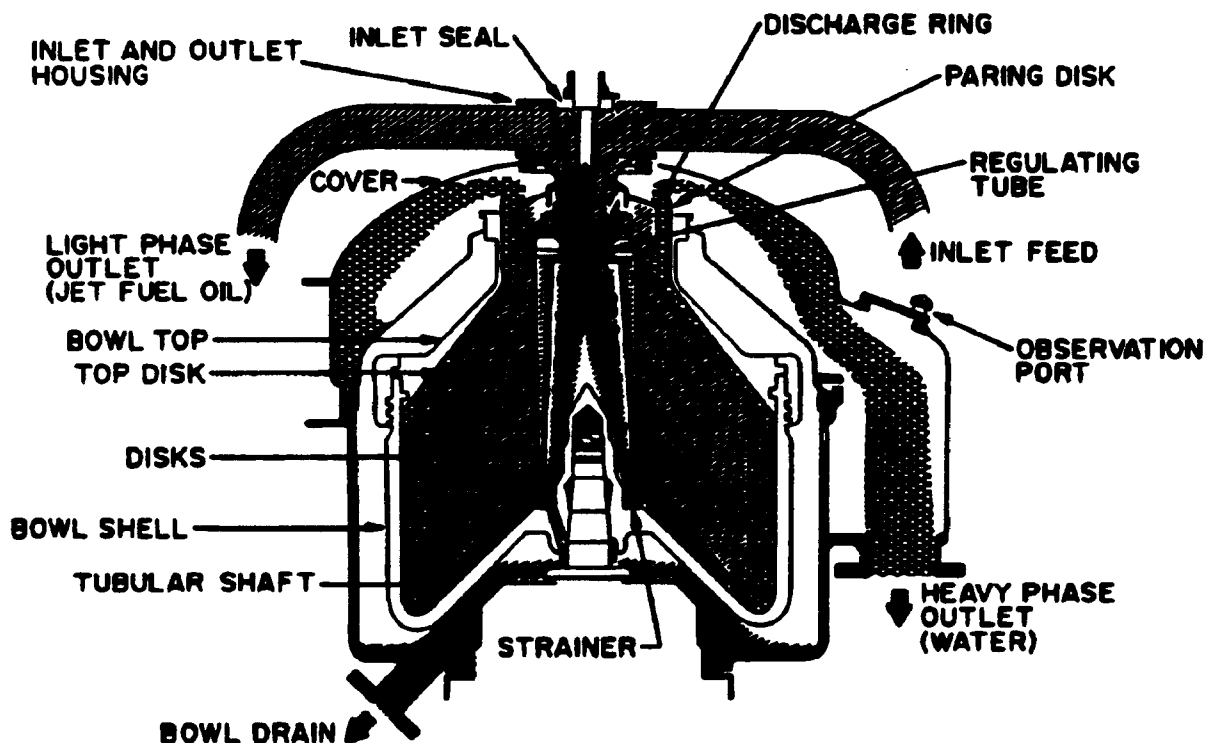

Figure 542-6-14. Flow and Operation of Purifier (B-214) Bowl

542-6.5.5 PURIFIER OPERATING PRECAUTIONS. Observe the following operating precautions:

CAUTION

Be sure purifier drain tank is empty prior to starting purifier. Overfilling drain tank will necessitate changing of purifier oil. The drain tank alarm will sound at about 60 percent capacity.

CAUTION

Priming the bowl with water at the start of each run is essential to operation of the purifier. Priming water shall be introduced when the purifier motor is energized and secured when water discharges through the observation port. Priming water shall be introduced if purifier is running in standby.

1. Mount the machine firmly. All connections to and from it must be tight and leakproof.
2. Keep the entire machine clean and, in particular, clean the hole and driving bushing in the bowl shell and the end of the spindle before assembling.
3. Use the proper size discharge ring.
4. Be sure all rubber rings and seals are assembled in their respective places and that the regulating tube and paring disk are secured to the inlet assembly.
5. Before each assembly, lubricate contact areas and the threads of the bowl coupling ring, bowl shell, and coupling nut.
6. .Before starting, be sure bowl lock screws are backed out, plugs are inserted, cover clamps are tight, and the valves are properly aligned.
7. Occasionally, check bowl speed with indicator; never open covers while bowl is running.
8. Check oil level. Use grade 80W-90 oil MIL-L-2105.
9. Do not apply brake except in emergency. Be sure brake is off before starting.
10. If the machine does not come up to operating speed within 10 to 13 minutes after starting, shut it down and determine the cause.

CAUTION

Frequent restarts may damage the purifier motor. Do not attempt to restart within 1/2 hour after rotation wind-down. If purification is to be performed again within 1/2 hour, unit is to be placed into standby mode rather than shutting down. Induce priming water during standby modes.

542-6.5.6 PLACING THE PURIFIER IN STANDBY. While the purifier is in standby, JP-5 to the purifier is secured, and normal operating speed (rpm) is maintained. When required, place the purifier into standby mode according to the following procedure.

WARNING

The following procedure shall be followed without deviation to prevent overheating of the inlet and outlet housing materials. If it is not possible to conduct the following sequence of operation, the purifier shall be shut down and not restarted for at least 1/2 hour after rotation wind-down.

1. Stop the JP-5 transfer pumps.
2. Shut the purifier inlet valve.
3. Open the prime-water valve manually and admit a trickle of water to the unit. Open the observation port to confirm water flow.
4. At 5-minute intervals, verify running condition to ensure that the purifier inlet/outlet housing and cover are cool (no discomfort) to the touch.
5. If the inlet/outlet housing or cover are hot to the touch, increase the flow of prime water (a hot cover or inlet/outlet housing should become cool within 10 seconds). If the cover or inlet/outlet housing does not become cool, secure the purifier.

542-6.5.7 PURIFIER MAINTENANCE. Refer to purifier technical manual and PMS for maintenance instructions.

542-6.5.8 PURIFIER TROUBLESHOOTING. If poor operation, rough running, or unusual noises from the purifier are detected, check for probable causes from the following lists.

542-6.5.8.1 Poor operation of the purifier may be caused by:

- a. Speed too low
- b. Improper bowl assembly
- c. Bowl not clean
- d. Wrong size discharge ring
- e. Leaky bowl ring or discharge ring
- f. Obstruction in tubular shaft or regulating tube
- g. No water seal
- h. Wrong bowl height
- i. Improper inlet or discharge pressure
- j. Improper disk compression

542-6.5.8.2 Rough running or noise may be due to:

- a. Improper oil level
- b. Damaged or worn running parts
- c. Bowl out of balance
- d. Bowl not properly seated on spindle
- e. Improper motor/purifier alignment
- f. Wrong bowl height
- g. Wrong spindle height

542-6.6 TANK LEVEL INDICATING SYSTEMS

542-6.6.1 TYPES. There are three basic types of remote-reading, tank liquid level indicating systems used for shipboard installations: the static head type, the electric type (MIL-L-23886), and the sounding tube pulse radar type. Information on tank level indicators is available in **NSTM Chapter 504, Pressure, Temperature, and Other Mechanical and Electromechanical Measurement Instruments**, and NAVSHIPS drawing 810-1385847.

- a. There are three types of static head systems:
 - 1 Type I are pneumatic systems formerly used for all JP-5 tanks, but are now typically replaced by the magnetic float electric type.
 - 2 Type II are water-filled systems formerly used for gasoline tanks, but discontinued due to their complexity and many operational difficulties.
 - 3 Type III are differential pressure systems per NAVSHIPS drawing 810-1385847, Type III, Class A. The Type III may be found on older ships for gasoline tanks and cofferdams.
- b. Electric systems, MIL-L-23886, are usually of the magnetic float (MF) type. MF electric level indicators have been used in replacing pneumatic systems on older ships. Use of the MF electric level indicating systems assists in the prevention of oil spills in fuel tanks that overflow directly overboard.
- c. Sounding tube pulse radar systems utilize a radar unit affixed to the top of a tank's sounding tube. Sounding tube pulse radar units are used to replace MF electric type level indicators in order to alleviate the necessity of entering fuel tanks for maintenance purposes. Dependent upon the sounding tube configuration, installation of air escape vent tubing may be required to insure the fuel level in the sounding tube is commensurate with the level of fuel in the tank.

542-6.6.2 DESCRIPTIONS OF STATIC HEAD TANK LEVEL INDICATORS. Type I, Type II, and Type III static head indicating systems have all been used for shipboard installations.

542-6.6.2.1 Type I indicators employ mercury or other liquids in a U-tube to indicate the level of liquid in the tank. The front side of the U-tube connects to an air chamber above the tanks, and the back side of the U-tube connects to an air bell near the bottom of the tank. When the tank is empty, atmospheric pressure will load each side of the U-tube and the indicator will read empty. When the tank is full, static pressure from the liquid will load the air bell near the bottom of the tank, while the air chamber above the tank will load the other side of the U-tube with atmospheric pressure and the indicator will show full. Between empty and full, the pressure difference is calibrated to read gallons directly on the scale of the indicator.

542-6.6.2.2 The Type II system is actuated by the relationship of hydrostatic pressure between two in-tank reservoirs, one at the top of the storage tank and one very near the bottom of the tank. The reservoirs are connected to the level indicating gage through connecting lines that maintain a seawater seal to prevent the entry of the fuel into the lines. The differential pressure developed between the reservoirs is thus transmitted to the gage. When the tank is full of seawater, no differential exists and the gage reads empty. As the tank is filled with fuel, a pressure is developed between the reservoirs because the water above the lower reservoir is being replaced by fuel. The pressure differential is transmitted to the gage through the water-filled connecting tubes.

542-6.6.2.3 Type III indicators consist of tank upper and lower sensing heads having a diaphragm or bellows sealed sensing head that connects to differential pressure indicators through liquid filled tubing. The differential pressure indicator is calibrated in gallons of liquid.

542-6.6.3 DESCRIPTION OF MF ELECTRICAL TYPE SYSTEM. MF systems are installed on ships and have been used to replace outdated static head gages. The electric tanks level indicating system is fully detailed in NAVSEA 0965-LP-060-1010, **GEMS Tank Level Indicating (TLI) System** .

542-6.6.3.1 This indicator consists of a magnetic float, a transmitter or sensor, and primary and secondary receivers. The transmitter stem consists of a rod or series of rods mounted vertically within the tank. The magnetic float is cylindrical with a hole in the center. The magnetic float operates reed tap switches in the rod as it moves up and down on the surface of the fluid. The electrical resistance of the transmitter changes according to the location of the switches that are closed, and this provides an indication of tank level. The float movement is transmitted to a receiver (dial indicator), which is calibrated in gallons of liquid.

542-6.6.3.2 MF liquid level indicators in tanks overflowing directly overboard have integral high-level alarms to warn of an impending overboard fuel discharge. The alarms are set to sound at a point between 95 and 98 percent of tank capacity. The selected alarm point is based on providing an approximate 2-minute warning that the tank has been overfilled and an overboard fuel discharge will occur unless tank filling is immediately secured. Alarm set points are above 95 percent tank capacity to prevent their activation during routine tank filling.

542-6.6.4 Description of Sounding Tube Pulse Radar Systems. The sounding tube pulse radar system consists of a radar unit installed atop a fuel tank sounding tube. The radar unit transmits signals down the sounding tube, where the signal reflects off of the top of the liquid level and returns to a receiver integral with the radar unit. The radar unit software uses the time required for the signal to travel to the liquid level surface and return to calculate the level in the tank, in comparison to sounding tables programmed into the unit. The software then equates the sounding level to gallons and provides tank level data to an output source, such as a meter, digital display or computer.

542-6.6.5 TLI OPERATION. Before operating any tank level indicating system, refer to the instruction plate or the manufacturer's instruction book.

542-6.6.6 TLI MAINTENANCE. Refer to manufacturer's technical manual for maintenance.

542-6.7 MOGAS SYSTEM PRESSURE VALVE AND VENTURI

542-6.7.1 On LHA and some LPD ships, the gasoline riser is fitted with a pilot-operated, pressure-regulating valve (MIL-V-15358) and venturi combination, located in the gasoline pumproom. It controls topside pressure at the inlet to the fueling stations. (See [Figure 542-6-15](#)).

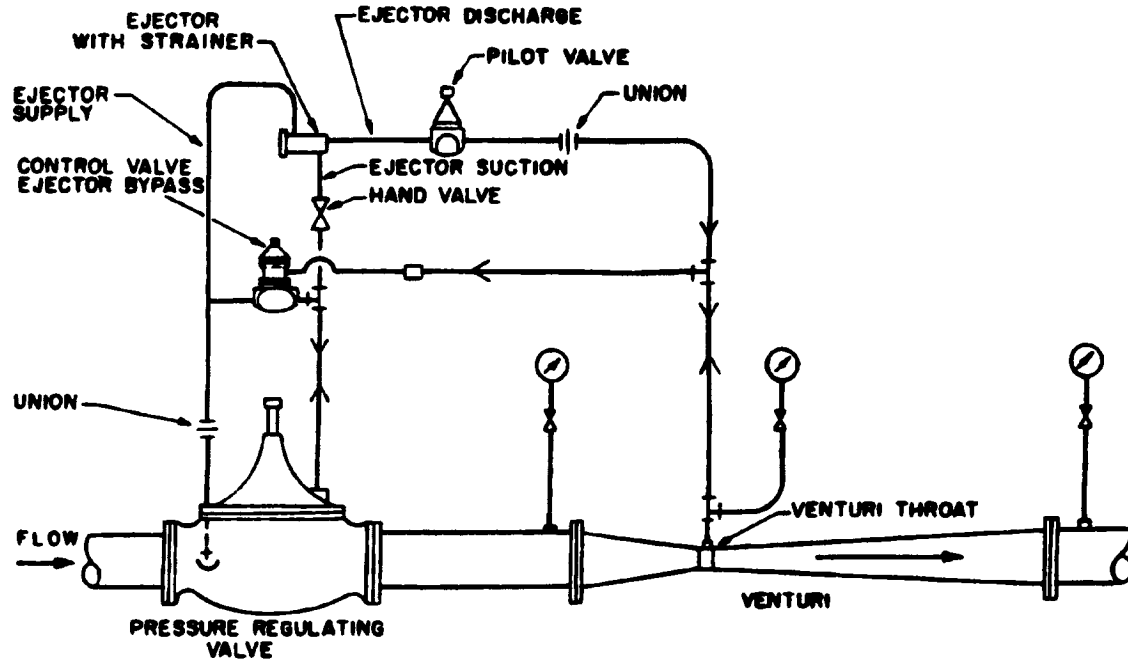

Figure 542-6-15. Pressure Regulating System Schematic

542-6.7.2 The pilot-operated regulating valve is activated by the pressure at the throat of the venturi to maintain a constant throat pressure equal to the sum of the static head (from the venturi to the point of connection between the riser and the distribution main) plus the pressure required at this connection point to maintain the needed pressure at the nozzle discharge of the most remote fueling station under maximum flow conditions.

542-6.7.3 The venturi is designed so that the difference between the pressure at the inlet and the pressure at the throat equals the friction loss from the venturi to the main/riser connection point under all flow conditions. The length of the approach to the venturi equals a minimum of six times the diameter of straight pipe.

542-6.7.4 A recirculating line containing an orifice is installed on the downstream side of the venturi. The rate of venturi recirculation is sufficient to permit satisfactory operation of the regulating valve and venturi combination under no-flow conditions. The recirculating line terminates at the midpoint of the drawoff tank. Venturi and gasoline pump recirculation lines may be combined into a common return line to the midpoint of the drawoff tank. A warning plate is installed at the pump stating: Venturi and pump recirculation line valves must be open before starting pump.

542-6.8 AUTOMATIC CLA-VAL FUEL-DEFUEL VALVE

542-6.8.1 On CV/CVN, LHA, LHD, LPD type ships, each hose reel at the aircraft fueling stations contains a solenoid-operated fueling-defueling (CLA-VAL) valve. MOGAS vehicle fueling stations on some LPD ships are also of the CLA-VAL type. When the solenoid is energized (see [Figure 542-6-16](#)), the valve is in the fueling position until the solenoid is de-energized, which automatically returns it to the defueling position (see [Figure 542-6-17](#)). The solenoid is energized from a low voltage control circuit that permits the flow of current to the solenoid as long as the low voltage circuit through the fueling hose to the ground is complete.

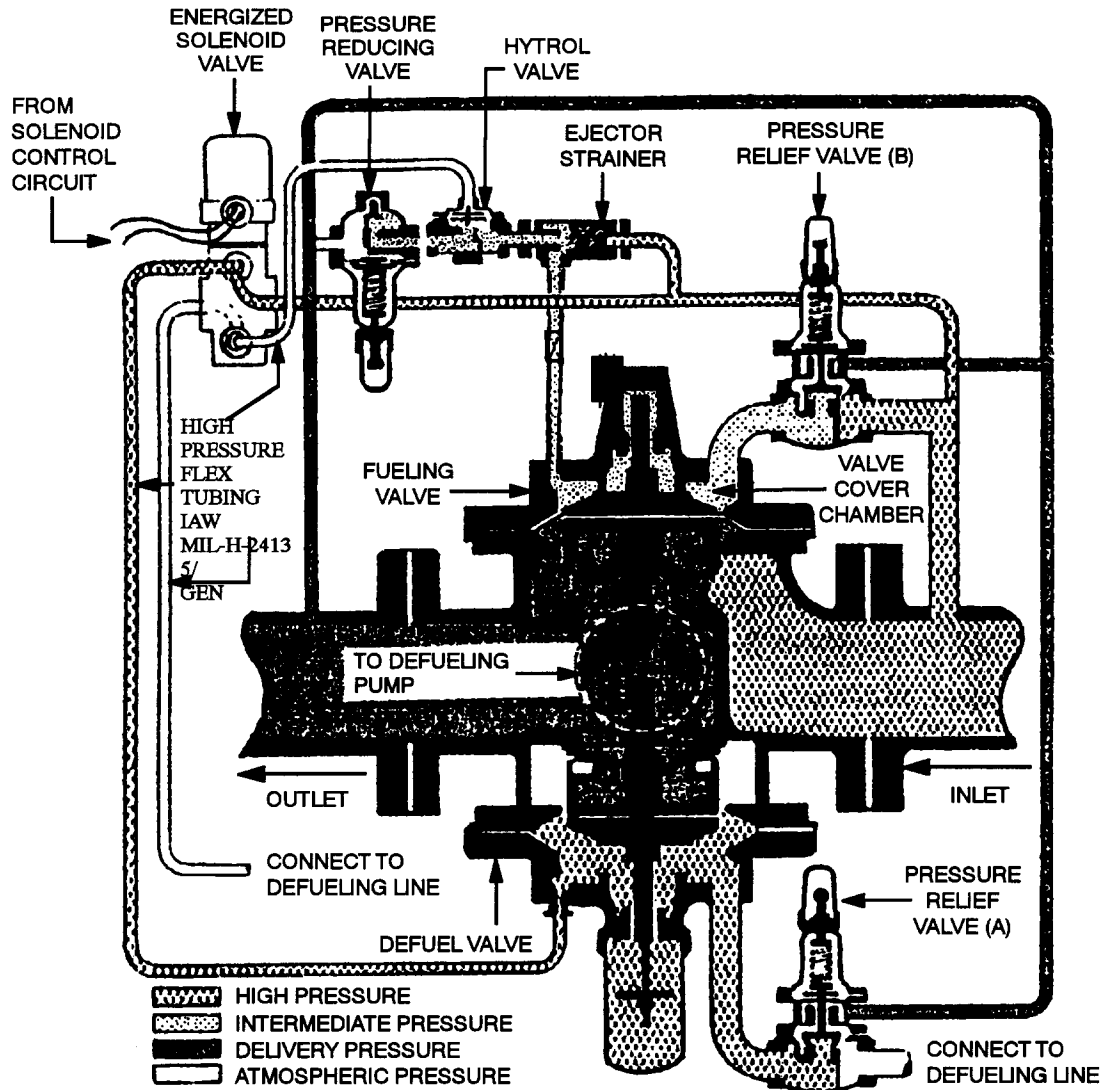

Figure 542-6-16. CLA-VAL Fuel-Defuel Valve (Fueling Mode)

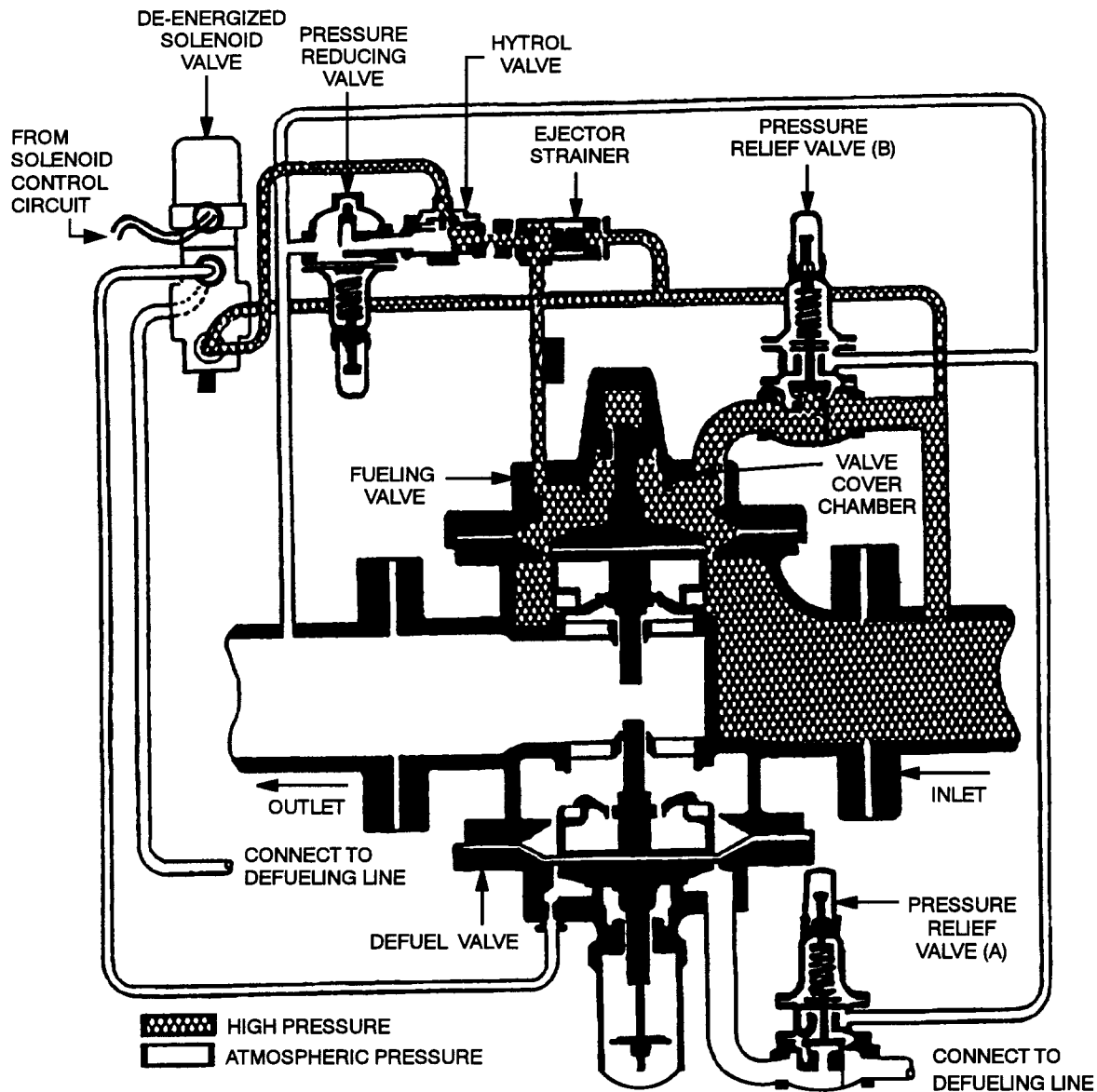

Figure 542-6-17. CLA-VAL Fuel-Defuel Valve (Defueling Mode)

542-6.8.2 A switch on the quick-disconnect coupling (QDC) provides the operator control over the fueling and defueling operations. An interruption in the electrical circuit or break in the electrical ground connection to the aircraft (or vehicle) will automatically return the valve to the defueling position. A magnetic amplifier (or solid state control), provided for each fuel-defuel valve, employs a small direct current to control the large alternating current. Typically, power supplied for the defuel pump (440 VAC) is reduced (to 110 VAC) via a transformer. The control circuit is limited to a current of such low magnitude that circuit interruption cannot ignite vapors. A master control switch or pushbutton is provided at each station to start or stop the defueling pump, which provides power to energize the solenoid-operated valve.

542-6.9 AIR ELIMINATOR VALVE

542-6.9.1 On aviation ships where pump suction can be flooded by gravity, an air eliminator valve functionally similar to the priming valve is used. The float-operated air eliminator valve permits the passage of air into a vent line to the purifier drain tank.

542-6.10 MOGAS SYSTEM EDUCTORS

542-6.10.1 PORTABLE EDUCTORS. Portable eductors are used to provide drainage for MOGAS pumphooms, to drain seawater flushing lines before rotating the spectacle flanges, and to remove condensate from piping during steaming out. When not in use, they are stored on a bulkhead in the MOGAS pumphoom.

542-6.10.2 FIXED EDUCTORS. Fixed eductors are used to drain accumulated water or fuel from the cofferdams surrounding the MOGAS storage tanks. Gages indicate the presence of liquid in the cofferdams. Each fixed eductor is connected to a seawater supply line and to a discharge line. These lines lead to hose valves, which are protected in a watertight box on the pumphoom deck. The suction end of the eductor is connected to suction piping extending around the inside of the cofferdams.

542-6.10.3 EDUCTOR OPERATION. Operation of MOGAS eductors is covered in paragraph [542-3.6.7](#).

542-6.10.4 EDUCTOR MAINTENANCE. Large fixed eductors are provided with an inspection plate that can be removed without disturbing the connecting piping, to permit inspection of the interior or replacement of the nozzle.

NOTE

Fixed eductors and associated piping and valves up to the manifolds are the responsibility of the ships engineering department. This includes preventive and corrective maintenance.

542-6.11 CENTRAL CONTROL AND MONITORING OF JP-5 SYSTEMS

542-6.11.1 GENERAL INFORMATION. A central control and remote monitoring system is installed aboard CVN-68 Class ships, which enables pump room personnel to operate and supervise the system from one central location. The CVN-68 Class ships have a far greater number of JP-5 storage tanks and, consequently, a higher storage capacity than CVN-65 and CVs. In the event of a malfunction or casualty to the control system, the system can be manually controlled. The remote control system reduces the number of men required in the affected spaces, since manual operation is only required to open and close a limited number of valves and in abnormal conditions. CVN-68 Class ships are equipped with a computer based control console. Consult the ship Ship's Information Book (SIB) for a detailed description of the console.

542-6.11.2 CONSOLE CONTROLS AND INDICATORS. The computer based control console is equipped with system diagrams showing the various valves, pumps, and other components that are operated and monitored from the control console. The system diagram shows the system piping (possibly, color-coded) and system components in their relative locations. Various compartments and frame spacing may be found on the console to indicate the general location of valves and components. Each control console contains the following controls and indicators:

- a. Liquid level indicators for JP-5 storage, JP-5 overflow, JP-5 service, JP-5 aircraft defueling, and contaminated JP-5 settling tanks. The indicators on the computer-based console are icons, which reflect the liquid level. Selection of a particular tank, via clicking on the icon, can show the tank contents in greater, larger detail.
- b. On the computer-based console, the icon will turn red upon activation of the high level alarm.

- c. The computer-based console uses color contrasting to indicated fuel and seawater.
- d. Controls for starting and stopping the JP-5 service pumps.
- e. On the computer-based console, the valve icon rotates to indicate a closed position or open position (in direction of the flow path).
- f. The computer-based console utilizes a change in the pump/purifier icon to convey its operation. Some versions of the computer-based console may include all pumps.
- g. Audible and visible overflow alarms to warn that any tank having an independent overboard overflow has reached the 95 to 98-percent full level.
- h. Changes in the tank icons on the computer-based console come on successively when seawater in the tanks reaches the 6-inch, 2-feet, 4-feet, and 6-feet levels.
- i. Controls for positioning electric motor-operated valves of the JP-5 transfer, service, and stripping systems, and the draining and ballasting system.
- j. Override switches that de-energize the circuit for closing the cutout valves when the tank reaches operating capacity. This allows complete tank filling when desired. Each switch controls as specific zone.
- k. The computer-based console segregates systems between differing screens for JP-5 stripping, transfer and service systems. Color-coding may be observed.
- l. The console rooms are equipped with sound-powered and J-dial phones.

542-6.11.3 JP-5 SYSTEM VALVES. Control and monitoring of JP-5 system valves are briefly outlined below:

- a. Service tank suction and recirculation valves. Remote control and position indication for the tank suction valves is provided at the control console. Each tank recirculation valve opens and closes simultaneously with the suction valve.
- b. Tank transfer manifold and service tank fill manifold valves. Remote control and position indication for these valves is provided at the console. The manifold valve closes automatically upon a signal from the tank high-level indicator. A high-level detector override switch permits filling the tank to 100 percent or draining it.
- c. Storage and service tank stripping manifold valves. Remote control and position indication are provided for some valves, and position indication only for other valves at the control console.
- d. Manually operated valves are monitored from the consoles and are equipped with limit switches that actuate OPEN and CLOSED indicator lights on the console.

542-6.12 Aircraft-to-Aircraft Transfer Cart.

The Aircraft-to-Aircraft Transfer Cart (commonly referred to as the "transfer cart") was designed in support of handling low flashpoint fuels in aircraft. The intent of the transfer cart is to draw low-flashpoint fuel from one aircraft and deliver it to another aircraft readying for flight operations in order to burn the low flashpoint fuel. The transfer cart consists of an air driven pump, piping, valves, a filter cartridge, sight glass, two hose reels (each equipped with 1-1/2" non-collapsible, MIL-PRF-370 hose), D-1 nozzles and air hoses. NAVAIR drawing PE1174-0 provides information for the construction of the transfer cart. Allowance Equipage List (AEL) 2-150004040 and Allowance Parts List (APL) 99A000062 apply. Refer to in NAVAIR 00-80T-109, **Aircraft Refueling NATOPS Manual** , for operating procedures of the transfer cart.

542-6.13 Portable Defuel Cart.

The portable defuel cart (commonly referred to as the "defuel cart") is designed to remove fuel from an aircraft in an emergency. The defuel cart consists of an air driven pump, air hose(s), a hose reel, MIL-PRF-370 hose(s), and nozzle(s). Hose end fittings may be required to support a hose installation on the discharge side of the air driven pump. The original intent of the defuel cart was to direct the removed aircraft fuel, via the air driven pump discharge, overboard. If the fuel is suitable for defuel back into the shipboard aviation fuel system (i.e. the fuel is proven to be JP-5 through shipboard laboratory testing), the discharge of the defuel cart can be aligned to the nearest aviation fuel system fueling station flushing adapter. If the fuel is to be directed overboard, consult **NSTM 593, Pollution Control** , for guidance.

SECTION 7
FUEL QUALITY MANAGEMENT

542-7.1 INTRODUCTION

542-7.1.1 This section is devoted primarily to fuel quality management of JP-5 Fuel systems for servicing aircraft. Fuel quality requirements are more critical and extensive for JP-5 aircraft fuel than for MOGAS fuel. Sampling requirements for MOGAS fuel are included in [Table 542-7-1](#).

Table 542-7-1. FUEL SAMPLING REQUIREMENTS

Fuel	Location	Periodicity	Acceptability	Test
MOGAS	Sponson sample valve	At start of pumping and every 15 minutes thereafter	Clear and bright	Visual
MOGAS	Fueling station sample valve	At start of pumping and every 15 minutes thereafter	Clear and bright	Visual
MOGAS	Filter discharge	At start of pumping and every 15 minutes thereafter	Clear and bright	Visual
MOGAS	Stripping pump sample valve	Prior to offload		Corrosion (shore laboratory)
JP-5	Sponson sample valve	At start of pumping and every 15 minutes thereafter	Clear and bright (Note 1)	Visual
JP-5	Storage tank motor stripping pump discharge	During storage tank stripping	Clear and bright	Visual
JP-5	Purifier or transfer filter discharge	At startup and every 15 minutes when operating	Clear and bright	Visual (Note 2)
JP-5	Storage tank motor stripping pump discharge	(Note 3)	(Note 3)	Specific Gravity
JP-5	Filter sump	At filter startup and every 4 hours during operation	No solids	Visual
JP-5	Reclamation filter	At startup and every 15 minutes when operating	Clear and bright	Visual
JP-5	Service tank stripping pump discharge	All service tanks daily at sea, and prior to initial suction (monthly in port)	Clear and bright	Visual (Note 2)
JP-5	Service filter discharge	Daily before refueling and every 15 minutes thereafter, and when switching service tanks for each operating filter.	Clear and bright	Visual (Note 2)
JP-5	Aircraft fueling nozzle	(Note 4)	Clear and bright	Visual (Note 2)
JP-5	Low points of aircraft fuel cells	Before defueling	Clear and bright, 140° F (min) flashpoint	Visual and flash point
JP-5	Service filter discharge	Daily before refueling and each 4 hours of operation thereafter (draw sample during flow condition) for each operating filter	2.0 mg/L (max) sediment and 10 ppm (max) free water (refer to Note 2)	Sediment and water (Note 2)

Table 542-7-1. FUEL SAMPLING REQUIREMENTS - Continued

Fuel	Location	Periodicity	Acceptability	Test
JP-5	Aircraft fueling nozzle	(Note 5)	2.0 mg/L (max) sediment and 10 ppm (max) free water (refer to Note 2)	Sediment and water (Note 2)
JP-5	Purifier or transfer filter discharge	Beginning of evolution and every 4 hours of operation	2.0 mg/L (max) sediment and 10 ppm (max) free water (refer to Note 2)	Sediment and water (Note 2)
JP-5	Each service tank stripping pump discharge	All service tanks daily at sea (monthly in port) (Note 6)	2.0 mg/L (max) sediment, 10 ppm (max) free water, 0.03 percent vol. (min) FSII (Note 2)	Sediment, water, and FSII (Note 2)
JP-5	Service filter discharge and one nozzle per quadrant	Prior to extended deployment, or as ordered	2.0 mg/L (max) sediment and 140° F flash point, .03 percent vol. (min) FSII	Sediment, flash point, and FSII (shore laboratory)

Note 1. Pier side deliveries shall not contain JP-5 in excess of 8 mg/L of solids and shall be clear and bright with no visible water. Fleet oiler or barge deliveries shall not contain JP-5 in excess of 10 mg/L of solids and shall be clear and bright with no visible free water.

Note 2. Manual visual and laboratory samples are not required for the following areas where an in-line quality sensor (Autogrape) is installed: (a) the service pump stripping discharge, (b) purifier/transfer filter separator, (c) service filter separator or (d) aircraft fueling station where one in-line quality sensor serves one hose reel. Real-time fuel quality output at the specific location is displayed and recorded on the shipboard monitoring and control system. Manual visual and laboratory samples may be used as a back-up to the installed in-line quality sensor, where the situation dictates. Manual visual and laboratory samples are required where the in-line quality sensor is not installed. Visual samples, as prescribed by Note 4, are required where one in-line quality sensor serves two or more hose reels

Note 3. Sample and test storage tank motor stripping pump discharge for the specific gravity weekly (at sea), and after receiving new fuel. Results are to verify the correct JP-5 centrifugal purifier discharge ring size as found in the purifier technical manual chart for specific gravity versus discharge ring size.

Note 4. For CV/CVN, LHA, LHD, LPD: Upon leaving port (following stand down or repairs) each station hose and nozzle must be flushed to obtain a clear and bright sample. Sample must be drawn during a flow condition. On subsequent flying days, a random sample will be drawn from each quadrant. Any hose and nozzle not utilized within a 24-hour period must be flushed until an acceptable sample is obtained. For ships not noted above: The hose and nozzle utilized for refueling helicopters must be flushed and JP-5 quality ensured prior to each refueling. Sample must be drawn during a flow condition.

Note 5. On a daily basis during flight operations and under flow conditions, draw one sample from each hose during a 24-hour period for ship's fuel lab analysis. Also, sample as ordered (implies quality of fuel is suspect).

Note 6. During daily operations following a sediment, water and FSII test. Only a visual clear and bright sample is required each time service tanks are topped off.

542-7.1.2 Minute amounts of dirt and water in fuel can cause engine failures. Deliver only clean, dry fuel to aircraft. Minimum concentrations of fuel system icing inhibitor (FSII) are required in aviation fuels to prevent icing of the fuel system and to retard microbiological growth in storage and aircraft tanks. The methods of contamination detection and removal, determination of FSII levels, and maintenance of the system filtration equipment are of major importance. Early detection through testing can avoid catastrophe. Monitoring and maintenance of fuel quality takes disciplined effort.

542-7.1.3 Naval Surface Warfare Center Carderock Division Ships Systems Engineering Station (NSWCCD-SSES) shall be notified by message, with information copy to the Naval Sea Systems Command (NAVSEA) and

Naval Air Systems Command (NAVAIR), if the system consistently fails to deliver fuel of the required quality. Any action taken to correct the situation shall also be included in the message.

542-7.2 FUEL QUALITY

542-7.2.1 VISUAL CRITERIA. JP-5 acceptable to aircraft must be clear and bright, and contain no free water. The terms clear and bright are independent of natural color of the fuel. Jet fuel is not dyed and may be any color from water-white to amber. Clear means the absence of any cloud, emulsion, readily visible particulate matter, or free water. Bright refers to the shiny appearance of clean dry fuel. A cloud, haze, specks of particulate matter, or free water indicates unsuitable fuel and points to a breakdown in fuel handling equipment or procedures. When JP-5 samples are designated for visual testing, refer to the free water visual test procedures in paragraph 542-5.3.3, test f.

542-7.2.2 SOLIDS CONTAMINATION. Solid contaminants can be held well below a level of 1 milligram per liter in a properly functioning fuel system. If solid contaminants in fuel at aircraft fueling points exceed 1 milligram per liter when measured by the contaminated fuel detector, an in-line fuel quality sensor, or by laboratory analysis, investigative and corrective actions are required. If solid contaminants exceed 2 mg/L, stop delivery of fuel to aircraft until corrective action has been taken.

542-7.2.3 FREE WATER CONTAMINATION. Free water in fuel can ruin aircraft fuel systems. It can cause filter or fuel control icing, fuel quantity probe fouling, and corrosion of fuel system components. It is also an item essential for microbiological growth. The maximum allowable limit of free water in fuel at aircraft fueling points is 10 parts per million when tested by the free water detector or in-line fuel quality sensor. For ships not equipped with an in-line fuel quality sensor, if the level of water in fuel at an aircraft fueling point exceeds 10 parts per million, take a second sample immediately. If the second sample confirms that the free water exceeds 10 parts per million, stop fueling until the problem is corrected. For ships equipped with an in-line fuel quality sensor, the real-time fuel quality results are averaged over a period of time. Therefore, if an alert/alarm condition occurs indicating exceeding 10 parts per million free water, then take immediate actions to identify and correct the problem.

542-7.2.4 FUEL SYSTEM ICING INHIBITOR. Certain aircraft require a minimum concentration of FSII in their fuel in order to prevent icing of the fuel system. Ice crystals will collect on screens and filters, quickly blocking them, and can cause fuel system valves to stick or malfunction. Using fuel without sufficient FSII can result in possible loss of an aircraft. Another primary function of FSII is to control microbiological growth in storage and aircraft tanks.

542-7.2.4.1 Di-ethylene-glycol-monomethyl-ether (DiEGME) is currently the only approved FSII additive for use in JP-5 because of its high flash point. Shipboard injection is not approved, because FSII materials are considered to be dangerous before they are added to fuel; however, they are safe once blended into the fuel.

542-7.2.4.2 FSII concentrations in fuel can be easily determined using the B/2 anti-icing additive test kit. If FSII content is less than 0.03 percent by volume, the appropriate squadron Commanding Officer (CO) shall be notified immediately. The applicable NATOPS Manual provides guidance to the squadron CO for such situations.

WARNING

JP-4 will flash at room temperature and well below. Safety glasses shall be used when testing any aircraft fuel.

542-7.2.5 FLASH POINT. JP-4 and JP-8 are jet fuels used by the United States Air Force and Army. Jet A-1 and Jet A fuels are used commercially. These other jet fuels all have flash points significantly lower than the minimum 140° F of JP-5, and would dangerously lower the flash point of JP-5 if defueled into the ship's JP-5 system, or drained into any other shipboard system, such as an oily waste system. Navy and Marine Corps aircraft are sometimes fueled at land-based stations or through in-flight tanking with these low-flash point fuels. A flash point test, using a closed-cup or NAVIFLASH flash point tester, shall be conducted on fuel extracted from aircraft low-point drains before defueling any aircraft. Aircraft with fuel having a flash point less than 140° F shall not be defueled into ship's JP-5 system, or drained into any other shipboard system, such as an oily waste system. Use of the aircraft-to-aircraft transfer cart is recommended, if installed, to handle low flash point fuels. Additional requirements for handling lower flash point fuels are covered in NAVAIR 00-80T-109, **Aircraft Refueling NATOPS Manual** .

542-7.2.6 ROLE OF FILTER SEPARATOR OR PURIFIERS. To ensure that high-quality fuel is delivered to the aircraft, two independent stages of filtration are provided to remove solids and water contamination. JP-5 passes through a transfer filter separator or centrifugal purifier during transfer from storage tanks to service tanks. Clean JP-5 then passes from the service tanks to aircraft through a service filter separator.

542-7.3 SAMPLING

542-7.3.1 SAMPLE REQUIREMENTS. The minimum sampling requirements, to include sampling locations, acceptability criteria, and periodicities, are specified in [Table 542-7-1](#). Additional sampling assists in providing sound fuel quality management. Aircraft pressure fueling nozzles have a sampling port, where a sampling valve (GTP-423) and coupler (GTP 235-1/4 or GTP 235-3/8) can be inserted to obtain a sample at the closest point of the nozzle discharge. The governing Operational Sequencing System (OSS) or Planned Maintenance System (PMS) may provide additional information.

542-7.3.2 SAMPLES FOR FUEL LABS. Samples shall be submitted to an approved laboratory prior to a deployment or as ordered. To ensure that these samples are typical of fuel being delivered, they shall be taken at the service filter separator discharge and at one random aircraft, fueling nozzle from each quadrant. Routine samples shall be tested for solids contamination, flash point, and FSII in accordance with [Table 542-7-1](#). Special samples are submitted because of known or suspected fuel problems; mark and test accordingly. It is essential that the shortest possible time elapse between sampling and receipt of the laboratory analysis report. Sampling prior to a deployment, as well as possible emergency sampling, must utilize the quickest available transportation to fuel laboratory location. refer to [Table 542-7-2](#) for fuel testing laboratory addresses. Taking samples prior to entering port, while fuel system is in normal operating conditions, is a recommended management technique.

Table 542-7-2. FUEL TESTING LABORATORIES

Location	Laboratory Shipping Address	Lab Mailing Address
East Coast		
Norfolk, VA	Master Petroleum Laboratory Building W-388 Norfolk, VA 23512-5100	Director, Fuel Department Naval Supply Center Code 700
Jacksonville, FL	Director, Fuel Department Navy Supply Center Code 700 8808 Somers Road Jacksonville, FL 32218-2600	(Same as Shipping Address)
Searsport, ME	Director, Aerospace Fuels Laboratory Det 20, SA-ALC/SFTLB Trundy Rd, Bld 14 Searsport, ME 04974-0408	Det 20, SA-ALC/SFTLB P.O. Box 408 Searsport, ME 04974-0408
Dayton, OH	Director, Aerospace Fuels Laboratory Det 13, SA-ALC/SFTLA Area B Bldg 70 Wright-Patterson AFB OH 45433-6503	Det 13, SA-ALC/SFTLA Wright-Patterson Air Force Base Dayton, OH 45433-6503
Tampa, FL	Director, Aerospace Fuels Laboratory Det 21, SA-ALC/SFTLC Bldg 1121 MacDill Air Force Base, FL 33608-0051	Det 21, SA-ALC/SFTLC P.O. Box 6051 MacDill AFB, FL 33608-0051
West Coast		
San Diego, CA	Fleet and Industrial Supply Center Point Loma Subbase Bldg. 50 199 Rosecranes San Diego, CA 92106	Director, Fuel Department Naval Supply Center 937 North Harbor Dr. San Diego, CA 92132
Seattle, WA	Naval Supply Center 7501 Beach Drive Port Orchard, WA 98366	Director, Fuel Department Naval Supply Center Code 700 P.O. Box 8 Manchester, WA 98353-0008
Mukilteo, WA	Director, Aerospace Fuels Laboratory Det 35, SA-ALC/SFTLD Ten Park Avenue C, Bldg 1 Mukilteo, WA 98275-0046	Det 35, SA-ALC/SFTLD Ten Park Avenue C, Bldg 1 Mukilteo, WA 98275-0046
NOTE		
NSC Pearl Harbor facilities should be used by units in the Central Pacific.		
Pacific		
Pearl Harbor, HI	Director, Fuel Department Naval Supply Center Code 700 Pearl Harbor, HI 96860	Director, Fuel Department Naval Supply Center Code 700 Box 300 Pearl Harbor, HI 96860-5300

Table 542-7-2. FUEL TESTING LABORATORIES - Continued

Location	Laboratory Shipping Address	Lab Mailing Address
Guam, Marianas Island	Director, Fuel Department U.S. Naval Supply Depot Code 700 PSC 455 Box 190 FPO AP 96540-1500	(Same as Shipping Address)
Yokosuka, Japan	U.S. Navy Fuel Depot Yokosuka	(Same as Shipping Address)

542-7.3.3 SAMPLE CONTAINERS. Use glass containers (1-quart size minimum) with nonmetallic caps. The inner cap seal shall not contain wax, paraffin, corrosive metal, or other material likely to contaminate fuel. The supply system can provide aviation fuel sample and shipping containers that conform to MIL-K-23714 and meet all requirements for shipment of aviation fuels by military and commercial transportation (refer to [Table 542-7-3](#)).

Table 542-7-3. STOCK NUMBERS FOR FUEL SAMPLING KITS

Fuel Sampling Kits	National Stock Number
Fuel sampling kit (complete)	8115-00-719-4111
Top and bottom cushioning (inner pack)	8115-00-719-4825
Replacement kit (four tags, four 32-oz. glass bottles)	8115-00-717-8572

542-7.3.3.1 Unsuitable containers and foreign substances cause false or misleading laboratory message reports that could interrupt fueling from a satisfactory system. Thoroughly clean, dry, and inspect containers before use, in accordance with the following procedure:

1. Wash the containers with soap and freshwater.
2. Rinse the containers thoroughly with freshwater.
3. Allow the containers to dry in an inverted position. Use the washer/dryer where installed.
4. When dry, cap the container. (All sample containers must be absolutely clean and free of water, dirt, and lint.) Store the clean sample bottles until ready for use.

542-7.3.3.2 Before sampling, rinse and flush the clean container three times with the fuel being sampled, then fill, leaving about ½-inch expansion space. Samples shall be capped promptly, protected from light, and shipped as soon as possible.

542-7.3.4 SAMPLE LABEL. Mark glass sample container to include all items listed below:

- a. Heading: Aviation Fuel Sample - Routine or Special Identification of ship submitting sample (name and hull number).
- b. Fueling station number or filter separator sampled.
- c. Type of fuel.
- d. Julian date sample is drawn.
- e. Name of person drawing sample.

- f. On special samples, outline suspected problems and symptoms.
- g. Laboratory Instructions: Notify ship by message if sediment contamination exceeds 2.0 mg/L, if flash point is below 136° F (57.8° C), or if FSII is less than 0.03 percent. Message shall include data from c, d, and e, as well as test results. A follow-up routine report of test results for all samples submitted is requested.
- h. Resamples of reported contamination shall also include the marking: **Resample, request immediate analysis and message report.**

542-7.3.5 AVIATION FUEL SAMPLE LOG. Maintain a fuel sample log including sequential listing of samples submitted for test, and results of the test as reported by the testing laboratory. Include the following information in the aviation fuel sample log:

- a. Heading: Aviation Fuel Sample -- Sediment, Flash point, and FSII.
- b. Identification of ship submitting sample (name and hull number).
- c. Fueling station number or filter separator sampled.
- d. Type of fuel.
- e. Date sample is drawn.
- f. Name of person drawing sample. Use this log in a continuing shipboard quality assurance program to document quality assurance efforts.

542-7.4 SHIPBOARD FUEL TESTING

542-7.4.1 APPLICATION OF FUEL TEST APPARATUS. Shipboard tests are conducted to insure the fuel quality being delivered to the aircraft. Equipment utilized to accomplish these tests include a contaminated fuel detector (or combined contaminated fuel detector) for solids contamination, a free water detector, an anti-icing additive refractometer for FSII concentrations, and a closed-cup tester (or NAVIFLASH unit) for flash point.

542-7.4.2 CONTAMINATED FUEL DETECTOR. The contaminated fuel detector (CFD), MIL-D- 22612, Type II, or combined contaminated fuel detector (CCFD) (NSN 6640-01-013-5279) are portable field units that measure the solids contamination in aviation turbine fuels. These instruments have a range of 0-10 mg/L of solids, and are designed for both gasoline and aviation turbine fuels.

542-7.4.2.1 Principles of Operation. The CFD/CCFDs operate as follows:

1. A sample of fuel is obtained in the bottle provided.
2. This sample is filtered through two membrane filters used in series. The solid contaminants will be collected on the top filter.
3. A light is shined through each filter, and a meter measures the decrease in transparency of the filters due to the trapped solids. Use of two filters minimizes or eliminates errors due to variations in color of different fuels.
4. A calibration chart is provided to convert the meter readings to contamination levels in mg/L.

NOTE

Extensive field tests have demonstrated that the calibration curve furnished with this unit is valid for the majority of fuel samples, but there are occasional samples that do not fit the normal pattern.

542-7.4.2.2 CFD/CCFD Typical Operating Instructions. The following instructions are typical for various CFD/CCFDs in the fleet. Refer to the operation and maintenance manual provided with each unit for specific guidance. Instructions are provided to first filter the sample, and then to measure the light transmission through the filters.

542-7.4.2.2.1 Filter the sample as follows:

1. Make sure that the receiving tank in the CFD/CCFD is empty. If necessary, drain the tank by turning the drain cock handle and allowing the fuel to drain through the Tygon tubing provided.
2. Close the drain cock.
3. Disassemble the filter holder and bottle receiver assembly (located in the lid) into its two components by turning the center locking ring counterclockwise and pulling the two sections apart. The section with the rubber stopper is the filter holder. Insert it into the opening in the receiving tank.
4. Place two new 0.65-micron cellulose membrane filters in series in the filter holder. Reassemble the filter holder and bottle receiver assembly by placing the bottle receiver component on top of the filter holder component and turning the locking ring clockwise. Be careful to rotate the ring only, to avoid tearing filters.
5. Remove the filter holder and bottle receiver assembly from the receiving tank and place the bottle receiver end over the top of the 32-ounce polyethylene bottle, filled to the 800 mL mark with fuel. Insert all of the threaded portion of the bottle top into the bottle receiver.
6. Insert the ground wire attached to the filter holder and bottle receiver assembly into the jack provided for it adjacent to the drain area. Turn on the pump switch.
7. Pick up the entire assembly (filter, holder, bottle receiver, and fuel sample bottle) as a unit; invert, and then insert filter holder end into the receiving tank. After all the fuel has drained from the bottle, remove the bottle. After all the fuel has passed through the filters, stop pump.
8. Drain the fuel from the tank through the Tygon tubing.

542-7.4.2.2.2 Measure the light transmission as follows:

1. Turn on the light switch during filter cycle to warm unit.
2. Be sure the unit has warmed up for 2 or 3 minutes.
3. With no filter in the receptacle, align the photocell into measuring position.
4. Using the rheostat knob, adjust the milliammeter until a reading of 0.6 is obtained.
5. Using forceps, pick up the contaminated top filter. Wet entire filter with clean JP-5 From the 16-ounce polyethylene bottle by making a puddle of JP-5 on the clean working surface and laying the filter in it.
6. Using forceps, place the contaminated filter in the receptacle provided.
7. Align the photocell back into measuring position.

8. Record the reading of the milliammeter.
9. Remove the filter.
10. Repeat step 5 through step 9 using the clean bottom filter.
11. Subtract the contaminated filter reading from the clean filter reading.
12. From the calibration curve, find corresponding value of contamination in mg/L or milligrams per gallon.

NOTE

The calibration curve that comes with each contaminated fuel detector will indicate that the fuel tested either meets the minimum requirements or is unacceptable. Duplicate samples sent to the laboratory for gravimetric analysis will give a cross-check on the instrument.

13. If values above 1.0 mg/L are obtained, the contamination should be investigated. If values at or above 2.0 mg/L are obtained, the contamination value shall be reported. The procedure for additional testing using hexyl alcohol to remove the stain caused by a fuel additive has been discontinued. The additive responsible for the staining problem has been deleted from the JP-5 fuel specification (MIL-T-5624).

542-7.4.2.3 Use of the CFD/CCFD. Remember that this instrument will not replace the periodic laboratory analysis, only supplement it. While the unit is comparatively simple to use, it is a precision instrument and should be treated accordingly. It must be operated correctly to obtain accurate contamination values. For best results, its use may be restricted to the person responsible for quality control and inspection of aviation fuels for the activity. Use this unit for at least the following inspections:

- a. Daily monitoring of filtration equipment.
- b. Daily spot checks on the fuel at aircraft refueling nozzles.
- c. Daily checks on shipboard service and transfer filter separator or centrifugal purifiers.
- d. Discharge samples from tanker vessels (10 mg/L maximum allowable).
- e. Checks of any suspect fuel.
- f. Troubleshooting of equipment.

542-7.4.2.3.1 For valid results, use truly representative fuel samples and keep the whole operation free of contamination. Normally it is easier to bring the fuel sample to the instrument than the instrument to the fuel.

542-7.4.2.3.2 These detectors have been procured for all shore activities that operate aircraft and for all aviation ships. Complete details on the operation of the detector are contained in the manual supplied with each detector.

542-7.4.3 FREE WATER DETECTOR. The free water detector MIL-D-81227 (NSN 6640-00-999- 2786) is a simple, small unit for use in the field or the laboratory to provide quick and accurate measure of free water traces in aviation turbine fuels. It was designed for use with the contaminated fuel detector and will measure the free water content in gasoline or aviation turbine fuels. Perform the free water detector test as soon as possible following sampling. This test, conducted by the sampling activity, is the only free water determination now required, and is more accurate than can be obtained from a sample sent to a laboratory.

542-7.4.3.1 Principles of Operation. The free water detector operates as follows:

1. A sample of fuel to be tested is passed through a chemically treated filter pad placed in the filter holder of the free water detector. The chemical on the pad reacts to any free water in the fuel, producing a fluorescent pattern readily visible under the ultraviolet light in the view kit.
2. The amount of free water in the fuel sample is indicated by the intensity of fluorescence on the test pad. Visual comparison is made with a series of standards representing known quantities of water.

542-7.4.3.2 Free Water Detector Operating Instructions. Instructions are provided to first pass the fuel sample through a detector pad, and then to analyze the fluorescent intensity of the test pad.

542-7.4.3.2.1 Pass the sample through the detector pad as follows:

1. Mark the polyethylene bottle used with the contaminated fuel detector 3-1/4 inches from the bottom. A 500-mL sample will fill the bottle to this mark.
2. Fill the polyethylene sample bottle to that 500-mL mark with fuel to be tested.

CAUTION

Handle the detector pad with forceps only and use each pad one time only.

3. Open a free water detector envelope, and place the detector pad, orange side up, on the contaminated fuel detector filter base. Attach the bottle receiver to the filter base and plug in the ground wire jack.
4. Check to make certain that the receiving tank is empty and the drain valve is closed.
5. Shake the sample bottle containing the 500-mL fuel sample vigorously for approximately 30 seconds.
6. Immediately after shaking, turn the vacuum pump on, unscrew bottle cap, and place the bottle receiver and pad holder assembly firmly over the end of the bottle. Insert all of the threaded portion of the bottle top into the bottle receiver. Pick up the entire assembly (pad holder, bottle receiver, and fuel sample bottle) as a unit; invert, and then insert pad holder end into the receiving tank of the contaminated fuel detector. (This step must be accomplished quickly to keep any free water in suspension.)

542-7.4.3.2.2 Determine the quantity of free water by analyzing the intensity of detector pad fluorescence as follows:

1. After the 500-mL sample has passed through the detector pad, turn off the vacuum pump immediately, and remove the bottle and bottle receiver.

NOTE

Be sure to stop drawing air through the detector pad.

2. Remove the detector pad from the filter base using forceps and place it (orange side up) in the free water detector slide depression.
3. Light the ultraviolet bulb in the free water detector by holding the light switch in the ON position, and insert the slide containing the test pad.

4. Look through the view port of the box and compare the brightness of the fluorescence of the test pad with the brightness of the set of standards to determine the amount of free water. Free water content is indicated in parts per million (ppm) by the numbers located directly above the standards. Report results either as "No Free Water" or as actual free water content (estimated to the nearest ppm).
5. If the result is greater than 20 ppm, take a new sample one half the volume of the standard sample and double the resulting water content value. Drain fuel from the receiving tank of the contaminated fuel detector through the Tygon tubing.

542-7.4.4 **COMBINED CONTAMINATED FUEL DETECTOR.** The combined contaminated fuel detector (CCFD), MIL-D-22612, Type III (NSN 6640-01-013-5279) can test for both solids contaminants and free water. This instrument combines the capabilities of the contaminated fuel detector with those of the free water detector. Principles of operation and operating instructions for the CCFD are similar to those for the contaminated fuel detector (paragraph 542-7.4.2) and the free water detector (refer to paragraph 542-7.4.3).

542-7.4.5 **FSII TEST KIT.** The B/2 anti-icing additive refractometer and test kit (NSN 6630-01-165-7133) provides a simple and accurate means of determining the FSII content of aviation fuels.

542-7.4.5.1 **Principles of Operation.** A sample of fuel to be tested is placed in a separatory funnel along with a small quantity of tap water. After agitation, a few drops of the water layer are placed on the cell of the refractometer and a reading is taken directly from the appropriate scale.

542-7.4.5.2 **Operating Instructions.** Detailed operating instructions are provided with the test kit.

542-7.4.6 **FLASH POINT TEST PROCEDURES.** These test procedures are used with various manufacturer's testers, including both Pensky-Martens and NAVIFLASH. They allow for the determination of the fuel flash point according to ASTM D-93, **Standard Test Method for Flash Point by Pensky-Martens Closed Tester**. For both methods, fuel is heated in a closed cup at a specified rate until a flash is detected, either visibly or by sensing pressure build-up, signifying flash point. The Pensky-Martens method uses an open flame which is periodically dipped into the test chamber; the NAVIFLASH method uses an electric spark and pressure transducer.

NOTE

Investigative testing has shown that a discrepancy exists between JP-5 flashpoint results obtained via the NAVIFLASH and Pensky Marten Closed Cup (PMCC) test methods, in that JP-5 flashpoint results obtained via NAVIFLASH testing average 2 to 4 degrees F (1 to 2 degrees C) lower than those obtained for the same fuel via the PMCC test method. Accordingly, the PMCC test method shall be used as the referee test method to determine the acceptability, storage and usage of any JP-5 fuel exhibiting suspect NAVIFLASH flashpoint test results. When ships receive JP-5 pier side, ships observing JP-5 flashpoint test results below the 140 degrees F (60 degrees C) minimum via the NAVIFLASH test method shall have the fuel re-tested via the PMCC test method either onboard ship (where available) or by a local, approved fuel laboratory. Local, approved fuel laboratories include fuel testing laboratories listed in Table 542-7-2, or a DESC approved contract lab. Sample testing at a local DESC approved contract lab may be coordinated through DESC assistance. Where ships receive JP-5 while underway and shipboard NAVIFLASH testing shows a flashpoint below

the 140 degrees F (60 degrees C) minimum requirement, documentation from the supplying ship indicating the fuel load out quality reports meet the 140 degrees F (60 degrees C) flashpoint requirement shall suffice. Further testing by the receiving ship may be conducted by shipping samples to an approved laboratory for PMCC testing. In instances where a fuel flashpoint fails via the NAVIFLASH test method but passes via the PMCC test method, the PMCC test results shall be used to determine fuel acceptability.

542-7.4.6.1 Pensky-Martens Method.

542-7.4.6.1.1 The following equipment is required for this test:

NOTE

Initiatives are underway to identify, select, test and evaluate non-mercury thermometers. Upon engineering approval, an Advance Change Notice (ACN) will be issued to reflect updated supply information, such as that expressed in the following table.

ITEM	NSN
Flash Point Tester, 115V, 50/60 cycle ac	6630-00-530-0987
Cover, with Operating Mechanism	6630-00-394-7744
Electric Stirrer, 50/60 cycle	6640-00-531-5022
Thermometer, 20-230° F, ASTM 9F	6685-00-242-2183
Dry Cleaning and Degreasing Solvent, FED-SPEC-P-D-680, Type II, 5-gal can	6850-00-274-5421

542-7.4.6.1.2 The following procedures shall be used for the Pensky-Martens Method:

1. Thoroughly clean and dry all parts of the cup and its accessories before starting the test. If P-D-680 solvent was used to clean the apparatus, be sure that all solvent is removed before adding the sample. If necessary, filter the fuel through filter paper to remove all water before testing.
2. Fill the cup with the sample to the line etched in the side of the cup. Place the lid on the cup and set the cup in the oven. Make sure that the locking device is properly engaged.
3. Insert the thermometer to the proper depth, and light the test flame. Adjust gas flow so that the flame is 5/32 inch (4 mm) in diameter. Apply heat at such a rate that the temperature of the sample rises approximately 10° F (6° C) per minute. The stirrer should be at a rate of 90 to 120 rpm.
4. Apply the test flame when the temperature approaches 30° F (17° C) below the expected flash point, and thereafter at every 2° F (1° C).

NOTE

The minimum flash point for F-76 and JP-5 Fuel is 140° F (60° C).

5. When applying the test flame, stand to the side of the test apparatus (well away from the test flame and shutter mechanism) and quickly lower the flame into the sample chamber. Allow the flame to remain in the chamber for approximately 1 second. The sample stirring mechanism should be disengaged when applying the test flame.

6. Record the flash point as the temperature at which a distinctive flash is visible in the test chamber. Do not confuse it with the bluish halo that sometimes surrounds the test flame immediately before the actual flash point.
7. Allow the unit to cool. Remove the cover apparatus, pour the sample residue into a suitable waste receptacle for later disposal, and clean the sample cup with FED-SPEC-P-D-680 Type II solvent. Allow all solvent to completely evaporate before testing next sample.

WARNING

To minimize fire hazard, ensure that the unit is secured and unplugged and the gas supply is properly secured upon completion of testing.

542-7.4.6.2 NAVIFLASH Method

542-7.4.6.2.1 The following equipment is required for this test:

ITEM	Temporary NSN	NSN
NAVIFLASH Test Kit, Complete	0099-LL-H41-1846	6625-01-472-6783
Sample Cup	6630-01-457-4088	0099-LL-H41-1855
Anti-Vibration Plate, Shock Protecting	0099-LL-H41-1847	4910-01-470-6031
Dust Protection Cover, Vinyl	0099-LL-H41-1848	5340-01-472-7841
Pipette, Metal, 1.0 mL, Red Identifier	0099-LL-H41-1849	6640-01-472-3855
Pipette Tips, 1.0 mL, Disposable 1000 Count	0099-LL-H41-1851	6640-01-457-4508
Calibration Kit, n-Dodecane, 60 - 3mL vials	0099-LL-H41-1854	6810-01-419-2677
Volumetric Flask	0099-LL-H41-1853	6640-01-473-0776
Pipette, 5.0 mL	0099-LL-H41-1850	6640-01-473-0760
Pipette Tips, 5.0 mL	0099-LL-H41-1852	6640-01-473-0772
Swabs, cotton	- - -	6515-00-303-8250

542-7.4.6.2.2 The following procedures shall be used for the NAVIFLASH Method:

1. Depress rear-mounted rocker ON/OFF switch, powering the NAVIFLASH.
2. Use up and down arrow keys to scroll to Shipboard Program Number 1 or 4, for Fuel Acceptance Test or Calibration Programs, respectively. Press TASK key to select.

NOTE

Both calibration and fuel acceptance operations are identical, except n-Dodecane fluid, vice fuel sample, is used for calibration. Accomplish calibration of each installed NAVIFLASH unit monthly.

3. LCD screen will display FUEL ACCEPTANCE - FLASH/NO FLASH, OVEN HEATING WAIT. During this period, the oven is heated to its programmed starting test temperature.
4. Shake sample bottle vigorously to mix contents prior to testing. Use the pipette assembly to transfer 1.0 mL of sample fluid to sample cup. Fluid level should rise to scribed line in interior of sample cup.

5. Once LCD screen displays FILL & INSERT CUP IN CHAMBER, insert sample cup into test chamber, securely seating it onto automatic elevator. Close external door. Press RUN key.
6. "MEASUREMENT IN PROGRESS" will then be displayed on screen.
7. Upon completion of test, flash point temperature, in degrees F, will be displayed on LCD screen, accompanied by GREEN/RED lights.
 - a If measured flash point is greater than or equal to 140° F, GREEN light will flash and screen will display ACCEPT FUEL message.
 - b If less than 140° F, RED light will flash, accompanied with audible alarm, and REJECT FUEL message will be displayed. Press STOP to silence alarm and acknowledge message.

NOTE

Flash point measurements shall be performed in duplicate using separate samples. Agreement should be within $\pm 5^\circ$ F.

8. Once STOP is pressed, oven is cooled down to the starting temperature automatically.

NOTE

Inspect oven chamber interior. To avoid contamination from previous measurements, gently use cotton swab to remove any residual fluid adhering to spark plug and thermocouple.

9. Empty sample cup of remaining fuel and thoroughly wipe cup reservoir.

NOTE

When subsequent testing involves changes in fuel types (F-76 and JP-5), run tester with sample cup dry to ensure any residual fluid is removed.

10. Refer to detailed Operating Instructions, supplied with test kit, for specifics regarding error messages.

CAUTION

If operational necessities dictate, the operating command may authorize use of fuel containing more than 2.0 mg/L of solids or 10 ppm of free water. Such command decisions will, however, adversely affect aircraft fuel system reliability, increase maintenance, and shorten the service life of aircraft fuel system components. The effects of contamination are cumulative.

542-7.4.7 In-Line Fuel Quality Sensor.

The in-line fuel quality sensor (also known as Autogrape) is a real-time instrument that detects free water and sediment in fuel. The sensor continuously emits a laser beam directed across the fuel stream. Contaminants in the fuel (water or sediment) scatter the laser beam light, and the angle and intensity of the scattered light correlates to the type and concentration of contaminants. The data is communicated to a display console, where the results are displayed in milligrams per liter (solids) and parts per million (water).

542-7.5 TEST RESULT ACTION

Take the following actions if any of the shipboard tests indicate fuel contamination or if a message from a fuel laboratory indicates contamination:

1. Stop delivery to aircraft of aviation fuel from the suspected segment of the ship's fueling system if possible. If continued fueling is mandated, use extreme caution in utilizing fuel from the suspected section. Use the visual sampling procedures and frequent testing by the CFD, CCFD, and free water detectors or conduct diligent observation of the in-line fuel quality sensor results indicating on the control console.
2. Resample suspected fueling nozzle and supplying filter separator output, and deliver samples to the nearest laboratory for immediate analysis. Request priority and a message report on resample.
3. Change the coalescer elements and defective separator elements in the service system filter separator concerned, if re-sampling confirms existence of unacceptable fuel contamination or free water.
 - a. If re-sampling at nozzle(s) indicates free water, ensure that condensation in distribution piping between filter separator output and fueling nozzle(s) has not occurred from failure to keep distribution piping full at all times.

NOTE

Air capable ships do not maintain charged service system piping; therefore, flush hose if nozzle samples indicate free water.

- b. If resampling at nozzle(s) indicates contamination in excess of 2.0 mg/L, conduct complete check of hose and service station pump servicing the affected nozzle(s). This check should include looking for deteriorated hoses, rusting or flaking of internal parts of the service station pump, and possible defueling of contaminated fuel into the system.
4. Resume delivery of the fuel from the suspected segment of the fuel system if resamples are reported containing no free water and sediment contamination less than 2.0 mg/L.

542-7.6 JP-5 TANK STRIPPING

542-7.6.1 STRIPPING SYSTEMS. JP-5 stripping systems are provided to strip settled contaminants from storage tanks and service tanks. For stripping system descriptions, refer to [Section 4](#). Tanks shall be stripped until visual samples from the stripping pump outlets are free from settled contamination and water.

NOTE

Stripping pump operators should be trained in sampling techniques to minimize JP-5 losses.

542-7.6.2 STORAGE TANK STRIPPING. Storage tanks shall be stripped:

- a. Before receiving JP-5
- b. Weekly, when underway
- c. Monthly, when in port.
- d. Before transfer to service system

542-7.6.3 SERVICE TANK STRIPPING. Periodic stripping of service tanks is imperative to ensure that water-contaminated fuel is not delivered to the aircraft. The tanks shall be stripped:

- a. At sea, daily, prior to flight operations (laboratory analysis required, refer to [Table 542-7-1](#)).
- b. Monthly, in port.

542-7.7 MAINTENANCE

If equipment is not covered by Planned Maintenance System (PMS), or if coverage is considered inadequate, submit requests for correction on OPNAV Form 4790/7.

APPENDIX A**TECHNICAL MANUAL DEFICIENCY/EVALUATION REPORT(TMDER)****NOTE**

Ships, training activities, supply points, depots, Naval Shipyards, and Supervisors of Shipbuilding are requested to arrange for the maximum practical use and evaluation of NAVSEA technical manuals. All errors, omissions, discrepancies, and suggestions for improvement to NAVSEA technical manuals shall be reported to the Commander, NAVSURFWARCENDIV, 4363 Missile Way, Port Hueneme, CA 93043-4307 in NAVSEA/SPAWAR Technical Manual Deficiency/Evaluation Report (TMDER), NAVSEA Form 4160/1. To facilitate such reporting, print, complete, and mail NAVSEA Form 4160/1 below or submit TMDERS at web site <https://nsdsa2.phdnswc.navy.mil/tmder/tmder-generate.asp?lvl=1> . All feedback comments shall be thoroughly investigated and originators will be advised of action resulting therefrom.

NAVSEA/SPAWAR TECHNICAL MANUAL DEFICIENCY/EVALUATION REPORT (TMDER)

INSTRUCTIONS: Continue on 8 1/2" x 11" page if additional space is needed.

1. Use this report to indicate deficiencies, problems and recommendations relating to publications.
2. For CLASSIFIED TMDERs see OPNAVINST 5510H for mailing requirements.
3. For TMDERs that affect more than one publication submit a separate TMDER for each.
4. Submit TMDERs at web site <https://nsdsa2.phdnswc.navy.mil> or mail to: **COMMANDER, CODE 310 TMDER BLDG 1389, NAVSURFWARCENDIV NSDSA, 4363 MISSILE WAY, PORT HUENEME CA 93043-4307**

1. PUBLICATION NUMBER	2. VOL/PART	3. REV/DATE OR CHANGE	4. SYSTEM/EQUIPMENT ID
5. TITLE OF PUBLICATION			6. REPORT CONTROL NUMBER) (6 DIGIT uic-yy-ANY FOUR: XXXXXX-03-XXXX)

7. RECOMMEND CHANGES TO PUBLICATION

7a. Page #	7b. Para #	7c. RECOMMENDED CHANGES AND REASONS

8. ORIGINATOR'S NAME AND WORK CENTER	9. DATE	10. ORIGINATOR'S E-MAIL ADDRESS	11. TMMA of Manual
12. SHIP OR ACTIVITY Name and Address (Include UIC/CAGE/HULL)		13. Phone Numbers: Commercial () - - DSN - - FAX () - -	

Submit manual change requests preferably @ web site <https://nsdsa2.phdnswc.navy.mil>, or mail to: **COMMANDER, CODE 310 TMDER BLDG 1389, NAVSURFWARCENDIV NSDSA, 4363 MISSILE WAY, PORT HUENEME, CA 93043-4307**, or FAX 805-228-8714, or E-mail TMDER.NSWCPHD.FCT@Navy.MIL

FOLD HERE AND TAPE SECURELY
PLEASE DO NOT STAPLE

INCLUDE COMPLETE ADDRESS

**USE PROPER
POSTAGE**

FOR OFFICE USE ONLY

COMMANDER
CODE 310 BLDG 1389
NAVSURFWARCENDIV NSDSA
4363 MISSILE WAY
PORT HUENEME, CA 93043-4307

FOLD HERE AND TAPE SECURELY
PLEASE DO NOT STAPLE